



ALAMO  
COLLEGES  
DISTRICT

PURCHASE OF CONSTRUCTION SERVICES  
FOR RENOVATIONS TO THE EASTSIDE EDUCATION &  
TRAINING CENTER (EETC) FOR ALAMO COLLEGES  
DISTRICT

REQUEST FOR COMPETITIVE SEALED PROPOSAL  
CSP NO. 21C-001  
EDA Award No. 08-01-05138  
RELEASE DATE: October 16, 2020

Bids must be submitted to:  
Alamo Colleges District  
Purchasing and Contract Administration Department  
See addresses in "Instruction to Offerors"

Pre-Proposal Conference: November 5, 2020, 9:00 a.m.

Proposal Deadline: November 19, 2020, 2:00 p.m.

## TABLE OF CONTENTS

PROJECT NAME: Purchase of Construction Services for the Renovations to the Eastside Education & Training Center (EETC) for Alamo Colleges District

CSP NUMBER: 21C-001

LOCATION OF WORK: 4551 Dietrich Road, San Antonio, TX 78219 - 2839

## ALAMO COLLEGES

	<u># of Pages</u>
Title Page	1
Table of Contents	1
<u>DOCUMENT</u>	<u># of Pages</u>
Section	
1 Key Dates and Information	1
2 Background	4
3 Instruction to Offerors	17
4 Contractor's Organizational/Operational Statement	5
5 Proposal Form (includes Appendix A, B, C-EEOC & SMWVBE Guidelines, D-CIQ, E-Payment Bond, F-Performance Bond, G-Anti-Lobbying Certification Form, and H-Disclosure of Lobbying Activities)	21
6 Construction Agreement (includes Exhibit A1 to A6 and Exhibit B)	59
7 General Conditions of the Contract for Construction - AIA Document A201 - 2007	42

Project Manual (Garza/Bomberger & Associates, 760 Pages)

Drawings (Garza/Bomberger & Associates, 34 Pages, 30" x 42")

## SECTION 1: KEY DATES AND INFORMATION

- CSP NAME:** Competitive Sealed Proposal (CSP) for Purchase of Construction Services for the Renovations to the Eastside Education & Training Center (EETC) for Alamo Colleges District
- PRE-PROPOSAL MEETING:** A Pre-Proposal meeting is scheduled on November 5, 2020. The meeting will begin at 9:00 a.m. at 4551 Dietrich Road, San Antonio, TX 78219-2839. The meeting will be followed by a tour of the project site. The pre-proposal meeting is not mandatory; however, attendance is strongly encouraged to allow Offerors the opportunity to ask questions of the Architects and/or Engineers regarding the project.
- CLOSURE:** The Alamo Colleges District administrative offices and campuses are presently closed due to a declared state of emergency. During this time, we will respond to emails and to phone call messages only to [kgottfried@alamo.edu](mailto:kgottfried@alamo.edu) or (210) 485-0122. We will respond to United States mail or other deliveries to our office address only on a much-delayed basis received until we resume normal operations when the declared state of emergency is lifted.
- SUBMITTAL DEADLINE:** November 19, 2020, prior to 2:00 pm CT.
- DELIVERY LOCATION:** Alamo Colleges District  
Purchasing and Contract Administration  
Re: Purchase of Construction Services for the Renovations to the Eastside Education & Training Center (EETC) for Alamo Colleges District  
CSP #21C-001  
Reception Desk  
2222 N. Alamo St  
San Antonio, TX 78215
- CONTRACT TERM:** This is a one-time purchase.
- NOTICE:** All questions related to this CSP are to be directed to Karen Gottfried, Assistant Director of Purchasing, via email to: [kgottfried@alamo.edu](mailto:kgottfried@alamo.edu) with a copy to [dst-purchasing@alamo.edu](mailto:dst-purchasing@alamo.edu)

## SECTION 2: BACKGROUND

The Alamo Colleges District was established as a public community college through a public election in 1945. The District operates as a political subdivision under the laws of the State of Texas. A nine-member Board of Trustees is the governing body of the District. The Trustees are elected locally to six-year staggered terms by Bexar County voters. The Chancellor, the District's chief executive officer, guides and implements the program and policies of the Alamo Colleges District.

In Fall 2014, the Board of Trustees welcomed the inclusion of a Student Trustee member to serve as a non-voting student liaison to the Board of Trustees and Chancellor. The Student Trustee is selected from one of the five colleges by the elected Board members and serves for a one-year term.

The Alamo Colleges District, a comprehensive two-year system, is dedicated to providing quality education and workforce training to the people of Bexar and surrounding counties. The five colleges:

- San Antonio College (founded in 1925),
- St. Philip's College (founded in 1898),
- Palo Alto College (founded in 1983),
- Northeast Lakeview College (founded in 2007), and
- Northwest Vista College (founded in 1995)

support the education and lifelong learning needs of a multicultural community by providing associates degrees, certificates, pre-majors/transfer programs, continuing education, and community services. The 300+ programs are arranged in six Institutes, known as the AlamoINSTITUTES, by career choices: Creative & Communication Arts, Business & Entrepreneurship, Health & Biosciences, Advanced Manufacturing & Logistics, Public Services and Science & Technology. The Institutes have clear roadmaps to guide each student efficiently and effectively from his/her point of entry to attainment of high-quality post-secondary credentials and/or a career.

Student enrollment for the Spring 2019 semester was over 58,000. Students are taught by highly qualified faculty with Master's and Doctorate degrees who are committed to creating a learning-centered environment. Student services include advising, counseling, learning resource centers, computer labs, tutoring, financial aid services, services for the disabled, developmental instruction, veteran's services, service learning and job placement. A certified advisor works closely with each student to ensure each course taken can be counted toward the student's goal, and that completion of degrees and/or certificates can be accomplished most effectively and efficiently.

The Alamo Colleges District is the third largest community college system in enrollment in Texas, includes four colleges designated as Hispanic-Serving Institutions and includes the nation's only institution designated as both a Historically Black College and a Hispanic-Serving Institution. A vibrant international program brings students and faculty from places such as Mexico, Brazil, India and China to San Antonio for advanced education, while affording local students and faculty the opportunity to travel to all regions of the world, preparing them to work in an increasingly global economy.

### **Economic Conditions and Outlook**

The Alamo Colleges District operates in the strong economic area of San Antonio, Bexar County and surrounding counties. San Antonio is the nation's seventh-largest city with a population over 1.5 million and is projected to add 1.1 million new residents by 2040. San Antonio has a dynamic economy rapidly expanding from traditional military and service sectors into telecommunications, biomedical science, information



technology, data security and advanced manufacturing. The Alamo Colleges District has been an integral part of the Greater San Antonio community for more than 100 years, contributing significantly to the economic and social well-being of those who share this community with the District. Due to the quality of its workforce training and the success of its graduates, approximately 51% of students enrolled in post-secondary education in San Antonio attend one of the Alamo Colleges.

The three primary revenue streams to the Alamo Colleges District, other than federal grants used for scholarships, are ad valorem taxes, state appropriations, and tuition and fees.

- The trend of rising ad valorem tax revenues continued as revenues from ad valorem taxes increased by 7.0% in 2019 as net assessed property values of the District increased from approximately \$151.8 billion in 2018 to \$162.5 billion in 2019, providing funding for facilities' repairs and maintenance. The pattern of predictable and increasing property values and ad valorem tax collections relieves pressure to increase the tax rate for the District's constituents. There was no increase in the District's tax rate for fiscal year 2019.
- State appropriations, which are critical to keeping student tuition rates low, decreased in 2019 but are expected to increase in 2020 due to actions by the 86<sup>th</sup> Texas Legislature. State appropriations are distributed based on a cost-based formula for student contact hour reimbursement, core operations funding and student success outcomes. For fiscal year 2019, the State only provided 24% of instructional costs, down from 75% in fiscal years 2008-2009 and provided no funding for growth.
- Tuition and fee rates increased \$13 per semester credit hour, effective Spring 2019. This was the first rate increase since Spring 2016 and only the second increase since 2011. The student activity fee increased from \$1 per credit hour to \$3 per credit hour in Fall 2018. Student activity fees are used to support various student initiatives including leadership, clubs, organizations, sports, fitness and other events.

### **Strategic and Long-Term Financial Planning**

The Board approves a multi-year strategic plan that is reviewed and re-affirmed annually and involves all levels of the organization. Key performance indicators based on state and national peer institutions and annual performance targets are defined. An integrated planning model is used to strengthen the connection between the strategic plan, related action plans and the budget, which is approved annually by the Board of Trustees.

The budget is developed with broad-based staff involvement and is guided by budgetary, debt and financial policies approved by the Board. The budget includes a multi-year financial plan, which incorporates proposed increases for capital budgets, preventive maintenance and student success initiatives.

## Major Initiatives



The District and its partners are committed to ending poverty, enhancing economic and social mobility and meeting workforce demands in our city by joining forces to help more students complete college and obtain the necessary skills to hold high-wage, high-demand jobs. The AlamoPROMISE program, which will be available to high school seniors graduating in 2020, ensures that tuition and mandatory fees are covered for students who graduate from participating high schools. Over 5,000 high school seniors have already completed a “Save Your Seat” pledge, and enrollments at the Alamo Colleges District are expected to achieve double-digit growth within the first five years of the program. As a last-dollar funding source,

AlamoPROMISE covers the gap between financial aid and the cost of tuition for up to three years. The AlamoPROMISE eliminates financial barriers to higher education, making a college degree a reality.

The Alamo Colleges District continues to make significant progress on achieving greater student success, with a record 12,759 degrees and certificates awarded to students in fiscal year 2017, eclipsing the previous record of 12,009 awarded in the previous fiscal year. This achievement represents a tremendous 244% increase in degrees and certificates awarded between fiscal years 2006 and 2017, the largest increase among community colleges in Texas, and positions the Alamo Colleges District as the largest producer of degrees and certificates among all community colleges in the state of Texas. This improvement is directly related to two major initiatives implemented by the District. First, the *Four Disciplines of Execution* (4DX) provides a simple, repeatable set of practices for organizations and individuals to focus on what is important, to execute strategic priorities and to achieve superb results. Second, MyMap (My Monitoring Academic Progress) proactively engages students with deliberate activities at designated touch-points to ensure a consistent experience as they connect, enter, progress and complete their college goal.

## Awards and Acknowledgments

The Alamo Colleges District continues to be recognized both locally and nationally as a leader in higher education. On November 15, 2018, U.S. Commerce Secretary Wilbur Ross named the Alamo Colleges District a 2018 recipient of the Malcolm Baldrige National Quality Award (MBNQA), marking a significant milestone in the District’s ongoing journey to achieve the highest level of student success and performance excellence. A Presidential award, the Baldrige Award is the highest level of national recognition that a U.S. organization can receive for performance excellence in innovation, efficiency, and leadership. The Alamo Colleges District is the first community college system to achieve this level of recognition in the history of the program.





The Alamo Colleges District continues to be recognized both locally and nationally as a leader in higher education. The Alamo Colleges District is one of only two community colleges in the nation to receive the 2020 Leah Meyer Austin Award from Achieving the Dream (ATD). This national recognition is given annually to a college or colleges in the ATD network that show measurable improvement in student outcomes driven by top-to-bottom cultural change in the institution. Palo Alto College was also named as a Rising Star by ATD in 2019. All four of the accredited colleges in the Alamo Colleges District have been named to the Aspen Institute's list of 150 community colleges in the U.S. and Palo Alto College was one of three selected as a top-10 college that is now eligible to compete for the 2021, Aspen Prize for Community College Excellence. This is the first time nationally that four colleges from the same community college system have been nominated in the same year. The Aspen Prize is the nation's signature recognition of high achievement and performance for America's community colleges. The four colleges from the Alamo Colleges District were selected from a pool of nearly 1,000 public two-year colleges nationwide to compete for the \$1 million Aspen Prize in the categories of student learning, certificate and degree completion, employment and earnings and high levels of access and success for minority and low-income students.



The Alamo Colleges District has also earned numerous awards in the areas of procurement and finance. For the eighth consecutive year, the District was awarded the National Achievement of Excellence in Procurement Award from the National Procurement Institute. In addition, the Alamo Colleges District is one of four community colleges in Texas awarded the Certificate of Distinction by the Government Treasurers' Organization of Texas (GTOT) for its investment policy.

The Government Finance Officers Association (GFOA) awarded a Certificate of Achievement for Excellence in Financial Reporting to the Alamo Colleges District for its comprehensive annual financial report for the fiscal year ended August 31, 2018. This was the tenth consecutive year the District has achieved this prestigious award. In order to be awarded a Certificate of Achievement, a government must publish an easily readable and efficiently organized comprehensive annual financial report. The report must satisfy both generally accepted accounting principles and applicable legal requirements. A Certificate of Achievement is valid for a period of one year. We believe that our current comprehensive annual financial report continues to meet the Certificate of Achievement Program's requirements, and we are submitting it to the GFOA to determine its eligibility for another certificate.

Offerors can visit Alamo Colleges District' website at <https://www.alamo.edu/> to learn about Alamo Colleges.

## SECTION 3: INSTRUCTIONS TO OFFERORS

This Section Includes:

- A. Competitive Sealed Proposal Submission
- B. Budget and Intent
- C. Contract Time
- D. Definitions
- E. Contract Documents Identification
- F. Availability of Documents
- G. Examination of Documents
- H. Inquiries and Addenda
- I. Product Substitutions
- J. Pre-Proposal Conference
- K. Offeror Background
- L. Submission Procedure
- M. Award or Proposal Ineligibility
- N. Performance Assurance
- O. Additional Proposal Information
- P. Proposal Evaluation Criteria
- Q. Proposal Deadline
- R. Duration of Offer
- S. Acceptance of Offer
- T. Family Code Certification
- U. Franchise Tax Delinquency
- V. Release of Information
- W. Reimbursement
- X. Notification of Criminal History of Contractor
- Y. Texas Resident Information
- Z. Disclosure of Interest
- AA. Environmental Considerations
- BB. Continuous Improvements
- CC. Fair Labor Standards Act
- DD. HB 1295
- EE. Mission, Vision, and Values
- FF. Israel Boycott
- GG. Anti-Lobbying Certification
- HH. EDA Grant Requirements for Contractor and Subcontractors

A. COMPETITIVE SEALED PROPOSAL SUBMISSION

1. Signed and sealed proposals shall be submitted prior to 2:00 pm. Central Time (CT) on November 19, 2020. Offeror must provide one (1) original, (6) six bound copies, and one (1) electronic copy on flash/thumb drive (preferred format for electronic copy is Word or PDF), and delivered to:

Alamo Colleges District  
 Purchasing and Contract Administration  
 Re: Purchase of Construction Services for the Renovations to the Eastside Education & Training Center (EETC) for Alamo Colleges District  
 CSP # 21C-001  
 Reception Desk  
 2222 N. Alamo St.  
 San Antonio, TX 78215



2. Amendments to submitted proposals will be permitted when received in writing prior to proposal opening and when endorsed by the same party or parties who signed and sealed the proposal.
3. Offerors may withdraw their proposal by written request at any time before the proposal deadline.

**B. BUDGET AND INTENT**

1. The maximum estimated budget for the base proposal for the project: \$1,500,000.00.
2. The intent of this request for competitive sealed proposals is to obtain offers for the Purchase of Construction Services for the Renovations to the Eastside Education & Training Center (EETC) for Alamo Colleges District in accordance with the Contract Documents.
3. Additional work requiring an approved change order should not be commenced until written authorization to proceed has been received from the Alamo Colleges District. Work completed without such authorization, will not be recognized or paid by Alamo Colleges District.
4. In the event of a conflict between the front-end documents (Instructions to Offerors, and General Conditions) and the technical specifications/drawings, the front-end documents will prevail. Further, in the event of a conflict between the technical specifications and the drawings, the specifications shall prevail. In all instances where discrepancies exist between the requirements of the individual sections of the whole documents, the most stringent requirement shall apply.
5. The work of this project shall comply with all applicable federal, state, and local laws, codes, regulations and ordinances.

**C. CONTRACT TIME**

1. Offeror agrees to substantially complete the work covered by this proposal; within 180 calendar days after notice to proceed.
2. Generally, the work shall be scheduled during weekdays, between the hours of 8:00 a.m. and 5:00 p.m. Contractor will be allowed to work in the evenings, holidays and/or weekends when given written approval from the Alamo Colleges District Facilities Operations and Construction Management Department. The scheduled Alamo Colleges District holidays are as follows:

Labor Day	Sept. 2, 2020
Thanksgiving Break	Nov. 28 to Dec. 1, 2020
Winter Break	Dec. 21, 2020 to Jan. 1, 2021
Martin Luther King Jr. Day	Jan. 18, 2021
Spring Break	March 15, 2021 to March 21, 2021
Easter Holiday	April 2, 2021 to April 4, 2021
Fiesta Holiday	April 23, 2021
Independence Day	July 5, 2021

Additionally, the Contractor shall schedule his work operations to meet Owner occupancy requirements during the contract period.

3. The Alamo Colleges District requires the work to be completed as quickly as possible. Consideration will be given to estimated time of completion when evaluating submitted

proposals.

4. The official date of substantial completion shall be determined by the design team and the Owner in accordance with the contract documents.

If the contractor fails to substantially complete the work by the dates established in the contract documents for substantial completion, liquidated damages will be assessed, not as a penalty, rather as a reasonable forecast of just compensation for damages. An amount will be deducted from the money due or to become due to the contractor as follows:

Liquidated damages – Two Hundred Fifty Dollars (\$250.00) per calendar day

#### D. DEFINITIONS

1. Proposal Documents: Contract Documents supplemented with Instructions to Offerors, Information Available to Offerors, Proposal Form and Appendices, and bid securities, identified.
2. Contract Documents: Defined in Section 6
3. The term "Contract" means the construction contract and includes the Contract Documents.
4. Proposal: Executed Proposal Form and required attachments, together with Proposal Guaranty submitted in accordance with these Instructions to Offerors.
4. Proposal Price: Monetary sum identified by the Offeror in the Proposal Form.
5. Any use of the terms "Bid" or "Bidding" contained in any of the Proposal or Contract Documents, and referring to the submission of a price or proposal by the Offeror for the intent of securing an award of the Contract, shall be understood to refer to the submission of a Competitive Sealed Proposal as set forth herein. Any use of the term "Bidder" contained in the Proposal or Contract Documents shall be understood to refer to the Offeror making the proposal.
6. Days: The term "Days" shall be construed to mean "Calendar days", unless otherwise indicated.
7. The terms "Alamo Colleges," "Alamo Colleges District", "Alamo Community College District," "the District", "Owner", or "ACCD" shall have the same meaning.
8. Proposal Guaranty: A proposal (Bid Bond) showing Alamo Colleges District as the obligee in the amount of 5% of the Proposal Price must accompany the Proposal. If alternates are requested, then the bond must be in the amount of 5% of the highest Proposal Price considering the Base Proposal and alternates. The Proposal Guaranty secures the obligation of the selected Offeror to execute the Contract and provide required payment and performance bonds and insurance within the time period require.

#### E. CONTRACT DOCUMENTS IDENTIFICATION

The Contract Documents are identified as the Purchase of Construction Services for the Renovations to the Eastside Education & Training Center (EETC) for Alamo Colleges District, CSP No. 21C-001, as prepared by Garza/Bomberger & Associates and identified in the Project Manual.

F. AVAILABILITY OF DOCUMENTS

1. Proposal Documents may be obtained beginning October 16, 2020, after 10:00 a.m. from the Alamo Colleges District Purchasing and Contract Administration Department website at <http://www.alamo.edu/district/purchasing/bids/>.
2. No paper documents will be available.

G. EXAMINATION OF DOCUMENTS

1. Upon receipt of Proposal Documents verify documents are complete. Notify Alamo Colleges District Purchasing and Contract Administration Department if documents are incomplete.
2. Immediately notify Karen Gottfried, 210-485-0122 or email at [kgottfried@alamo.edu](mailto:kgottfried@alamo.edu) upon finding discrepancies or omissions in the Proposal Documents.
3. Offerors are required to thoroughly familiarize themselves with all of the provisions of the Instructions, Conditions, and Requirements of the Contract, the Bonds, the Drawings, and Specifications.

H. INQUIRIES AND ADDENDA

1. All questions/inquiries concerning published construction related projects are to be directed to the Alamo Colleges District Purchasing and Contract Administration Department. Questions/Inquiries must be submitted, in writing, to Karen Gottfried at [kgottfried@alamo.edu](mailto:kgottfried@alamo.edu). Alamo Colleges District is not responsible for misdirected or undelivered submissions.

District policy C.2.3.4 states that no College district Board member or employee other than authorized Purchasing and Contract Administration Department personnel shall communicate with potential contractors/consultants (including professional designers, project management professionals and the potential contractors'/consultants' employees, subcontractors, officers or agents) who are interested in, or might reasonably become interested in, any particular construction-related procurement opportunity from the date of publication until the contract is executed. If Board members or non-authorized employees are contacted during this time by any potential contractors/consultants described above, they shall inform the potential contractor/consultant that such communication is prohibited, direct them to the Purchasing and Contract Administration department, and immediately report the contact to the Legal Affairs department.

Offerors who violate this policy may be subject to a range of sanctions including disqualification from competition for the procurement opportunity and/or other future procurement opportunities after Board of Trustees review. Employees who violate this policy may be subject to disciplinary action, including termination after review by the Chancellor.

Verbal responses to any question are not binding on any party. Responses to questions which are to be incorporated into specifications/drawings will be issued by formal written addendum.

2. If any person contemplating submitting a proposal for this contract is in doubt as to the true meaning of the Specifications, or other CSP documents, or any part thereof, they may submit to Karen Gottfried, the designated point of contact for the Purchasing and Contract Administration Department, on or before seven (7) calendar days prior to the schedule deadline for receipt of proposals, a request for clarification.
3. All such requests for information shall be made in writing and the person submitting the request will be responsible for its prompt delivery. Any interpretation of the proposal, if made, will be

made only by Addendum duly issued. A copy of such addendum will be posted on Alamo Colleges District website (<http://www.alamo.edu/district/purchasing/bids/>) under the referenced CSP number for the project. An e-mailed notice will be sent to known potential Offerors and become part of the Contract Documents. The Alamo Colleges District is not responsible for any other explanation or interpretation of the proposed offer made or given prior to the award of the Contract. Offerors are to include resultant costs in the Proposal Price. Offeror shall acknowledge receipt of addenda in the spaces provided on the Proposal form.

#### I. PRODUCT SUBSTITUTIONS

1. Where Proposal Documents stipulate particular Products, substitution requests will be considered by the Alamo Colleges District Purchasing and Contract Administration Department up to the time for receipt of Proposals. Alamo Colleges District will make final determination of equivalency of the proposed substitution.
2. To the extent that specific manufacturer's name(s), model numbers, and stated specifications were derived from technical literature on the equipment and/or supplies and materials stated as desired, none of these should be construed as restrictive or limiting. The intent and purpose are to provide prospective Offerors with frames or reference regarding minimum requirements for each unit. Whenever an article of material is described by using the term or equal if not inserted shall be implied. The specified item shall be understood as indicating the type, function, minimum standard of design, efficiency, and quality desired and shall not be construed as to exclude other manufactured products of comparable quality, design, and efficiency. The use of an or equal item shall be subject to the following provisions: Full and complete catalog illustrations, manufacturer's specifications and descriptive, technical data defining in detail the equipment or product proposed. Please submit all requests for substitutions and approved equals to Karen Gottfried, in the Purchasing and Contract Administration Department.
3. THE REQUIREMENTS OF THE TWO PRECEDING PARAGRAPHS TAKE PRECEDENCE OVER ANY SUBSTITUTION REQUIREMENTS IN ANY SUBSEQUENT PARAGRAPHS, DIVISIONS, SECTIONS, OR DRAWINGS.

#### J. PRE-PROPOSAL CONFERENCE

1. A Pre-Proposal meeting is scheduled on November 5, 2020. The meeting will begin at 9:00 a.m. at 4551 Dietrich Road, San Antonio, TX 78219-2839. The meeting will be followed by a tour of the project site. The pre-proposal meeting is not mandatory; however, attendance is strongly encouraged to allow Offerors the opportunity to ask questions of the Architects and/or Engineers regarding the project.
2. Information relevant to Proposal Documents will be issued by Addendum.

#### K. OFFEROR BACKGROUND

To demonstrate qualification and competency for performing the Work of this Contract, Offerors shall submit written evidence of financial position, previous experience, current commitments, three (3) current references and license to perform work in the State of Texas, Bexar County, City of San Antonio.

#### L. SUBMISSION PROCEDURE

1. Submit one (1) original, six (6) bound copies and one (1) electronic copy on flash/thumb drive (preferred format for electronic copy is word or PDF), of the Proposal on the forms provided, signed and sealed, clearly identified as follows:

Alamo Colleges District  
Purchasing and Contract Administration  
Re: Purchase of Construction Services for the Renovations to the Eastside Education  
& Training Center (EETC) for Alamo Colleges District  
CSP # 21C-001  
Reception Desk  
2222 N. Alamo  
San Antonio, Texas 78215

2. Proposal received will be publicly acknowledged in the Staff Conference Room, Room 100, 1<sup>st</sup> floor, West Wing, which is directly behind the Reception Desk. A proposal received after the proposal deadline will be rejected and returned unopened. This is a Stipulated Sum Contract, and the stipulated sum proposal prices shall be inserted on the proposal sheet in words and figures. Conditional or unbalanced proposals will not be considered.
3. Proposals submitted by fax or by email will not be accepted.
4. Upon submission of a proposal, you agree to the following:

The Purchasing & Contract Administration recommendation and summary analysis will be uploaded to the applicable Alamo Colleges District Board of Trustees Committee agenda and will be viewable by the public on the Friday prior to the Tuesday Committee meeting where the contract award will be considered. Alamo Colleges District will use best efforts to notify Offerors by email shortly before the availability date for their proposals.

Alamo Colleges District's competitive response procedures are largely mandated by statute and do not permit the renegotiation of proposals after the submission deadline has passed. However, should you believe that Alamo Colleges District has made a calculation error regarding your proposal after reviewing the limited web-available summary analysis; its Purchasing & Contract Administration Department offers an opportunity for bidders/proposers not recommended for contract award to submit comments or engage in discussion concerning the proposed contract award promptly after the contract award recommendation is made public. Written comments may be submitted, or a meeting can be scheduled at your request. Consent to Alamo Colleges District's recording of any verbal interview, at its discretion, is a condition of any interview. This opportunity will be subject to any additional requirements that may appear in any notice that you may receive from the Purchasing and Contract Administration Department in order to be considered. Efforts to contact individual Trustees or Alamo Colleges District's employees other than those in the Purchasing & Contract Administration Department regarding such matters are prohibited.

M. AWARD OR PROPOSAL INELIGIBILITY

1. Proposals that contain irregularities of any kind may be declared unacceptable at Alamo College's discretion.
2. An award cannot be made to a party listed on the governmentwide exclusions in the System for Award Management (SAM), in accordance with the OMB guidelines at 2 CFR 180 that implement Executive Orders 12549 (3 CFR part 1986 Comp., p. 189) and 12689 (3 CFR part 1989 Comp., p. 235), "Debarment and Suspension." SAM Exclusions contains the names of parties debarred, suspended, or otherwise excluded by agencies, as well as parties declared ineligible under statutory or regulatory authority other than Executive Order 12549.

**N. PERFORMANCE ASSURANCE**

1. Payment Bonds meeting the requirements of 3. below shall be delivered to the Alamo Colleges District Purchasing and Contract Administration Office prior to execution of the Contract, provided the contract sum is \$25,000 or greater. Performance Bonds shall be delivered to the Alamo Colleges District Purchasing and Contract Administration Office prior to execution of the Contract, provided the contract sum is \$100,000 or greater. Such bonds are to be provided at no additional cost to the Alamo Colleges District.
2. Performance and Payment Bonds must be in conformance with all requirements of Texas State Law. Such bonds must be issued by sureties duly authorized by the State of Texas. Such bonds must be in compliance with Section 2253 of the Texas Government Code and all other State laws. Additionally, sureties issuing bonds in an amount of \$100,000 or greater must be listed as an approved surety in the U.S. Department of Treasury, Department Circular 570, most recent revision.
3. If the contract sum is \$25,000 or greater, the successful Offeror will be required as a condition precedent to the award of the Contract, to provide a fully executed Payment Bond in the form attached as Appendix E to these Instructions and as required by Section 2253 of the Texas Government Code in the amount equal to One Hundred Percent (100%) of the total Contract Amount.
4. If the contract sum is \$100,000 or greater, the successful Offeror will be required, as a condition precedent to the award of the Contract, to provide a fully executed Performance Bond attached as Appendix F to these instructions and as required by Section 2253 of the Texas Government Code in an amount equal to One Hundred Percent (100%) of the total Contract Amount .

**O. ADDITIONAL PROPOSAL INFORMATION**

1. The cost of City or State sales tax shall not be included in the base proposal, any alternate or required unit prices for this project. The Alamo Colleges District qualifies for exemption of the Texas Limited Sales, Excise and Use Taxes.
2. Offerors must state on the proposal form whether they owe State of Texas franchise taxes.
3. The Contractor affirms that he has not given, offered to give does not intend to give at any time hereafter any economic opportunity, contribution, future employment, gift, loan, gratuity, special discount, trip, favor, free lunch, or service to a public servant or elected official in connection with this contract.
4. The Alamo Colleges District Facilities Project Manager is one or more individuals designated by the Facilities Operations and Construction Management Department to monitor the performance of the work.
5. If asbestos or any other hazardous materials are encountered during the work, report the discovery to the Alamo Colleges District Facilities Project Manager immediately by telephone, followed by a written notice. All work in the suspected areas shall be stopped until areas are inspected and removal of the hazardous materials is completed. Hazardous materials will be removed and monitored by a separate Contractor arranged by the Alamo Colleges District.
6. This Project requires the Contractor and each subcontractor to maintain Worker's Compensation Insurance coverage for their respective employees. Prior to award, the recommended Contractor must provide an original certificate of insurance for worker's compensation as described in Section 6, Paragraph 11 of the CSP Documents.



7. Included in their Proposal all Offerors shall furnish Alamo Colleges District with a statement from their insurers that if awarded Alamo Colleges District will be provided with original certificates evidencing that the Offeror has all the required insurance types and levels as described in Section 6, Paragraph 11 of the CSP Documents, none of which shall be cancelled, altered or renewed until after thirty (30) days advance written notice received by Alamo Colleges District Director of Purchasing and Contract Administration.
8. An Offeror is required by Chapter 176 of the Texas Local Government Code to complete a conflict of interest questionnaire and file it with the Alamo Colleges District if the Offeror (i) has an employment or other business relationship with an officer of Alamo Colleges District, or a family member of an officer, or (ii) has given an officer of Alamo Colleges District or family member one or more gifts with an aggregate value that requires reporting under the statute, or (iii) has a family relationship with an officer of Alamo Colleges. The definitions of officer and family member, the valuation for gifts, and the deadline for filing the questionnaire are set out in the statute. Each Offeror shall determine whether their current business or family relationship with an officer of the District or family member of an officer is subject to the reporting requirements of Local Government Code sections 176.001 and 176.006. Should the Offeror meet the stated requirements of these sections, Form CIQ included in Appendix D to these Instructions shall be completed and submitted with the proposal.
9. The Contractor and subcontractors shall comply with the requirements set out in Section HH of these Instructions, including the Davis-Bacon Act which requires the Contractor and subcontractors to pay all laborers, workmen, and mechanics employed in the construction thereof not less than the applicable prevailing wage rates issued by the U.S. Department of Labor. The current prevailing wage rates for the location of the Project are attached as Exhibit 1 to these Instructions and are prescribed in General Conditions of the Contract for Construction and Exhibit 1. Contractor is required to use Davis Bacon wage rates including weekly certified payrolls and to report this using the LCP Tracker Wage and Hour Compliance software. Alamo Colleges District will provide access to this software to Contractor and Contractor's subcontractors as described in Section 6, Paragraph 25 of the CSP Documents.
10. The Contract is subject to contract compliance tracking, and the Contractor and any subcontractors are required to provide any noted and/or requested contract compliance-related data electronically in the B2Gnow Supplier Diversity Management System. The Contractor and all subcontractors are responsible for responding by any noted response date or due date to any instructions or request for information, and to check the B2Gnow Supplier Diversity Management System on a regular basis to manage contact information and Contract records. The Contractor is responsible for ensuring all subcontractors have completed all requested items and that their contact information is accurate and up-to-date. Alamo Colleges District may require additional information related to the Contract to be provided electronically through the system at any time before, during, or after Contract award. Information related to Contractor access of the system will be provided to a designated point of contact with the Contractor upon award of the Contract. The B2Gnow Supplier Diversity Management System is web-based and can be accessed through an internet address which will be provided to the Contractor and Contractor's subcontractors.

P. PROPOSAL EVALUATION CRITERIA

1. Pursuant to Texas Government Code 2269, as amended, Alamo Colleges District shall evaluate and consider all proposals based on a combination of price and other factors that Alamo Colleges District determines provides the best value to Alamo Colleges District, and may consider any of the following in determining to whom to award a Contract:
  - a. The price;
  - b. The Offeror's Experience and Reputation;

- c. The Offeror's Past Performance with Owners;
  - d. Subcontractors and Suppliers Support (including SMWVBE plan); and
  - e. Project Management Performance and Resources.
2. Within 45 days after the date of opening the proposals, the District and project architect/engineers must evaluate and rank each proposal submitted in relation to the published project budget and selection criteria.

Each proposal submitted must include all documentation, certifications and signatures. Incomplete proposals may be disqualified and not evaluated for award. The Alamo Colleges District reserves the right to accept or reject any or all offers and to waive minor irregularities in any proposal submitted.

Five broad selection criteria will be used to evaluate proposals as follows. The maximum amount of points available for each criteria section may vary depending on whether all components listed in each section are applicable to the current project or if additional components are added.

a. Price components (50 points): Alamo Colleges District may use various price analysis techniques and procedures to evaluate price. Normally, reasonableness of price is established through adequate price competition, but may also be separately assessed through mathematical price analysis techniques.

b. Offeror's Experience and Reputation (15 points): Number of years as a contractor with a specific experience in education facilities construction projects of the same or similar type and size of this project, including work performed in connection with a school facility which was occupied and in use during construction. The Owner will also consider the general reputation of the Offeror including, without limitation (1) knowledge, reliability, character, skill and stability; (2) record of timely completion of work, compliance with laws, and warranty service; (3) personnel and facilities for carrying out the Work; (4) safety record, safety procedures, and past claims or lawsuits; and (5) performance of satisfactory maintenance, repair, and service.

c. Offeror's Past Performance with Owners (5 points): Any past or ongoing projects with Alamo Colleges District and other owners will be considered in the evaluation process including (1) Ability of Offeror to remain on schedule; (2) Cooperation with Owner; (3) Proper and timely coordination of all trades and personnel in completing the project; (4) Number of major deficiencies on the substantial completion punch list; (5) Number of warranty item call backs and timely response; (6) Demonstration of excellence in workmanship; and (7) Safety record.

d. Subcontractors and Suppliers Support – Small, Minority, Veteran and/or Women Business Enterprise and Labor Surplus Area Firms (SMWVBE) (20 points): The Contractor will be required to comply with the Affirmative Steps set out below in paragraph 2 of Section HH (and to require its subcontractors to comply with such steps) to assure that minority businesses, women's business enterprises, and labor surplus area firms are used when possible. Alamo Colleges also encourages the use of veteran businesses. The Offeror must submit a plan with its Proposal in the form attached as Appendix C identifying the ways in which Contractor will perform the Affirmative Steps, including the manner in which Contractor will divide up work to encourage participation by these groups.

e. Project Management Performance and Resources - (10 points): The Offeror's: (1) evidence of sufficient resources necessary to manage, staff, and successfully perform the work contemplated; (2) financial resources; (3) performance time; and (4) compliance with administrative requirements. The Offeror shall be otherwise qualified and eligible to receive an award under applicable laws and regulations.

Each criterion will be rated at Maximum Score, In-between Score, Questionable (0 points), or Minimum Score (0 points) as defined below:

**MAXIMUM SCORE:** Contractor exceeds the generally accepted standards of industry and exceeds project specific requirements.

**SCORE BETWEEN MINIMUM AND MAXIMUM:** Use mathematical methods to assign proper score for each criteria.

**QUESTIONABLE:** (0 points) Contractor’s qualifications could not be adequately evaluated from information included with proposal. Additional information may be requested from offerors by a letter, email or through an interview to clarify criteria evaluated as Questionable. The offeror must respond within seventy-two (72) hours of verified receipt of a request of information. A non-timely response or a non-response will receive 0 points.

**MINIMUM SCORE:** (0 points) Contractor does not meet the generally accepted standards of industry or minimum required by state law. A non-response to a proposal item will receive 0 points.

Each of the five selection criteria may be further detailed by its components. A determination of an overall score of each selection criteria will be concluded based upon the rating of the components.

<b>Criteria Points</b>	<b>Section</b>	<b>Points</b>
Price components	P.2.a	50
Offeror’s Experience & Reputation	P.2.b	15
Offeror’s Past Performance with Owners	P.2.c	5
Subcontractors & Suppliers – Small, Minority, Veteran and/or Women Business Enterprise (SMWVBE)	P.2.d	20
Project Management Performance and Resources	P.2.e	10
<b>TOTAL</b>		<b>100</b>

**Q. PROPOSAL DEADLINE**

Proposals will be opened publicly with the name of the Offeror and proposal sum read aloud immediately after time for receipt of Proposals. Offerors and members of the public may be present.

**R. DURATION OF OFFER**

Proposals shall remain open to acceptance for a period of one hundred twenty (120) calendar days after final Proposal deadline.

**S. ACCEPTANCE OF OFFER**

1. The Alamo Colleges District reserves the right to accept or reject any or all offers.
2. The Board of Trustees of Alamo Colleges District will award the contract in the best interest of the District.
3. The successful Offeror will be required to enter into a contract with the Alamo Colleges District requiring full compliance and performance of the conditions of the Proposals, Drawings, and Specifications, within five (5) workdays after the award of Contract. The following is the anticipated schedule for this project:

A.	Advertise CSP	October 18, 2020 and October 25, 2020
B.	Pre-Proposal Meeting	November 5, 2020
C.	Proposal Deadline	November 19, 2020
D.	Anticipated Award of Contract	January 26, 2021
E.	Offeror submits acceptable 1295, bonds and insurance	Within 3 work days after notice of award
F.	Contract Signed	Within 3 work days after receipt of 1295, bonds and insurance
G.	Substantial Completion	February 1, 2021

Time is of the essence. Failure of Offeror to respond in a timely manner will jeopardize the number of remaining days allowed for substantial completion.

- 4. Unless otherwise specified, the Alamo Community College District is responsible for all plan review, building and trades permits, and inspection fees required by the City of San Antonio or any other jurisdiction having authority over this project.

T. FAMILY CODE CERTIFICATION

Prior to award of the contract, the Offeror to be recommended for award will be required to execute the following certification:

"Under Section 231.006, Family Code, the vendor or applicant certifies that the individual or business entity named in the contract, proposal or application is not ineligible to receive the specified grant, loan or payment and acknowledges that this contract may be terminated and payment may be withheld if this certification is inaccurate."

This certification is required for each person who is a sole proprietor, partner, shareholder, or owner with an ownership interest of at least 25 percent in the business entity submitting the proposal. The following information must be submitted for each person meeting the previously described conditions and executing the certification: name; social security number; signature; and date.

U. FRANCHISE TAX DELINQUENCY

If the Contractor is subject to the requirements of the Texas Franchise Tax and becomes delinquent in the payment of said tax, then payments to the Contractor due under this Agreement may be withheld until such tax delinquency is remedied.

V. RELEASE OF INFORMATION

The Alamo Colleges District is a governmental entity in the State of Texas. Documents submitted pursuant to this procurement solicitation become a government record. Access by the public to government records is governed by the Texas Public Information Act ("PIA"). Proprietary information, such as trade secrets and confidential commercial and financial information submitted in response to this procurement solicitation which Offeror (or any Offeror responding to this procurement solicitation) believes should be exempted from disclosure shall be specifically identified and marked as such. Blanket-type identification by designating a whole document or pages or sections as containing proprietary information, trade secrets or confidential commercial and financial information will not ensure confidentiality, especially if information is contained in the designated areas that clearly is not of a confidential nature. In the event a request is made for information designated as proprietary, Alamo Colleges District may determine in its sole discretion whether sufficient legal justification exists for withholding the information and whether an opinion should be requested from the Texas Attorney General. If an opinion is requested from the Texas Attorney General, Alamo Colleges District will

notify Offeror (or the particular Offeror affected) and Offeror has the responsibility, in accordance with PIA, to assert any arguments it may have in opposition to release of the information. In the event Offeror requests judicial intervention, the party so requesting shall indemnify Alamo Colleges District for its costs (including attorney's fees) associated with the judicial action. Under no circumstances will Alamo Colleges District be liable for any costs, damages, or claims of any nature, related to release or disclosure of any information contained in documents submitted pursuant to this procurement solicitation.

W. Alamo Colleges District will not reimburse Offerors responding to this CSP for any expenses incurred in preparing or presenting proposals. Alamo Colleges District reserves the right to retain all proposals and to use any ideas submitted in a proposal regardless of whether the proposal is selected.

X. NOTIFICATION OF CRIMINAL HISTORY OF CONTRACTOR.

A person or business entity that enters into a contract with Alamo Colleges District must give advance notice to the Alamo Colleges District if the person or an owner or operator of the business entity has been convicted of a felony. The notice must include a general description of the conduct resulting in the conviction of a felony.

Alamo Colleges District may terminate a contract with a person or business entity if the Alamo Colleges District determines that the person or business entity failed to give notice as required by the previous paragraph or misrepresented the conduct resulting in the conviction. The Alamo Colleges District must compensate the person or business entity for services performed before the termination of the contract. The criminal history notification requirement does not apply to a public held corporation.

Y. TEXAS RESIDENT INFORMATION

Under Chapter 2252, Subchapter A, of the Texas Government Code establishes certain requirements applicable to proposers who are not Texas residents. Under the statute, a "resident" Offeror is one whose principal place of business is in Texas, including one whose ultimate parent company or majority owner has its principal place of business in Texas. Section 44.031 (b) of the Texas Education Code establishes certain criteria that a community college in the State of Texas must consider when determining to whom to award an Agreement. Among the criteria for certain Agreements is whether the vendor or the vendor's ultimate parent or majority owner (i) has its principal place of business in Texas; or (ii) employs at least 500 people in Texas.

Z. DISCLOSURE OF INTEREST

All Offerors must disclose the name(s) of any of its employees, officers, directors, subcontractors, or agents who may also be a member of the Board of Trustees, or an employee or agent of the District. Further, all Offerors must disclose the name of any District employee, or Board of Trustees member, who has directly or indirectly, any financial interests in Offerors firm or any of its branches, submit this information on an attachment to the proposal which is to be titled "Disclosure of Interest" and included the person's name, position, and the extent of financial or other interest the person(s) has in Offeror's business affairs.

AA. The Alamo Colleges District makes environmental considerations with performance, availability, and costs of buying environmentally preferable goods and services. All products and services must meet or exceed the standards set by independent accredited organization in order to be deemed environmentally preferable.

BB. CONTINUOUS IMPROVEMENTS

Intentionally omitted.

CC. Contractor agrees to the following regarding any employees assigned to work at Alamo Colleges District' premises on a regular basis: Contractor agrees to comply with the record-keeping and all other requirements of applicable laws, including, without limitation, the Fair Labor Standards Act ("FLSA") and the Immigration Reform and Control Act of 1986. Contractor agrees to properly classify its workers for purposes of the FLSA and the Internal Revenue Code and timely pay wages and compensation for their services rendered. Contractor agrees to perform criminal background checks and to implement and enforce a written policy for a drug-free workplace providing for drug and alcohol testing prior to hiring and for reasonable cause during employment, complying with all applicable requirements, including obtaining the worker's authorization. Contractor represents and warrants that any worker it assigns to the Project shall have passed the criminal background check and any drug testing conducted. Contractor agrees to certify in writing at the request of Alamo Colleges District its compliance with any of its obligations in this Agreement.

DD. In accordance with HB 1295, Texas Government code 2252.908, the awarded contractor will be required to submit an electronic Disclosure of Interested Parties to Alamo Colleges District for any contract over \$1,000,000 or any contract that requires a vote by the Alamo Colleges District Board of Trustee, at the time of contract execution. The 1295 Certificate of Interested Parties Electronic Filing application website is: [https://www.ethics.state.tx.us/whatsnew/elf\\_info\\_form1295](https://www.ethics.state.tx.us/whatsnew/elf_info_form1295)

EE. MISSION, VISION, AND VALUES

We believe that economically, it makes good business sense and contributes to student success to be engaged in partnership between contractors, employees, educators, and the community to implement the Alamo Colleges District Mission, Vision, and Values. The Alamo Colleges District promotes collaboration by achieving consensus on the measures of student success and by stressing that student success is everyone's business. In 2014, the Alamo Colleges District adopted policy that includes our Vision, Mission, and Values: [Alamo Way](#)

In support of our policy, the purpose of this segment is to enhance recognition by contractors for our efforts. As a valued member in our procurement process, we ask that your company demonstrate their commitment to serving students by becoming actively engaged in recognizing the Alamo Colleges District Mission, Vision, and Values.

FF. ISRAEL BOYCOTT

Offeror hereby certifies, represents and warrants that neither Offeror nor any of its affiliates presently does, and during the term of the contract will any of them, boycott the State of Israel, by, without limitation, refusing to deal with, terminating business activities with, or otherwise taking any action that is intended to penalize, inflict economic harm on or limit commercial relations with the State of Israel, or with a person or entity doing business within the State of Israel or in any territory controlled by the State of Israel.

GG. ANTI-LOBBYING CERTIFICATION

No federal funds may be used to pay any person or organization for influencing or attempting to influence an officer or employee of any agency, a member of Congress, officer or employee of Congress, or an employee of a member of Congress in connection with obtaining any Federal contract, grant or any other award. The successful Offeror must sign an Anti-Lobbying Certification in the form attached as Appendix G to these Instructions and must require each subcontractor or supplier whose contract exceeds \$100,000 to sign a Certificate, copies of which must be provided to Alamo Colleges District.



## HH. EDA GRANT REQUIREMENTS FOR CONTRACTOR AND SUBCONTRACTORS

The Project is funded in whole or in part by a grant from the Economic Development Administration (EDA) of the U.S. Department of Commerce. The Contractor is required to comply with all of the following requirements, which are set out in the Contract, and where applicable, to require its subcontractors and their sub-subcontractors to comply with them.

It is the obligation of each Offeror to discuss the following requirements with the Offeror's legal counsel or other consultants so that the Offeror understands the requirements and obligations. The Alamo Colleges District cannot advise Offerors on the meaning or application of these Federal laws and regulations.

1. Equal Employment Opportunity Act. During the performance of this contract, the Contractor agrees as follows:

a. The contractor will not discriminate against any employee or applicant for employment because of race, color, religion, sex, sexual orientation, gender identity, or national origin. The contractor will take affirmative action to ensure that applicants are employed, and that employees are treated during employment without regard to their race, color, religion, sex, sexual orientation, gender identity, or national origin. Such action shall include, but not be limited to the following:

Employment, upgrading, demotion, or transfer; recruitment or recruitment advertising; layoff or termination; rates of pay or other forms of compensation; and selection for training, including apprenticeship. The contractor agrees to post in conspicuous places, available to employees and applicants for employment, notices to be provided setting forth the provisions of this nondiscrimination clause.

b. The contractor will, in all solicitations or advertisements for employees placed by or on behalf of the contractor, state that all qualified applicants will receive consideration for employment without regard to race, color, religion, sex, sexual orientation, gender identity, or national origin.

c. The contractor will not discharge or in any other manner discriminate against any employee or applicant for employment because such employee or applicant has inquired about, discussed, or disclosed the compensation of the employee or applicant or another employee or applicant. This provision shall not apply to instances in which an employee who has access to the compensation information of other employees or applicants as a part of such employee's essential job functions discloses the compensation of such other employees or applicants to individuals who do not otherwise have access to such information, unless such disclosure is in response to a formal complaint or charge, in furtherance of an investigation, proceeding, hearing, or action, including an investigation conducted by the employer, or is consistent with the contractor's legal duty to furnish information.

d. The contractor will send to each labor union or representative of workers with which he has a collective bargaining agreement or other contract or understanding, a notice to be provided advising the said labor union or workers' representatives of the contractor's commitments under this section, and shall post copies of the notice in conspicuous places available to employees and applicants for employment.

e. The contractor will comply with all provisions of Executive Order 11246 of September 24, 1965, and of the rules, regulations, and relevant orders of the Secretary of Labor.

- f. The contractor will furnish all information and reports required by Executive Order 11246 of September 24, 1965, and by rules, regulations, and orders of the Secretary of Labor, or pursuant thereto, and will permit access to his books, records, and accounts by the administering agency and the Secretary of Labor for purposes of investigation to ascertain compliance with such rules, regulations, and orders.
- g. In the event of the contractor's noncompliance with the nondiscrimination clauses of this contract or with any of the said rules, regulations, or orders, this contract may be canceled, terminated, or suspended in whole or in part and the contractor may be declared ineligible for further Government contracts or federally assisted construction contracts in accordance with procedures authorized in Executive Order 11246 of September 24, 1965, and such other sanctions may be imposed and remedies invoked as provided in Executive Order 11246 of September 24, 1965, or by rule, regulation, or order of the Secretary of Labor, or as otherwise provided by law.
- h. The contractor will include the portion of the sentence immediately preceding paragraph (1) and the provisions of paragraphs (1) through (8) in every subcontract or purchase order unless exempted by rules, regulations, or orders of the Secretary of Labor issued pursuant to section 204 of Executive Order 11246 of September 24, 1965, so that such provisions will be binding upon each subcontractor or vendor. The contractor will take such action with respect to any subcontract or purchase order as the EDA grant administrator may direct as a means of enforcing such provisions, including sanctions for noncompliance:

Provided, however, that in the event a contractor becomes involved in, or is threatened with, litigation with a subcontractor or vendor as a result of such direction by the grant administrator, the contractor may request the United States to enter into such litigation to protect the interests of the United States.

- 2. Affirmative Steps to Assure that Minority Businesses, Women's Business Enterprises, and Labor Surplus Area Firms are used.

The Contractor must take all necessary affirmative steps to assure that minority businesses, women's business enterprises, and labor surplus area firms are used when possible. Affirmative steps must include:

- a. Placing qualified small and minority businesses and women's business enterprises on solicitation lists;
- b. Assuring that small and minority businesses, and women's business enterprises are solicited whenever they are potential sources;
- c. Dividing total requirements, when economically feasible, into smaller tasks or quantities to permit maximum participation by small and minority businesses, and women's business enterprises;
- d. Establishing delivery schedules, where the requirement permits, which encourage participation by small and minority businesses, and women's business enterprises;
- e. Using the services and assistance, as appropriate, of such organizations as the Small Business Administration and the Minority Business Development Agency of the Department of Commerce; and
- f. Requiring Subcontracts to take the affirmative steps listed in paragraphs (a) through (e) of this section.

3. Davis-Bacon Act.

The Contractor and all subcontractors are required to comply with the Davis-Bacon Act (40 U.S.C. 3141-3144, and 3146-3148) as supplemented by Department of Labor regulations (29 CFR Part 5, "Labor Standards Provisions Applicable to Contracts Covering Federally Financed and Assisted Construction"), including, but not limited to the requirement to pay laborers and mechanics not less than the wage rates established by the U. S. Department of Labor for the County in which the Project is located, and to pay wages not less than once a week.

4. Copeland "Anti-Kickback" Act.

The Contractor and all subcontractors must comply with the Copeland "Anti-Kickback" Act (40 U.S.C. 3145), as supplemented by Department of Labor regulations (29 CFR Part 3, "Contractors and Subcontractors on Public Building or Public Work Financed in Whole or in Part by Loans or Grants from the United States"). The Contractor and each subcontractor is prohibited from inducing, by any means, any person employed in the construction, completion, or repair of the Project, to give up any part of the compensation to which he or she is otherwise entitled.

5. Contract Work Hours and Safety Standards Act (40 U.S.C. 3701-3708).

For Contracts that are greater than \$100,000, the Contractor and all subcontractors are required to comply with 40 U.S.C. 3702 and 3704, as supplemented by Department of Labor regulations (29 CFR Part 5). Under 40 U.S.C. 3702 of the Act, including the requirement to compute the wages of every mechanic and laborer on the basis of a standard work week of 40 hours. Work in excess of the standard work week is permissible provided that the worker is compensated at a rate of not less than one and a half times the basic rate of pay for all hours worked in excess of 40 hours in the work week. The requirements of 40 U.S.C. 3704 are applicable to construction work and provide that no laborer or mechanic must be required to work in surroundings or under working conditions which are unsanitary, hazardous or dangerous.

6. Rights to Inventions Made Under a Contract or Agreement.

If the Federal award meets the definition of "funding agreement" under 37 CFR §401.2 (a) and the Contractor or a subcontractor wishes to enter into a contract with a small business firm or nonprofit organization regarding the substitution of parties, assignment or performance of experimental, developmental, or research work under that "funding agreement," the Contractor or subcontractor must comply with the requirements of 37 CFR Part 401, "Rights to Inventions Made by Nonprofit Organizations and Small Business Firms Under Government Grants, Contracts and Cooperative Agreements," and any implementing regulations issued by the awarding agency.

7. Clean Air Act (42 U.S.C. 7401-7671q.) and the Federal Water Pollution Control Act (33 U.S.C. 1251-1387), as amended.

For contracts and subcontracts that are in excess of \$150,000, the Contractor and subcontractor must comply with all applicable standards, orders or regulations issued pursuant to the Clean Air Act (42 U.S.C. 7401-7671q) and the Federal Water Pollution Control Act as amended (33 U.S.C. 1251-1387). Violations must be reported to the Federal awarding agency and the Regional Office of the Environmental Protection Agency (EPA).

8. Debarment and Suspension (Executive Orders 12549 and 12689)

A contract award (see 2 CFR 180.220) must not be made to parties listed on the governmentwide exclusions in the System for Award Management (SAM), in accordance with the OMB guidelines at 2 CFR 180 that implement Executive Orders 12549 (3 CFR part 1986 Comp., p. 189) and

12689 (3 CFR part 1989 Comp., p. 235), "Debarment and Suspension." SAM Exclusions contains the names of parties debarred, suspended, or otherwise excluded by agencies, as well as parties declared ineligible under statutory or regulatory authority other than Executive Order 12549.

9. Byrd Anti-Lobbying Amendment (31 U.S.C. 1352)

The Contractor, and each subcontractor that applies or bids for a subcontract exceeding \$100,000, must file the required Anti-Lobbying certification. Each tier certifies to the tier above that it will not and has not used Federal appropriated funds to pay any person or organization for influencing or attempting to influence an officer or employee of any agency, a member of Congress, officer or employee of Congress, or an employee of a member of Congress in connection with obtaining any Federal contract, grant or any other award covered by 31 U.S.C. 1352. Each tier must also disclose any lobbying with non-Federal funds that takes place in connection with obtaining any Federal award. Such disclosures are forwarded from tier to tier up to the non-Federal award. The Contractor must obtain and forward the Certification to the Alamo Colleges District.

10. Procurement of Recovered Materials.

Contractor must comply with section 6002 of the Solid Waste Disposal Act, as amended by the Resource Conservation and Recovery Act. The requirements of Section 6002 include procuring only items designated in guidelines of the Environmental Protection Agency (EPA) at 40 CFR part 247 that contain the highest percentage of recovered materials practicable, consistent with maintaining a satisfactory level of competition, where the purchase price of the item exceeds \$10,000 or the value of the quantity acquired during the preceding fiscal year exceeded \$10,000; procuring solid waste management services in a manner that maximizes energy and resource recovery; and establishing an affirmative procurement program for procurement of recovered materials identified in the EPA guidelines.

SECTION 4 - CONTRACTOR'S ORGANIZATION/OPERATIONAL STATEMENT

This statement, fully executed, must accompany any proposal submitted to Alamo Colleges for Alamo Colleges to consider such proposal.

The undersigned certifies under oath that the information provided herein is true and sufficiently complete so as not to be misleading.

SUBMITTED BY:

NAME: \_\_\_\_\_ Corporation \_\_\_\_\_

ADDRESS: \_\_\_\_\_ Partnership \_\_\_\_\_

\_\_\_\_\_ Individual \_\_\_\_\_

PRINCIPAL OFFICE: \_\_\_\_\_ Joint Venture \_\_\_\_\_

PHONE: \_\_\_\_\_ Other \_\_\_\_\_

FAX: \_\_\_\_\_ EMAIL: \_\_\_\_\_

NAME OF PROJECT (IF APPLICABLE)

Purchase of Construction Services for the Renovations to the Eastside Education & Training Center (EETC) for Alamo Colleges District

TYPE OF WORK:

\_\_\_ General Building Construction

\_\_\_ Site-work

\_\_\_ HVAC

\_\_\_ Landscaping

\_\_\_ Electrical

\_\_\_ Irrigation

\_\_\_ Mechanical

\_\_\_ Plumbing

\_\_\_ Concrete

\_\_\_ Roofing

\_\_\_ Masonry

\_\_\_ Interior Finishes

\_\_\_ Other \_\_\_\_\_ (Please specify)

A. Organization

1. How long has your organization been in business as a Contractor? \_\_\_\_\_ Years

2. How many years has your organization been in business under its present business name? \_\_\_\_\_ Years

a. Under what other or former names has your organization operated?

\_\_\_\_\_

\_\_\_\_\_

3. If your organization is a corporation, answer the following:

- a. Date of incorporation: \_\_\_\_\_
- b. State of incorporation: \_\_\_\_\_
- c. President's name: \_\_\_\_\_
- d. Vice-President's name: \_\_\_\_\_
- e. Secretary's name: \_\_\_\_\_
- f. Treasurer's name: \_\_\_\_\_

4. If your organization is a partnership, answer the following:

- a. Date of organization: \_\_\_\_\_
- b. Type of Partnership (if applicable) \_\_\_\_\_
- c. Name(s) of general partner(s) \_\_\_\_\_

5. If your organization is individually owned, answer the following:

- a. Date of organization: \_\_\_\_\_
- b. Name of owner: \_\_\_\_\_

6. If the form of your organization is other than those listed above, describe it and name the principals:

\_\_\_\_\_  
\_\_\_\_\_

B. Licensing

2. List jurisdictions and trade categories in which your organization is legally qualified to do business, and indicate registration or license numbers, if applicable.

\_\_\_\_\_  
\_\_\_\_\_

2. List jurisdictions in which your organization's partnership or trade name is filed.

\_\_\_\_\_  
\_\_\_\_\_



C. Experience

1. List the categories of work that your organization normally performs with its own forces.  
 \_\_\_\_\_  
 \_\_\_\_\_
  
2. Claims and Suits. (If the answer to any of the questions below is yes, please attach details).
  - a. Has your organization ever failed to complete any work awarded to it?  
 YES       NO
  
  - b. Are there any judgments, claims, arbitration proceedings or suits pending or outstanding against your organization or its officers?  
 YES       NO
  
  - c. Has your organization filed any lawsuits or requested arbitration with regard to construction contracts within the last five years?  
 YES       NO
  
3. Within the last five years, has any officer or principal of your organization ever been an officer or principal of another organization when it failed to complete a construction contract? (If the answer is yes, please attach details).  
 YES       NO
  
4. On a separate sheet, list major projects your organization has in progress, giving the name of project, start date of the project, owner's contact person and phone number, architect, architect's contact person and phone number, contract amount, percent complete, and scheduled completion date.
  - a. State total worth of work in progress and under contract: \$ \_\_\_\_\_ .
  
5. On a separate sheet, list the major projects your organization has completed in the past five years, giving the name of project, owner, owner contact person and phone number, architect, architect's contact person and phone number, contract amount, dates of start and completion, method of project delivery, brief description of scope of work, status of occupancy of the facility during construction, and percentage of the cost of the work performed with your own forces.
  - a. State average annual dollar amount of construction work performed during the past five years: \_\_\_\_\_ .
  
6. On a separate sheet, list the construction experience and present commitments of the key individuals of your organization.
  
7. List individuals and attach detailed resumes of the positions indicated below who may be assigned for the entire duration of the Project and may not be replaced except as allowed in the Contract Documents or approved in writing by Owner:

Project Manager: \_\_\_\_\_

Assistant Project Manager: \_\_\_\_\_

Project Superintendent: \_\_\_\_\_

Assistant Project Superintendent: \_\_\_\_\_

8. Provide evidence in an attachment of sufficient resources necessary to manage staff and successfully perform the Work. Provide a profile in addition to the above information to assist the Owner in its evaluation. Include an organizational structure and indicate the number and qualifications of key personnel. Include a discussion of the methods, tools, or procedures used to schedule the Work and complete projects on time. Include evidence of ability to obtain bonding, insurance and the ability to cover operating costs.
9. Describe in an attachment the Offeror's system for the selection, award and management of subcontractors and suppliers. Include methods to encourage subcontractors to accelerate their work schedule.

D. References

1. Trade References:

Name	Address	Telephone
------	---------	-----------

Name	Address	Telephone
------	---------	-----------

Name	Address	Telephone
------	---------	-----------

2. Surety:

a. Name of bonding company: \_\_\_\_\_

b. Name, address, and phone number of agent:

Name	Address	Telephone
------	---------	-----------

3. Surety:

a. Name of bonding company: \_\_\_\_\_

b. Name, address, and phone number of agent:

---

E. Financing

1. Financial Statement. The Offeror must submit a current report of his financial condition sworn to before a Notary Public. Any offeror wishing to maintain confidentiality of financial information must include a written request for same with submission of the proposal.

For all business entities other than publicly held corporations, please provide the following:

Attach a financial statement, preferably audited, including your organization's latest balance and income statement showing current assets, net fixed assets, other assets, current liabilities and other liabilities. Clearly indicate name and address of firm preparing financial statement, and date thereof. If the financial statement is not for the identical organization named above, explain below the relationship and financial responsibility of the organization whose financial

statement is provided (parent, subsidiary, etc.)

\_\_\_\_\_  
\_\_\_\_\_

F. Award to Nonresident Offerors

- 1. Is your business organized under the laws of the State of Texas?  
 YES       NO
- 2. If no, what is your principal place of business?

\_\_\_\_\_

Proposals from nonresident contractors shall be evaluated according to  
TEX. GOV'T CODE Section 2252.002.

G. Signature

- 1. Dated at \_\_\_\_\_ this \_\_\_\_\_ day of \_\_\_\_\_, 2014

Name of Organization \_\_\_\_\_

By: \_\_\_\_\_

Printed Name: \_\_\_\_\_

Title: \_\_\_\_\_

\_\_\_\_\_, being duly sworn, deposes and says that the information  
provided herein is true and sufficiently complete so as not to be misleading.

Subscribed and sworn before me this \_\_\_\_\_ day of \_\_\_\_\_, 2014.

\_\_\_\_\_  
NOTARY PUBLIC, STATE OF TEXAS

My Commission Expires: \_\_\_\_\_

\_\_\_\_\_  
Typed or Printed Name of Notary

SECTION 5: PROPOSAL FORM

The undersigned Offeror, having examined the construction documents and the sites of the proposed work and being familiar with all of the conditions surrounding the construction of the proposed project, including the availability of materials and labor, hereby proposes to furnish all labor and materials for the Purchase of Construction Services for the Renovations to the Eastside Education & Training Center (EETC) for Alamo Colleges District, in strict accordance with requirements of Drawings and Specifications, and subsequent Addenda thereto issued before this date.

Submitted by: \_\_\_\_\_  
(Full Company Name)

Full address \_\_\_\_\_  
\_\_\_\_\_

Telephone: \_\_\_\_\_ fax: \_\_\_\_\_

Email Address: \_\_\_\_\_

1. A. BASE OFFER:

Having examined the Places of The Work and all matters referred to in the Instructions to Offerors, Proposal Documents and Contract Documents, for the above-mentioned project, we the undersigned, hereby offer to enter into a Contract to perform the Work for the Contract Sum of:

\$ \_\_\_\_\_ dollars (\$ \_\_\_\_\_ )

B. ALTERNATE BID NO. 1: Remove existing toilet and toilet accessories at single use toilet rooms indicated on Drawings: Work includes capping waste lines, removing existing floor tile and preparing walls and floor to receive new finishes. Base Bid – No work in these rooms.

\$ \_\_\_\_\_ dollars (\$ \_\_\_\_\_ )

C. ALTERNATE BID NO. 2: Replace doors 005 and 006 at IDF 101 and Admin. Office respectively. Finish door to match existing doors. Base Bid – Existing doors 005 and 006 to remain; refinish doors to match existing doors.

\$ \_\_\_\_\_ dollars (\$ \_\_\_\_\_ )

The Alamo Colleges will only allow for a maximum of 15% fixed mark-up percentage for change orders (includes all overhead and profit). If you propose to offer less than 15%, please indicate your percentage mark-up here, otherwise a 15% mark-up will be applied: \_\_\_\_\_%

2. ACCEPTANCE

This offer shall be open to acceptance for 120 calendar days from the proposal opening date. If this proposal is accepted by the Alamo Colleges within the time period stated above, we will:

- A. Execute the Agreement within five (5) working days of receipt of Notice of Award or as otherwise indicated in the Instructions to Offerors, Proposal Documents and Contract Documents.
- B. Furnish the required bonds within three (3) working days of receipt of Notice of Award or as otherwise indicated in the Instructions to Offerors, Proposal Documents and Contract Documents.
- C. Commence work within seven days after written Notice to Proceed or as otherwise indicated in the Instructions to Offerors, Proposal Documents and Contract Documents.

If the proposal is accepted within the time stated, and we fail to commence the Work or we fail to provide the required Bond(s), the security deposit shall be forfeited as damages to the Alamo Colleges by reason of our failure, limited in amount to the lesser of the face value of the security deposit or the difference between this proposal and the proposal upon which a Contract is signed.

3. CONTRACT TIME

- A. Offeror agrees to substantially complete the work covered by this bid within 180 calendar days after notice to proceed.
- B. The official date of substantial completion shall be determined by the design team and the Owner in accordance with the contract documents.

If the contractor fails to substantially complete the work by the dates established in the contract documents for substantial completion, liquidated damages will be assessed, not as a penalty, rather as a reasonable forecast of just compensation for damages. An amount will be deducted from the money due or to become due to the contractor as follows:

Liquidated Damages – Two Hundred Fifty Dollars (\$250.00) per calendar day

4. ADDENDA

The following Addenda have been received. The modifications to the Contract Documents noted therein have been considered and all costs thereto are included in the Proposal Sum.

Addendum # \_\_\_\_\_ Dated \_\_\_\_\_ Addendum # \_\_\_\_\_ Dated \_\_\_\_\_

Addendum # \_\_\_\_\_ Dated \_\_\_\_\_ Addendum # \_\_\_\_\_ Dated \_\_\_\_\_

5. APPENDICES

- Appendix A Competitive Sealed Proposal Checklist
- Appendix B Certification of Non-Collusion
- Appendix C EEOA Affirmative Steps for Use of Minority Business Enterprises, Women’s Business Enterprises and Labor Surplus Area Firms and Alamo Colleges District’s Guidelines on Utilization of Small, Minority, Women and/or Veteran Business Enterprise (SMWVBES)
- Appendix D Conflict of Interest Questionnaire
- Appendix E Payment Bond
- Appendix F Performance Bond
- Appendix G Anti-Lobby Certification

Appendix H Disclosure of Lobbying Activities

(APPENDIX A THRU H MUST BE SUBMITTED WITH PROPOSAL)

6. WAIVER OF CLAIM

By submitting a Proposal, each Offeror agrees to waive any claim it has or may have against the District, the Architect/Engineer, and their respective employees, arising out of or in connection with the administration, evaluation, or recommendation of any Proposal; waiver of any requirements under the Proposal Documents; or the Contract Documents; acceptance or rejection of any proposals; and award of the Contract.

7. PROPOSAL FORM CERTIFICATION/SIGNATURES

By execution and submission of this Proposal, the Offeror hereby represents and warrants to Owner as follows: the Offeror has read and understands the Proposal Documents and the Contract Documents and this Proposal is made in accordance with the Proposal Documents.

The Corporate Seal of

\_\_\_\_\_  
(Offeror - print the full name of your firm)

was hereunto affixed in the presence of:

\_\_\_\_\_  
(Authorized signing Officer)

\_\_\_\_\_  
(Title)

If the proposal is a joint venture or partnership, add additional forms of execution for each member of the joint venture in the appropriate form or forms as above.

\_\_\_\_\_  
Authorized Signature

\_\_\_\_\_  
Company Name

\_\_\_\_\_  
Date



APPENDIX A  
COMPETITIVE SEALED PROPOSAL CHECKLIST

- Y\_\_ N\_\_ 1. Is bid bond in the amount of 5% of the total proposal amount attached?
- Y\_\_ N\_\_ 2. Is statement from insurance company attached?
- Y\_\_ N\_\_ 3. Is Contractor's Organization/Operational Statement (Section 4, above) completed and attached?
- Y\_\_ N\_\_ 4. Was your firm represented at the pre-proposal conference?
- Y\_\_ N\_\_ 5. Did your firm inspect the job sites prior to submission of your proposal?
- Y\_\_ N\_\_ 6. Have all project specifications and proposal requirements been met?
- Y\_\_ N\_\_ 7. Is your proposal submitted in one original, six complete copies and one electronic copy in PDF format?
- Y\_\_ N\_\_ 8. Is your Letter and SMWVBE Subcontracting Plan included?

Please assist us in keeping your company information accurate and up to date by checking the appropriate blocks.

- A.  Dealer  Manufacturer  Jobber  Retailer  Factory Rep  
 Individual  Partnership  Incorporated  Publisher  Non-profit  
 Governmental Agency  Educational Institution  Professional Organization

- B.  Minority Owned Business, if so please state:  
 Black  Hispanic  Native American  Asian Pacific American  
 Small Business  Women-Owned

- C. Is your business considered historically socially/economically disadvantaged?  
 Yes  No  
 If so, is your business currently certified as such?  Yes  No  
 With whom? \_\_\_\_\_

- D. Do you currently owe State of Texas franchise taxes?  Yes  No

If the Contractor is subject to the requirements of the Texas Franchise Tax and becomes delinquent in the payment of said tax, then payments to the Contractor due under this Agreement may be withheld until such tax delinquency is remedied.

- E. How did you learn about this project?  
 \_\_\_\_\_

APPENDIX B  
CERTIFICATION OF NON-COLLUSION

"The undersigned affirms that they are duly authorized to execute this contract, that this company, corporation, firm, partnership or individual has not prepared this Proposal in collusion with any other Offeror, and that the contents of this Proposal as to prices, terms or conditions of said Proposal have not been communicated by the undersigned nor by any employee or agent to any other person engaged in this type of business prior to the official opening of this Proposal.

FILL IN APPLICATION INFORMATION:

A CORPORATION, chartered in the State of \_\_\_\_\_, authorized to do business in the State of TEXAS.

A Partnership, composed of: \_\_\_\_\_

An Individual, operating under the name of: \_\_\_\_\_

Respectfully Submitted,

(SEAL: If Proposal is by a Corporation)

By: \_\_\_\_\_  
Signature

\_\_\_\_\_  
Name (Print or Type)

\_\_\_\_\_  
Position with Company

DATE: \_\_\_\_\_ ADDRESS \_\_\_\_\_

PHONE: \_\_\_\_\_

FAX: \_\_\_\_\_

EMAIL: \_\_\_\_\_

APPENDIX C

Alamo Colleges District  
Purchasing and Contract Administration Department  
April 2020

Equal Employment Opportunity Act (EEOA) Affirmative Steps for  
Use of Minority Business Enterprise, Women Business Enterprises  
and Labor Surplus Area Firms

and

Guidelines on Utilization of  
Small, Minority, Women and/or Veteran Business Enterprise  
(SMWVBE)



# ALAMO COLLEGES DISTRICT

## Alamo Colleges District

### SMWVBE Program

## Guidelines on Utilization of Small, Minority, Women and/or Veteran Business Enterprise (SMWVBEs)

### *Table of Contents*

- Equal Employment Opportunity Act (EEOA) Affirmative Steps Requirements and Alamo Colleges District SMWVBE Program page 37
- Alamo Colleges District Small, Minority, Women and/or Veteran Owned Business Enterprise Clause page 38-39
- SMWVBE Letter of Acknowledgement page 40
- SMWVBE Subcontracting Plan page 41-43
- SMWVBE Subcontracting Plan Diversity Reporting page 44
- SMWVBE Helpful Resource Contacts page 44

# Equal Employment Opportunity Act (EEOA) Affirmative Steps Requirements and Alamo Colleges District SMWVBE Program

## EEOC REQUIREMENTS

This Project is funded in whole or in part by a grant from the Economic Development Administration (EDQ) of the U.S. Department of Commerce. The Contractor is required to comply with the federal laws identified in Section HH of the Instructions, including the Equal Employment Opportunity Act.

The Equal Employment Opportunity Act requires the selected Contractor and subcontractors to take all necessary affirmative steps to assure that Minority Business Enterprises, Women Business Enterprises, and Labor Surplus Area Firms are used in the Project when possible ("Affirmative Steps").

Affirmative Steps must include:

- (1) Placing qualified small and minority businesses and women's business enterprise on solicitation lists;
- (2) Assuring that small and minority businesses, and women's business enterprise are solicited whenever they are potential sources;
- (3) Dividing total requirements, when economically feasible, into smaller tasks or quantities to permit maximum participation by small and minority businesses, and women's business enterprises;
- (4) *Establishing delivery schedules, where the requirement permits, which encourage participation by small and minority businesses, and women's business enterprises;*
- (5) *Using the services and assistance, as appropriate, of such organizations as the Small Business Administration and the Minority Business Development Agency of the Department of Commerce; and*
- (6) *Requiring Subcontracts to take the affirmative steps listed in paragraphs (1) through (5) of this section.*

## ALAMO COLLEGES DISTRICT SMWVBE PROGRAM

It is the policy of Alamo Colleges District to encourage the use of Small, Minority, Women and/or Veteran-Owned Business Enterprises (SMWVBE) and Historically Underutilized Businesses (HUBs) as herein below defined to assist the College and District departments in the implementation of this policy through race, ethnicity, and gender-neutral means. The purpose of this program is to ensure that SMWVBE's are provided the maximum practicable opportunity to participate in all supplier and contracting opportunities.

## OFFEROR REQUIREMENTS

Offerors are required to:

- (1) Follow the Affirmative Steps in selecting subcontractors and suppliers for this Project, and
- (2) Submit the Letter and SMWVBE Subcontracting Plan with their proposal.

## ALAMO COLLEGES DISTRICT SMALL MINORITY WOMEN AND/OR VETERAN OWNED BUSINESS ENTERPRISE CLAUSE

Alamo Colleges District, its contractors, their subcontractors and suppliers, as well as all suppliers of all goods and services, shall not discriminate on the basis of race, color, religion, national origin, disability, gender or sexual orientation in the award and/or performance of contracts. All individuals and entities doing business, or anticipating doing business, with Alamo Colleges District are encouraged to support and implement a program designed to achieve the goal of establishing equal opportunity for all. SMWVBE groups include:

Black Americans - which includes persons having origins in any of the Black racial groups of Africa; Hispanic Americans - which includes persons of Mexican, Puerto Rican, Cuban, Central or South American, or other Spanish or Portuguese culture or origin, regardless of race; Asian Pacific Americans - which includes persons whose origins are from Japan, China, Taiwan, Korea, Vietnam, Laos, Cambodia, the Philippines, Samoa, Guam, the U.S. Trust Territories of the Pacific and the Northern Marianas; Native American - which includes persons who are American Indians, Eskimos, Aleuts, or Native Hawaiians; Women - which includes all women of any ethnicity; and Small Business Enterprise.

Alamo Colleges District Purchasing and Contract Administration Department maintains an active program for the identification and placement of SMWVBE's on solicitation mailing lists, and to provide information and other assistance to facilitate the use of such firms as contractors to the maximum extent practical. SMWVBE's seeking contracting opportunities should file a "Vendor Registration" with the Alamo Colleges District Purchasing and Contract Administration Department, 2222 N. Alamo St., San Antonio, Texas 78215; telephone 210-485-0100 or at <https://alamo.diversitycompliance.com/>.

Firms seeking contracting opportunities will be encouraged to use their best efforts to carry out this practice through subcontracting of small and/or minority business enterprises to the fullest extent consistent with efficient performance.

### DEFINITIONS

#### 1. TYPES OF ENTERPRISES

##### A. Minority Business Enterprise:

Means a business enterprise that is owned/controlled and operated by one or more minority person(s). Minority persons include Blacks, Mexican-Americans and other persons of Hispanic origin, American Indians, Alaskan Natives, and Asians and Pacific Islanders. Minority person(s) shall collectively own, operate, and share in payments from such an enterprise in the manner hereinafter set forth.

##### B. Small Business Enterprise:

Means a corporation, partnership, sole proprietorship or other legal entity for the purpose of making a profit, which is independently owned and operated, which includes small businesses as defined by certification agency.

##### C. Women's Business Enterprise:

Means a sole proprietorship that is owned and controlled by a woman, a partnership at least 51.0% of whose assets or partnership interests are owned by one or more women, or a corporation, limited liability Company, or other form of entity, at least 51.0% of whose assets or ownership interests are owned by one or more women.

D. Veteran Business Enterprise:

Means a business structure that is at least 51% owned, operated and controlled by an individual who served in the United States Armed Forces, and who was discharged or released under conditions other than dishonorable. NOTE: This certification type should not be confused with the Service Disabled Veteran designation available through the Small Business Administration.

E. Labor Surplus Areas are government-designated towns and counties (or portions of them) that have experienced severe unemployment. These areas are designated by the federal government in a yearly survey. Such a designation is then linked to federal procurement policies aimed at reducing unemployment. Offerors may solicit firms or businesses from these areas as part of the Affirmative Steps.

The current list of Labor Surplus Areas in Texas can be found on the U.S. Department of Labor website: [https://www.dol.gov/sites/dolgov/files/eta/lsa/pdfs/2020\\_lsa\\_list.xlsx](https://www.dol.gov/sites/dolgov/files/eta/lsa/pdfs/2020_lsa_list.xlsx)

## 2. OWNERSHIP AND CONTROL

A. Owned:

1. For a sole proprietorship to be deemed minority business enterprise, it must be owned by a minority person.
2. For an enterprise doing business as a partnership, it is necessary that at least 51.0% of its assets or interests in the partnership property be owned by one or more minority person(s).
3. For an enterprise doing business as a corporation, limited liability Company, or other form of entity, it is necessary that at least 51.0% of its assets or ownership interests be owned by one or more minority person(s).

B. Controlled/Operated:

That the primary power to manage a business enterprise shall rest with minority person(s).

C. Share in Payments:

Minority partners, proprietor, members, stockholders or other owners of the enterprise, as the case may be, shall be entitled to receive 51.0% or more of the total profits, bonuses, dividends, interest payments, commissions, consulting fees, rents, procurement, and subcontractor payments, and any other monetary distribution paid by the business enterprise.

## (RESPONDENT'S BUSINESS LETTERHEAD)

Date

Mr. Gary O'Bar  
Director, Purchasing and Contract Administration  
Alamo Colleges District  
2222 N. Alamo St.  
San Antonio, TX 78215

Re: Affirmative Steps Requirements and Small, Minority, Women and/or Veteran Owned Business Enterprise (SMWVBE) Subcontracting Plan for: Purchase of Construction Services for Renovations to the Eastside Education Training Center (EETC) for Alamo Colleges District

Dear Mr. O'Bar:

I have read and understand (i) the requirements for taking Affirmative Steps in the solicitation of SMWVBE's and Labor Surplus Area firms, and (ii) the Alamo Colleges District guidelines for the utilization of Small Minority Women and/or Veteran Owned Business Enterprise (SMWVBE).

This (SMWVBE) subcontracting plan will include subcontracting opportunities representing an estimated cumulative percentage of \_\_\_\_\_%.

I acknowledge that if I am selected as the construction Contractor for this Project, I will be required to provide the attached subcontracting plan inclusive of all (SMWVBE) subcontractors and their certification document by an approved certifying agency. By completion of Section "6" of the (SMWVBE) subcontracting plan, I affirm my intent to utilize the subcontractors selected to perform the scope of work to be subcontracted.

Should we discover additional subcontractors claiming (SMWVBE) status during the course of this contract we will notify you of the same. Should we discover the need for additional subcontractors or suppliers during the course of construction, we will follow the Affirmative Steps in selecting them and notify you of the same. In addition, if for some reason a (SMWVBE) is unable to fulfill its contract with us, we will notify you immediately in order to take the appropriate steps to amend this contractual obligation. We will require subcontractors to comply with the Affirmative Step requirements.

We further understand that, if selected, we will be required to keep records and evidence of the Affirmative Steps that we have taken throughout the Project and to comply with any reporting and recordkeeping requirements for this Project established by the EDA grant program and/or federal law.

Sincerely,

(Project Executive)



# ALAMO COLLEGES DISTRICT SMWVBE SUBCONTRACTING PLAN

## -- Special Instructions/Additional Requirements --

- Respondents shall submit a completed SMWVBE Subcontracting Plan to be considered responsive (pages 7, 8, and 9). Failure to submit a completed Subcontracting Plan shall result in point(s) reduction in the evaluation process for the bid and/or proposal.
- Respondents who intend to Self-Perform all of their work shall submit a Subcontracting Plan for Self-Performance (Section 7).
- SMWVBE Subcontracting Plan Prime Contractor Payment Request Form page 11 shall be submitted with each request for payment as a condition of payment.

### SECTION 1 - RESPONDENT AND SOLICITATION INFORMATION

- a. Respondent (Company) Name: \_\_\_\_\_  
 Point of Contact: \_\_\_\_\_ Phone #: \_\_\_\_\_
- b. Is your company a certified SMWVBE?  - Yes  - No
- c. CSP #: \_\_\_\_\_

### SECTION 2 - SUBCONTRACTING INTENTIONS

- Yes, I will be subcontracting portion(s) of the contract.  
 (If yes, in the spaces provided below, list the portions of work you will be subcontracting, and go to page 9.)
- No, I will not be subcontracting any portion of the contract, and will be fulfilling the entire contract with my own resources.

Line Item # - Subcontracting Opportunity Description	Line Item # - Subcontracting Opportunity Description
#1) -	#11) -
#2) -	#12) -
#3) -	#13) -
#4) -	#14) -
#5) -	#15) -
#6) -	#16) -
#7) -	#17) -
#8) -	#18) -
#9) -	#19) -
#10) -	#20) -

**IMPORTANT:** You must complete a copy of this page for each of the subcontracting opportunities you listed in SECTION 2.

You may photocopy this page.

**SECTION 3 - SUBCONTRACTING OPPORTUNITY**

Enter the line item number and description of the subcontracting opportunity you listed in SECTION 2.

Line Item # \_\_\_\_\_ Description: \_\_\_\_\_

**SECTION 4 - NOTIFICATION OF SUBCONTRACTING OPPORTUNITY**

Complying with a, b and c of this section constitutes Good Faith Effort towards the portion of work listed in SECTION 3. After performing the requirements of this section, complete SECTION 5, 6 and 8.

- a. Provide written notification of the subcontracting opportunity listed in SECTION 3 to three (3) or more SMWVBEs. You can use the State of Texas' Centralized Master Bidders List (CMVL), found at <http://www.window.state.tx.us/procurement/cmb/cmbclub.html> and its HUB Directory found at <http://www.window.state.tx.us/procurement/cmb/hubonly.html>. Also, the South Texas Regional Certification Agency's (STRCA) database at <http://strca.org/> to identify available SMWVBEs. NOTE: Attach supporting documentation (letters, phone logs, fax transmittals, electronic mail, etc.) demonstrating evidence of the good faith effort performed.
- b. Provide written notification of the subcontracting opportunity listed in SECTION 3 to a minority or women trade organization or development center to assist in identifying potential SMWVBEs by disseminating the subcontracting opportunity to their members/participants. Attach supporting documentation (letters, phone logs, fax transmittals, electronic mail, etc.) demonstrating evidence of the good faith effort performed.
- c. Written notifications should include the scope of the work, information regarding the location to review plans and specifications, bonding and insurance requirements, required qualifications, and identify a contact person. Unless the contracting agency has specified a different time period, you must allow the SMWVBEs no less than five (5) working days from their receipt of notice to respond, and provide notice of your subcontracting opportunity to a minority or women trade organization or development center no less than five (5) working days prior to the submission of your response to the contracting agency.

**SECTION 5 - SMWVBE FIRMS CONTACTED FOR SUBCONTRACTING OPPORTUNITY**

List three (3) certified SMWVBEs you notified regarding the portion of work (subcontracting opportunity) listed in SECTION 3. Specify the vendor ID number, date you provided notice, and if you received a response. Note: Attach supporting documentation (letters, phone logs, fax transmittals, electronic mail, etc.) demonstrating evidence of the good faith effort performed.

Company Name	VID #	Notice Date (mm/dd/yyyy)	Was Response Received?
_____	_____	____/____/____	<input type="checkbox"/> - Yes <input type="checkbox"/> - No
_____	_____	____/____/____	<input type="checkbox"/> - Yes <input type="checkbox"/> - No
_____	_____	____/____/____	<input type="checkbox"/> - Yes <input type="checkbox"/> - No

**SECTION 6 - SUBCONTRACTOR SELECTION**

List all the subcontractor(s), both SMWVBE and non-SMWVBE, you selected to perform the portion of work (subcontracting opportunity) listed in SECTION 3. Also, specify the expected percentage of work to be subcontracted, the approximate dollar value of the work to be subcontracted, and indicate if the company is a SMWVBE.

Company Name	VID #	Expected % of Contract	Approximate Dollar Amount	Certified SMWVBE?
_____	_____	____%	\$ _____	<input type="checkbox"/> - Yes <input type="checkbox"/> - No*
_____	_____	____%	\$ _____	<input type="checkbox"/> - Yes <input type="checkbox"/> - No*
_____	_____	____%	\$ _____	<input type="checkbox"/> - Yes <input type="checkbox"/> - No*
_____	_____	____%	\$ _____	<input type="checkbox"/> - Yes <input type="checkbox"/> - No*
_____	_____	____%	\$ _____	<input type="checkbox"/> - Yes <input type="checkbox"/> - No*
_____	_____	____%	\$ _____	<input type="checkbox"/> - Yes <input type="checkbox"/> - No*

\*If the subcontractor(s) you selected is not a SMWVBE, provide written justification of your selection process below:

\_\_\_\_\_

\_\_\_\_\_

\_\_\_\_\_

**SECTION 7 - SELF PERFORMANCE JUSTIFICATION**

(If you responded "No" to SECTION 2, you must complete SECTION 7 and 8.)

Does your response/proposal contain an explanation demonstrating how your company will fulfill the entire contract with its own resources?

- Yes If Yes, in the space provided below, list the specific page/section of your proposal which identifies how your company will perform the entire contract with its own equipment, supplies, materials and/or employees.

No. If No, in the space provided below, explain how your company will perform the entire contract with its own equipment, supplies, materials, and/or employees.

---

---

---

---

---

---

---

---

---

---

---

---

**SECTION 8 - AFFIRMATION**

As evidenced by my signature below, I affirm that I am an authorized representative of the respondent listed in SECTION 1, and that the information and supporting documentation submitted with the SMWVBE Subcontracting Plan are true and correct. Respondent understands and agrees that, if awarded any portion of the solicitation:

- The respondent must submit monthly compliance reports (Payment Request Forms) to Alamo Colleges District, verifying their compliance with the SMWVBE Subcontracting Plan, including the use/expenditures they have made to subcontractors.
- The respondent must seek approval from Alamo Colleges District prior to making any modifications to their SMWVBE Subcontracting Plan.
- The respondent must, upon request, allow Alamo Colleges District to perform on-site reviews of the company's headquarters and/or work-site where services are to be performed and must provide documents regarding staff and other resources.

Signature	Printed Name	Title	Date
-----------	--------------	-------	------

## SMWVBE Subcontracting Plan Diversity Reporting

Diversity Reporting: This contract is subject to contract compliance tracking, and the prime contractor and any subcontractors are required to provide any noted and/or requested contract compliance-related data electronically in the B2GNow Supplier diversity Management Systems. The prime contractor and all subcontractors are responsible for responding by any noted response date or due date to any instructions or request for information, and to check the B2Gnow Supplier Diversity Management System on a regular basis to manage contact information and contract records. The prime contractor is responsible for ensuring all subcontractors have completed all requested items and that their contact information is accurate and up-to-date. Alamo Colleges District may require additional information related to the contract to be provided electronically through the system at any time before, during, or after contract award. Information related to contractor access of the system will be provided to a designated point of contact with each contractor upon award of the contract. The B2Gnow Supplier Diversity Management System is web-based and can be accessed through an internet address which will be provided to the Contractor and Contractor's subcontractors.

### SMWVBE Helpful Resource Contacts

Alamo Colleges District Purchasing and Contract Administration  
2222 N. Alamo St., San Antonio, TX 78215  
Karen Gottfried, Assistant Director, [kgottfried@alamo.edu](mailto:kgottfried@alamo.edu), 210/485-0122  
Tarence White, SMWVBE Coordinator, [twhite85@alamo.edu](mailto:twhite85@alamo.edu), 210/485-0127

Websites – the following websites will assist in the ability to search or identify HUB and SMWVBE firms:

The South Central Texas Regional Certification Agency:  
<http://sctrca.org/>

Texas Procurement and Support Services Division  
<http://www.window.state.tx.us/procurement/cmb/cmbhub.html>

The current list of Labor Surplus Areas in Texas can be found at:  
[https://www.dol.gov/sites/dolgov/files/eta/lsa/pdfs/2020\\_lsa\\_list.xlsx](https://www.dol.gov/sites/dolgov/files/eta/lsa/pdfs/2020_lsa_list.xlsx)

APPENDIX D

**CONFLICT OF INTEREST QUESTIONNAIRE**

FORM CIQ

For vendor or other person doing business with local governmental entity

This questionnaire reflects changes made to the law by H.B. 1491, 80<sup>th</sup> Leg., Regular Session.

**OFFICE USE ONLY**

This questionnaire is being filed in accordance with Chapter 176, Local Government Code  
By a person who has a business relationship as defined by Section 176.00(1-a) with a local  
Governmental entity and the person meets requirements under Section 176.006(a).

By law this questionnaire must be filed with the records administrator of the local governmental entity  
not later than the 7<sup>th</sup> business day after the date the person becomes aware of facts  
that require the statement to be filed. See Section 176.006, Local Government Code.

A person commits an offense if the person knowingly violates Section 176.006, Local Government Code.  
An offense under this section is a Class C misdemeanor.

**1** Name of person who has a business relationship with local governmental entity.

**2**  Check this box if you are filing an update to a previously filed questionnaire.  
(This law requires that you file an update completed questionnaire with the appropriate filing authority not  
later than the 7<sup>th</sup> business day after the date the originally filed questionnaire becomes incomplete or inaccurate.)

**3** Name of local government officer with whom filer has employment or business relationship.

\_\_\_\_\_  
Name of Officer

This section (item 3 including subparts A, B, C & D) must be completed for each officer with whom the filer has an employment or other business  
relationship as defined by Section 176.001(1-a), Local Government Code. Attach additional pages to this Form CIQ as necessary.

A. Is the local government officer named in this section receiving or likely to receive taxable income, other than investment income, from the  
filer of the questionnaire?

Yes       No

B. Is the filer of the questionnaire receiving or likely to receive taxable income, other than investment income, from or at the direction of the  
local government officer named in this section AND the taxable income is not received from the local governmental entity?

Yes       No

C. Is the filer of this questionnaire employed by a corporation or other business entity with respect to which the local government officer serves  
as an officer or director, or holds an ownership of 10 percent or more?

Yes       No

D. Describe each employment or business relationship with the local government officer named in this section.

**4**

\_\_\_\_\_  
Signature of person doing business with the governmental entity

\_\_\_\_\_  
Date

APPENDIX E  
PAYMENT BOND

The Payment Bond must be on the following forms, or on other forms approved by Owner.

Payment Bond

STATE OF TEXAS  
COUNTY OF \_\_\_\_\_

Bond No. \_\_\_\_\_  
C.I.P. No. \_\_\_\_\_  
Project Name \_\_\_\_\_

Know All Men By These Presents: That \_\_\_\_\_ of the City of \_\_\_\_\_, County of \_\_\_\_\_ and State of \_\_\_\_\_, as principal, and \_\_\_\_\_ a solvent corporation authorized under laws of the State of Texas to act as surety on bonds for principals, are held and firmly bound unto \_\_\_\_\_ (Owner), and all Subcontractors, workers, laborers, mechanics and suppliers as their interests may appear, all of whom shall have right to sue upon this bond in the penal sum of \_\_\_\_\_ U.S. Dollars (\$ \_\_\_\_\_ U.S.), for payment whereof, well and truly to be made, said Principal and Surety bind themselves and their heirs, administrators, executors, successors and assigns, jointly and severally, by these presents:

Conditions of this Bond are such that, whereas, Principal has entered into a certain written contract with Owner; dated the \_\_\_\_\_ day of \_\_\_\_\_, \_\_\_\_\_ to which Agreement is hereby referred to and made a part hereof as fully and to the same extent as if copied in length herein.

Now, therefore, condition of this obligation is such, that if the said Principal shall well and truly pay all Subcontractors, workers, laborers, mechanics, and suppliers, all monies to them owing by said Principals for subcontracts, work, labor, equipment, supplies and materials done and furnished for the construction of improvement of said Agreement, then this obligation shall be and become null and void; otherwise to remain in full force and effect.

Provided, however, that this bond is executed pursuant to provisions of Chapter 2253, Texas Government Code as amended and all liabilities on bond shall be determined in accordance with provisions of said Article to same extent as if it were copied at length herein.

Surety, for value received, stipulates and agrees that any change in Contract Time or Contract Sum shall not in anywise affect its obligation on this bond, and it does hereby waive notice of any such change in Contract Time or Contract Sum.

In witness whereof, said Principal and Surety have signed and sealed this instrument this \_\_\_\_\_ day of \_\_\_\_\_, \_\_\_\_\_.

\_\_\_\_\_  
Principal  
By \_\_\_\_\_  
Title \_\_\_\_\_  
Address \_\_\_\_\_  
\_\_\_\_\_  
\_\_\_\_\_

\_\_\_\_\_  
Surety  
By \_\_\_\_\_  
Title \_\_\_\_\_  
Address \_\_\_\_\_  
\_\_\_\_\_  
\_\_\_\_\_

Telephone \_\_\_\_\_  
Fax \_\_\_\_\_  
E-Mail Address \_\_\_\_\_  
Name and address of the Resident Agent of Surety:  
\_\_\_\_\_  
\_\_\_\_\_

Note: Bond shall be issued by a solvent Surety company authorized to do business in Texas, and shall meet any other requirements established by law and by OWNER in the Contract Documents. A copy of surety agent's "Power of Attorney" must be attached hereto.

APPENDIX F
PERFORMANCE BOND

The Performance Bond must be on the following forms, or on other forms approved by Owner.

Performance Bond

STATE OF TEXAS
COUNTY OF \_\_\_\_\_

Bond No. \_\_\_\_\_
C.I.P. No. \_\_\_\_\_
Project Name \_\_\_\_\_

Know All Men By These Presents: That \_\_\_\_\_ of the City of \_\_\_\_\_, County of \_\_\_\_\_, and State of \_\_\_\_\_, as Principal, an \_\_\_\_\_, a solvent company authorized under laws of the State of Texas to act as surety on bonds for principals, are held and firmly bound unto \_\_\_\_\_ (OWNER), in the penal sum of \_\_\_\_\_ U.S. Dollars (\$ \_\_\_\_\_ U.S.) for payment whereof, well and truly to be made, said Principal and Surety bind themselves and their heirs, administrators, executors, successors and assigns, jointly and severally, by these presents:

Conditions of this Bond are such that, whereas, Principal has entered into a certain written contract with OWNER, dated the \_\_\_\_\_ day of \_\_\_\_\_, \_\_\_\_\_, which Agreement is hereby referred to and made a part hereof as fully and to the same extent as if copied at length herein.

Now, therefore, the condition of this obligation is such, that if said Principal shall faithfully perform said Agreement and shall in all respects duly and faithfully observe and perform all and singular covenants, conditions and agreements in and by said contract agreed and covenanted by Principal to be observed and performed, and according to true intent and meaning of said Agreement hereto annexed, then this obligation shall be void; otherwise to remain in full force and effect.

Provided, however, that this bond is executed pursuant to provisions of Chapter 2253, Texas Government Code as amended and all liabilities on this bond shall be determined in accordance with provisions of said Article to same extent as if it were copied at length herein.

Surety, for value received, stipulates and agrees that any change in Contract Time or Contract Sum shall not in anywise affect its obligation on this bond, and it does hereby waive notice of any such change in Contract Time or Contract Sum.

In witness whereof, said Principal and Surety have signed and sealed this instrument this \_\_\_\_\_ day of \_\_\_\_\_, \_\_\_\_\_.

Principal
By \_\_\_\_\_
Title \_\_\_\_\_
Address \_\_\_\_\_
Telephone \_\_\_\_\_
Fax \_\_\_\_\_
E-Mail Address \_\_\_\_\_

Surety
By \_\_\_\_\_
Title \_\_\_\_\_
Address \_\_\_\_\_

Name and address of Resident Agent of Surety:
\_\_\_\_\_
\_\_\_\_\_

Note: Bond shall be issued by a solvent Surety company authorized to do business in Texas, and shall meet any other requirements established by law and by OWNER in the Contract Documents. A copy of surety agent's "Power of Attorney" must be attached hereto.

APPENDIX G  
ANTI-LOBBYING CERTIFICATION

BYRD ANTI-LOBBYING AMENDMENT CERTIFICATION  
(To be submitted with each bid or offer exceeding \$100,000)

The undersigned, on behalf of {Company} \_\_\_\_\_ certifies, to the best of his or her knowledge, that:

1. No Federal appropriated funds have been paid or will be paid, by or on behalf of the undersigned, to any person for influencing or attempting to influence an officer or employee of an agency, a Member of Congress, an officer or employee of Congress, or an employee of a Member of Congress in connection with the awarding of any Federal contract, the making of any Federal grant, the making of any Federal loan, the entering into of any cooperative agreement, and the extension, continuation, renewal, amendment, or modification of any Federal contract, grant, loan, or cooperative agreement.
2. If any funds other than Federal appropriated funds have been paid or will be paid to any person for influencing or attempting to influence an officer or employee of any agency, a Member of Congress, an officer or employee of Congress, or an employee of a Member of Congress in connection with this Federal contract, grant, loan, or cooperative agreement, the undersigned shall complete and submit Standard Form – LLL. “Disclosure Form to Report Lobbying,” in accordance with its instructions.
3. The undersigned shall require that the language of this certification be included in the award documents for all subawards at all tiers (including subcontracts, subgrants, and contracts under grants, loans, and cooperative agreements) and that all subrecipients shall certify and disclose accordingly.

This certification is a material representation of fact upon which reliance was placed when this transaction was made or entered into. Submission of this certification is a prerequisite for making or entering into this transaction imposed by 31, U.S.C. § 1352 (as amended by the Lobbying Disclosure Act of 1995). Any person who fails to file the required certification shall be subject to a civil penalty of not less than \$10,000 and not more than \$100,000 for each such failure.

The Contractor, {Company} \_\_\_\_\_, certifies or affirms the truthfulness and accuracy of each statement of its certification and disclosure, if any. In addition, the Contractor understands and agrees that the provisions of 31 U.S.C. § 3801 *et seq.*, apply to this certification and disclosure, if any.

\_\_\_\_\_  
Signature of Contractor’s Authorized Official

\_\_\_\_\_  
Name and Title of Contractor’s Authorized Official

\_\_\_\_\_  
Date





## INSTRUCTIONS FOR COMPLETION OF SF-LLL, DISCLOSURE OF LOBBING ACTIVITIES

This disclosure form shall be completed by the reporting entity, whether sub-awardee or prime Federal recipient, at the initiation or receipt of covered Federal action or a material change to previous filing pursuant to title 31 U.S.C. section 1352. The filing of a form is required for such payment or agreement to make payment to lobbying entity for influencing or attempting to influence an officer or employee of any agency, a Member of Congress, an officer or employee of Congress, or an employee of a Member of Congress in connection with a covered Federal action. Attach a continuation sheet for additional information if the space on the form is inadequate. Complete all items that apply for both the initial filing and material change report. Refer to the implementing guidance published by the Office of Management and Budget for additional information.

1. Identify the type of covered Federal action for which lobbying activity is and/or has been secured to influence, the outcome of a covered Federal action.
2. Identify the status of the covered Federal action.
3. Identify the appropriate classification of this report. If this is a follow-up report caused by a material change to the information previously reported, enter the year and quarter in which the change occurred. Enter the date of the last, previously submitted report by this reporting entity for this covered Federal action.
4. Enter the full name, address, city, state and zip code of the reporting entity. Include Congressional District if known. Check the appropriate classification of the reporting entity that designates if it is or expects to be a prime or subaward recipient. Identify the tier of the sub-awardee, e.g., the first sub-awardee of the prime is the first tier. Subawards include but are not limited to subcontracts, subgrants and contract awards under grants.
5. If the organization filing the report in Item 4 checks "Sub-Awardee" then enter the full name, address, city, state and zip code of the prime Federal recipient. Include Congressional District, if known.
6. Enter the name of the Federal agency making the award or loan commitment. Include at least one organization level below agency name, if known. For example, Department of Transportation, United States coast Guard.
7. Enter the Federal program name or description for the covered Federal action (item 1). If known, enter the full Catalog of Federal Domestic Assistance (CFDA) number for grants, cooperative agreements, loans and loan commitments.
8. Enter the most appropriate Federal identifying number available for the Federal action identification in item 1 (e.g., Request for Proposal (RFP) number, Invitation for Bid (IFB) number, grant announcement number, the contract grant, or loan award number, the application/proposal control number assigned by the Federal agency). Include prefixes, e.g., "RFP-DE-90-001."
9. For a covered Federal action where there has been an award or loan commitment by the Federal agency, enter the Federal amount of the award/loan commitments for the prime entity identified in item 4 or 5.
10. (a) Enter the full name, address, city, state and zip code of the lobbying entity engaged by the reporting entity identified in item 4 to influenced the covered Federal action.  
(b) Enter the full names of the individual(s) performing services and include full address if different from 10 (1). Enter Last Name, First Name and Middle Initial (MI).
11. Enter the amount of compensation paid or reasonably expected to be paid by the reporting entity (item 4) to the lobbying entity (item 10). Indicate whether the payment has been made (actual) or will be made (planned). Check all boxes that apply. If this is a material change report, enter the cumulative amount of payment made or planned to be made.
12. Check the appropriate box. Check all boxes that apply. If payment is made through an in-kind contribution, specify the nature and value of the in-kind payment.
13. Check the appropriate box. Check all boxes that apply. If other, specify nature.
14. Provide a specific and detailed description of the services that the lobbyist has performed or will be expected to perform and the date(s) of any services rendered. Include all preparatory and related activity not just time spent in actual contact with Federal officials. Identify the Federal officer(s) or employee(s) contacted or the officer(s) employee(s) or Member(s) of Congress that were contacted.
15. Check whether or not a continuation sheet(s) is attached.
16. The certifying official shall sign and date the form, print his/her name, title and telephone number.

Public reporting burden for this collection of information is estimated to average 30 minutes per response, including time for reviewing instruction, searching existing data sources, gathering and maintaining the data needed, and completing and reviewing the collection of information. Send comments regarding the burden estimate or any other aspect of this collection of information, including suggestions for reducing this burden, to the Office of Management and Budget, Paperwork Reduction Project (0348-0046), Washington, D.C. 20503

**SECTION 6 - CONSTRUCTION AGREEMENT**

**PART I  
TERMS AND CONDITIONS**

THIS AGREEMENT, entered into and effective this \_\_\_\_\_ day of \_\_\_\_\_ 202\_\_, by and between the Alamo Community College District (sometimes Alamo Colleges, Alamo Colleges District, ACCD, District or Owner) and \_\_\_\_\_, located at \_\_\_\_\_, with Fed Tax ID No. \_\_\_\_\_ and Texas Secretary of State Filing No. \_\_\_\_\_, hereinafter called "the Contractor".

**WHEREAS**, the Owner issued \_\_\_\_\_ to retain a person or entity to \_\_\_\_\_ (hereinafter, "Project");

**WHEREAS** Contractor desires to render certain services and/or provide certain materials in connection with the Project;

**WHEREAS** the Owner desires to engage Contractor to render certain services and/or provide certain materials in connection with the Project;

**WHEREAS** the Owner has determined that the Contractor, based on its proposal for the work ("Proposal"), offers the best value or lowest bid, as applicable, for the Owner to complete the work under the Project; and

**WHEREAS**, the Owner and Contractor wish to enter into an Agreement for the Project.

**NOW, THEREFORE, CONTRACTOR and OWNER** for and in consideration of the foregoing Recitals, and for the mutual agreements herein made, the receipt and adequacy of such consideration being acknowledged by the parties to each other, the parties hereto agree as follows:

1. Scope of Services. The Contractor will perform the work and provide all the materials required to complete the Project as set out in **Part II**, Scope of Services (hereinafter referred to as the "Work"). Unless otherwise provided in **Part II** and as a component of the Work, Contractor shall (a) furnish and pay for all labor, material, tools, and equipment required for the proper execution and completion of the Work; (b) bear the cost of all freight, express, demurrage and other delivery charges for material and equipment furnished by it; and (c) be responsible for and bear the cost of unloading, storing, and moving all such material and equipment. Contractor shall comply with all applicable Owner requirements and only utilize forms approved by the Owner, including but not limited to those forms and requirements attached hereto as Exhibits and incorporated by reference herein.

2. Time of Performance. The services of the Contractor shall commence on \_\_\_\_\_. In any event, **for all of the services required and**

performed hereunder, Contractor shall obtain Final Completion no later than and not to exceed [redacted] days, from the effective date of this Agreement (“Contract Time”). However, this period may be extended, in the sole discretion of the Owner and if authorized in writing by the Owner and signed by Owner’s authorized representative.

3. Compensation and Method of Payment. The maximum amount of compensation and reimbursement to be paid hereunder shall not exceed \$ [redacted] (“Contract Sum”). Payment to the Contractor shall be based on satisfactory completion of the Scope of Service in **Part II** and in the manner identified in **Part III** - Payment Schedule of this Agreement. Owner shall withhold retainage in the amount of ten percent (10 %). If requested by Owner, any cost billed separately as a reimbursable shall be declared and included in the lump sum amount. If requested and in addition to a request for payment, invoices shall be provided by Contractor which set forth the percentage of work completed to date, establishing the amount due based upon the percentage completed, less retainage, any previous amounts billed, and/or paid to date.

4. Representatives. For purposes of this Contract, the persons identified in this section or other person authorized in writing will serve as the Representative and primary point of contact for the respective party. All required notices, progress reports and communication regarding the Project shall be directed as follows:

**To Alamo Community College District:**

Owner:

Attn: Diane Snyder, CPA, Ph.D., Vice Chancellor for Finance & Administration  
2222 N. Alamo St.

San Antonio, TX 78215

Email:

**To Contractor:**

[redacted]  
Attn: \_\_\_\_\_, \_\_\_\_\_  
\_\_\_\_\_  
\_\_\_\_\_  
Fax \_\_\_\_\_

5. Access and Retention of Records. The Contractor shall retain all records, which relate to the Project or this Agreement for twelve (12) years after the Owner makes its Final Payment. For at least twelve (12) years from the date of Final Payment under this Agreement, the Owner or any of their authorized representatives, shall have the right to audit, access, and copy any and all documents, papers, or other records of the Contractor which are pertinent to or relate to the Proposal, Project or this Agreement. The Owner and its authorized representatives and agents shall have access to and be permitted to audit, observe and review all work, materials, equipment, payrolls, personnel records, employment conditions, material invoices, and other relevant data and records pertaining to this Agreement. The Owner or any of their authorized representatives shall receive full and complete responses to questions or request for records or information within two (2) business days from Contractor.

6. Audits. The Contractor shall insure that it maintains fiscal records and supporting documentation for all expenditures of funds made under this contract in a manner that conforms to this Agreement. Owner may request said records at any time and Contractor shall promptly provide Owner with the same. In the event that an audit by the Owner reveals any errors/overpayments by the Owner, then the Contractor shall refund to the Owner the full amount of such overpayments within thirty (30) days of such audit findings, or the Owner, at its option, reserves the right to deduct such amounts owed to the Owner from any payments due to the Contractor. In addition, if an audit inspection or examination discloses overpayments (of any nature) by the Owner to the Contractor in excess of two percent (2%) of the total Contract Sum for the Project, the actual cost of the Owner's audit shall be paid by the Contractor.

7. Records Confidential. All of the plans, specifications, reports, information, data, etc., provided to, prepared or assembled by the Contractor under this Agreement (the "Records") may be confidential and shall be treated as confidential by Contractor. Further, the Contractor agrees that the foregoing Records shall not be made available to any individual or organization without the prior written approval of the Owner. All Records, drawings and documents prepared by Contractor in connection with its performance of the Work are the property of Owner and are not to be used on other projects except by agreement of Owner in writing. All such drawings and documents shall be transmitted to Owner at the completion of the Work.

8. Owner Furnished Information. The Owner may furnish information, surveys reports or services. All documents provided by Owner or its representatives shall be provided for information only and are not warranted or represented to show the actual conditions at the Project site accurately. Contractor may use the information at its own risk and shall use customary precautions relating to the performance of the Work. Contractor shall perform all work in such a non-negligent manner so as to avoid damaging any utility lines, cables, pipes, or pipelines and Contractor shall be responsible for any damage done to such lines, cables, pipes and pipelines during the Work

9. Site Conditions. Contractor acknowledges that there may exist at the project site certain soil and geological conditions and/or subsurface physical, structures, equipment, utilities, and/or other conditions which are not disclosed in the Contract Documents, and which have been known to or may be reasonably anticipated to occur in the area or be related to any past use of the project site, including, without limitation, the presence of rock and its hardness, geologic formations, differing soils, and subsurface structures, equipment, utilities, or other impediments, either natural or man-made (collectively, "Subsurface Conditions"). Owner makes no representations or warranties regarding Subsurface Conditions at the Project site, or of the accuracy or continuity of conditions which may be noted in any reports furnished or made available to Contractor. Contractor covenants and agrees that any such reports are furnished or made available by Owner to Contractor are for information purposes only, and Contractor acknowledges that Owner is not responsible for the content thereof. Contractor shall be responsible for inspecting the site and determining the existence or likelihood of any Subsurface Conditions which may affect the Contract Time or the Contract Sum, or both. The Contract Time and the Contract Sum bid by Contractor shall be deemed to include all costs of and time to complete all work associated with or attributable to Subsurface Conditions, and

Contractor shall not be entitled to submit a claim for or to obtain an extension of the Contract Time or increase in the Contract Sum due to the existence of Subsurface Conditions.

If the Contractor encounters conditions at the site that are (1) subsurface or otherwise concealed physical conditions that differ materially from those indicated in the Contract Documents or (2) unknown physical conditions of an unusual nature, that differ materially from those ordinarily found to exist and generally recognized as inherent in construction activities of the character provided for in the Contract Documents, the Contractor shall promptly provide notice to the Owner and the Architect before conditions are disturbed and in no event later than three (3) work days after first observance of the conditions. Contractor agrees that this is a reasonable notice requirement. Contractor's claims under this provision are limited to Claims for Additional Time, provided they are made in compliance with this Agreement. As part of such claim, the Architect will promptly investigate such conditions and report findings and a recommended resolution in writing to Owner and Contractor, which is limited to an extension of the Contract Time.

**10. INDEMNIFICATION – TO THE FULLEST EXTENT PERMITTED BY LAW, THE CONTRACTOR SHALL WAIVE AND RELEASE ALL CLAIMS AGAINST AND SHALL INDEMNIFY AND HOLD HARMLESS THE OWNER, ARCHITECT, OWNER'S TRUSTEES, ARCHITECT'S CONSULTANTS, OWNER'S CONSULTANTS AND OFFICERS, AGENTS AND EMPLOYEES OF ANY OF THEM, INDIVIDUALLY OR COLLECTIVELY, FROM AND AGAINST CLAIMS, DAMAGES, LOSSES, CAUSES OF ACTION, SUITS, JUDGMENTS, PENALTY AND EXPENSES, INCLUDING BUT NOT LIMITED TO ATTORNEYS' FEES, COST OF COURT, EXPERT WITNESS FEES AND COSTS ARISING OUT OF OR RESULTING FROM THE PERFORMANCE OR NONPERFORMANCE OF THE WORK, ACTIVITIES, SERVICES, OR SUBJECT MATTER OF THIS AGREEMENT, PROVIDED THAT SUCH CLAIM, DAMAGE, LOSS OR EXPENSE IS ATTRIBUTABLE TO BODILY INJURY, SICKNESS, DISEASE OR DEATH, OR TO INJURY TO OR DESTRUCTION OF TANGIBLE PROPERTY (INCLUDING THE WORK ITSELF AND INCLUDING LOSS OF USE RESULTING THEREFROM) OR CLAIMS BROUGHT BY THIRD PARTIES, CONTRACTORS, CONTRACTOR'S SUBCONTRACTORS OF ANY TIER, BUT ONLY TO THE EXTENT CAUSED IN WHOLE OR IN PART BY WILLFUL OR NEGLIGENT ACTS OR OMISSION OF THE CONTRACTOR, A SUBCONTRACTOR, ANYONE DIRECTLY OR INDIRECTLY EMPLOYED BY THEM, ANYONE THEY CONTROL OR EXERCISE CONTROL OVER, OR ANYONE FOR WHOSE ACTS THEY MAY BE LIABLE, REGARDLESS OF WHETHER OR NOT SUCH CLAIM, DAMAGE, LOSS OR EXPENSE IS CAUSED IN PART BY ANY WILLFUL OR NEGLIGENT ACT OR OMISSION OF OWNER OR OWNER'S CONSULTANTS OR OTHER INDEMNIFIED PARTIES. SUCH OBLIGATIONS SHALL NOT BE CONSTRUED TO NEGATE, ABRIDGE, OR REDUCE OTHER RIGHTS OR OBLIGATIONS OF INDEMNITY THAT WOULD OTHERWISE EXIST AS TO A PARTY OR PERSON DESCRIBED IN THIS SECTION. ALL COSTS AND EXPENSES SO INCURRED BY ANY OF THE INDEMNIFIED PARTIES IN THAT EVENT SHALL BE REIMBURSED BY CONTRACTOR TO THE INDEMNIFIED PARTIES, AND ANY COST AND EXPENSES SO INCURRED BY INDEMNIFIED PARTIES SHALL BEAR INTEREST UNTIL REIMBURSED BY CONTRACTOR, AT THE**

**RATE OF INTEREST PROVIDED TO BE PAID BY THE JUDGMENT UNDER THE LAWS OF THE STATE OF TEXAS.**

11. Insurance. Notwithstanding anything appearing elsewhere with lower limits, Contractor and its subcontractors agrees to maintain, through the duration of the Agreement and for two years following the termination of the Agreement, in force automobile liability insurance, commercial general liability insurance, professional liability insurance (if providing professional services), Contractor's public liability insurance, contractual liability insurance, property damage liability, personal and accidental injury and products/completed operation with limits of at least \$1,000,000 per occurrence and \$2,000,000 general aggregate. In addition, Contractor agrees to maintain an umbrella policy with at least a \$3,000,000 limit in excess of all underlying liability policy limits for two years following the termination of the Agreement. Contractor additionally agrees to maintain in force, and to require its subcontractors to maintain in force, workers' compensation coverage, to include alternate employees and borrowed servants, in accordance with statutory requirements under Texas law. Upon Owner's request at any time, Contractor, shall procure and maintain a Builders Risk policy in a form and amount acceptable to Owner. Contractor shall provide proof of insurance coverages to Owner, including but not limited to a certificate of insurance or policies naming the Owner as an additional named insured as to all coverages except workers compensation and providing for at least thirty (30) days written notice of any amendment, cancellation, or expiration of any coverage. All insurance must be written in a form acceptable to the Owner.

No Work on the Project shall commence and no equipment or materials can be shipped until all Insurance requirements are satisfied, satisfactory evidence of insurance has been provided to Owner, and all insurance is in full force and effect. Contractor shall notify Owner in writing of any: (i) proposed nonconformity with these insurance requirements; and (ii) changes to the insurance coverages. Any nonconformity or lack of required insurance may be grounds for termination or modification of the Contract.

Contractor further agrees to the following special provisions:

a. Contractor hereby waives subrogation rights for loss or damage to the extent same are covered by insurance. Insurers shall have no right of recovery or subrogation against the Owner. It being the intention that the insurance policies shall protect all parties to the Agreement and be primary coverage for all losses covered by the policies. This Waiver of Subrogation shall be included, by endorsement or otherwise, as a provision of all policies required hereunder.

b. Insurance companies issuing the insurance policies and Contractor shall have no recourse against the Owner for payment of any premiums or assessments for any deductibles, as all such premiums and deductibles are the sole responsibility and risk of Contractor.

c. Approval, disapproval or failure to act by the Owner regarding any insurance supplied by Contractor (or any Subcontractors) shall not relieve Contractor of any responsibility or liability for damage or accidents as set forth in the Contract

Documents. The bankruptcy, insolvency or denial of liability of or by Contractor's insurance company shall likewise not exonerate or relieve Contractor from liability.

d. The Owner reserves the right to review the insurance requirements of this Agreement at any time and to adjust the lines of insurance coverage and their limits when deemed necessary and prudent by the Owner. Contractor agrees to make any reasonable request for deletion, revision or modification of particular policy terms, conditions, limitations or exclusions (except where policy provisions are established by law or regulation binding upon either party to this Agreement or upon the underwriter of any such policy provisions). Upon written request by the Owner, Contractor shall exercise reasonable efforts to accomplish such changes in policy lines of coverage; and upon written request by Contractor, Owner shall pay Contractor for all extra costs, without any markup, incurred in effecting the changes to the policies.

e. No special payments shall be made for any insurance policies that Contractor and Subcontractors are required to carry because all are included in the Contract Sum.

f. The Owner as fiduciary shall have power to adjust and settle any loss with insurers.

12. Standard of Care. Contractor warrants that all services to be performed under this contract, if any, will be performed in a good and workmanlike manner with the professional skill and care ordinarily provided by competent Contractor providing similar services practicing in Bexar County, Texas and under the same or similar circumstances and license, if any, and that such services will be performed as expeditiously as is prudent considering the ordinary skill and care of a competent Contractor. Contractor warrants and represents that it will perform the Work for the Project in compliance with all applicable national, federal, state, and local, laws, regulations, codes, ordinances and orders (collectively, the "Applicable Laws") and manufacturer specifications.

13. Warranty. The Contractor warrants to the Owner that materials and equipment furnished under the Contract will be of good quality and new unless the Contract Documents require or permit otherwise. To the extent any of the materials or equipment purchased and installed by Contractor or any of its subcontractors have independent warranties or guarantees from the manufacturers of same, as a condition to receiving Final Payment Contractor shall pass through and assign all such warranties or guarantees to Owner to the extent they are assignable and (i) inform the warranting company in writing that Owner is the beneficiary of the warranty or guarantee and (ii) obtain a written acknowledgment from the warranting company that Owner is the beneficiary of the warranty or guarantee. The Contractor further warrants that the Work will be free from fault and defects and suitable for the purposes for which they were installed. All material shall be installed in a true and straight alignment, level and plumb; patterns shall be uniform; and jointing of materials shall be flush and level, unless otherwise directed in writing by the Architect. Work, materials, or equipment not conforming to these requirements may be considered defective. The Contractor further warrants to the Owner that the work will be performed in accordance with the



aforementioned Standard of Care, and in compliance with all Applicable Laws and in accordance with the drawings, plans and specifications. If there is any breach of this Agreement or warranty, Contractor shall remedy the matter, at its sole expense, to Owners sole satisfaction. If Contractor does not promptly remedy the matter, Owner may have the defective work or materials corrected and all direct and indirect costs of the correction shall be paid by Contractor. Such warranty shall extend for a period of two (2) years following final payment by the Owner or if a latent defect, within two (2) year after discovery thereof by Owner, except a longer warranty time shall control if it is specifically called for in the Contract Documents or provided by law.

14. Termination for Cause. If the Contractor fails to fulfill in a timely and proper manner its obligations under this Agreement, or if the Contractor violates any of the covenants, conditions, agreements, or stipulations of this Agreement, the Owner shall have the right to terminate this Agreement by giving written notice to the Contractor of such termination and specifying the effective date thereof. In the event of termination for cause, all finished or unfinished documents, data, studies, surveys, drawings, maps, models, photographs and reports prepared by the Contractor pursuant to this Agreement shall be turned over to the Owner and become the property of the Owner.

Notwithstanding the above, the Contractor shall not be relieved of liability to the Owner for damages sustained by the Owner by virtue of any breach of contract by the Contractor, and the Owner may set-off the damages it incurred as a result of the Contractor's breach of contract from any amounts it might otherwise owe the Contractor. Contractor shall not be entitled to any claim or claim of lien against Owner for any additional compensation or damages in the event of such termination.

15. Termination for Convenience of the Owner. Owner may at any time and for any reason terminate Contractor's services and work at Owner's convenience upon providing written notice to the Contractor specifying the extent of termination and the effective date. Upon receipt of such notice, Contractor shall, unless the notice directs otherwise, immediately discontinue the work and placing of orders for materials, facilities and supplies in connection with the performance of this Agreement.

Upon such termination, the Contractor shall be entitled to receive reasonable compensation for any necessary services actually and satisfactorily performed prior to the date of termination. Contractor shall not be entitled to any claim or claim of lien against Owner for any additional compensation or damages in the event of such termination and payment.

16. Termination. In the event of a termination for cause or convenience, Contractor shall (i) stop all work to the extent specified; (ii) place no future orders; (iii) terminate all orders and subcontracts to the extent of the termination; (iv) transfer title and deliver to Owner Work in process, completed Work, supplies, equipment, and materials produced as a part of, or acquired in connection with, the performance of the Work so terminated; (v) take such action as may be necessary for the protection and preservation of the materials and equipment related to this Agreement which is in the possession of Contractor and in which Owner has or may acquire an interest; (vi) assign to Owner and deliver all warranties and

guaranties as set forth herein and all plans and specifications, working drawings, etc., as set forth herein; and (vii) take any other action as reasonably required by Owner.

17. Suspension. The Owner may, without cause, order the Contractor in writing to suspend, delay or interrupt the Work in whole or in part for such period of time as the Owner may determine. During the period of suspension, Contractor shall protect and care for the Work. Contractor shall not be entitled to any claim or damages against Owner for any additional compensation due to the suspension; however, Contractor may make a request for additional time.

18. Changes in the Work. The Owner may, from time to time, request changes in the Work the Contractor will perform under this Agreement consisting of additions, deletions or other revisions. Contractor shall cooperate with Owner in good faith to make said adjustments. Contractor stipulates that acceptance of a Change Order by the Contractor constitutes full accord and satisfaction for any and all Claims, whether direct or indirect, including but not limited to impact, delay or acceleration damages, arising from the subject matter of the Change Order. The total of all Change Orders or other Changes in the Work may not increase the Contract Sum by more than 25% of the original Contract Sum. If there is a change order, the adjustment shall be based on one of the following methods: (i) mutual acceptance of a lump sum properly itemized and supported by sufficient substantiating data to permit evaluation; (ii) unit prices stated in the Contract Documents or subsequently agreed upon (excluding additional mark-ups for overhead, profit and fees will not be allowed) or (iii) if the Contractor does not respond promptly or disagrees with the method for adjustment in the Contract Sum, then the adjustment shall be determined by the Owner on the basis of the amount by which the Contractor's actual direct costs (labor, materials, rentals, bonds and insurance) have actually been increased over the direct cost of performing the Work without the Change in the Work.

19. Personnel.

a. The Contractor represents that he/she/it has, or will secure at its own expense, all personnel required in performing the services under this Agreement. Such personnel shall not be employees of or have any contractual relationship with the Owner.

b. All of the services required hereunder will be performed by the Contractor or under its supervision and all personnel engaged in the work shall be fully qualified and shall be authorized or permitted under State and Local law to perform such services.

c. None of the work or services covered by this Agreement shall be subcontracted without the prior written approval of the Owner. Any work or services subcontracted hereunder shall be specified by written contract or agreement and shall be subject to each provision of this Agreement.

20. Compliance with Local Laws. The Contractor shall comply with all Applicable Laws and the Contractor shall save the Owner harmless with respect to any damages arising from any tort done in performing any of the work under this Agreement.

21. Permits, Fees, Notices and Compliance with Laws. If laws, ordinances, or any public authority require any of the Work to be specifically tested, inspected, or approved, Contractor shall arrange for same and give Owner's Representative timely notice of its readiness for testing or inspection and of the date fixed for such testing or inspection. The Contractor shall also be responsible for: (i) securing all permits and licenses necessary for the accomplishment of the Work and (ii) making and submitting applications for the building permit. Upon notice from the Contractor, the Owner shall pay the municipality directly for the building permit and all other development "impact" fees, if any. Upon notice from the Contractor, the Owner shall also be responsible for payment of other permits, governmental fees, licenses, and inspections related to said governmental permits, fees or licenses, necessary for proper execution of the Contract and which are legally required. Such fees and expenses shall only be reimbursable to Contractor if expressly agreed to in writing by Owner and without any markup. Contractor shall be responsible for the following: fees related to Contractor's failure to comply with the Contract Documents, federal law, state law, local law or manufacturer's instructions; re-inspection fees and charges for failed or missed inspections; fines, assessments, penalties or charges related to some form of violation; correction of Contractor's work; damage caused by Contractor to utilities or other property owned or controlled by a governmental entity; temporary storm and drain connections; hazardous materials; or other fees not mentioned in this paragraph.

22. Conflicts of interest.

a. Board of Trustees. No member of the Owner's Board of Trustees and no other officer, employee, or agent of the Owner, who exercises any functions or responsibilities in connection with administration, construction, engineering, or implementation of the Agreement shall have any personal financial interest, direct or indirect, in the Contractor or this Agreement; and the Contractor shall take appropriate steps to assure compliance.

b. Contractor and Employees. The Contractor warrants and represents that it has no conflict of interest associated with the Owner of this Agreement. The Contractor further agrees that it will not employ an individual with a conflict of interest as described herein

23. Damages or Delays Caused by Owner. Contractor must advise Owner in writing within two (2) business days of any acts or omissions of Owner or Architect causing any damages or delays to Contractor, and Contractor must within ten (10) calendar days thereof give Owner's Representative, and Architect, if any, a detailed written statement describing the nature of the alleged cause, the amount of damages and/or the period of delay so caused. Otherwise, such claims shall not result in either compensation or an extension of the Completion Date. The Architect will promptly investigate such Claim and report findings and a recommended resolution in writing to the Owner and Contractor. If Owner elects, in its sole discretion, it may authorize an extension of time or additional compensation; however, any additional compensation shall not exceed the total amount of the contingencies provided for in the Agreement, if any.

24. Damages or Delays Caused by Contractor. Contractor will, at its own expense, repair or cause to be repaired any damage to Owner's property, other than that necessary for the proper execution of the Work, caused by Contractor or any of its subcontractors or materialmen.

25. Payment of Prevailing Wage Rates; Certified Payrolls.

The Contractor and Contractor's Subcontractors shall cause all persons performing work on the Project to be properly classified by reference to, and be paid fully in compliance with, Chapter 2258 of the Texas Government Code, as that Chapter may be amended or recodified from time to time (current statute attached as EXHIBIT A-1), and the wage and hour payment and payroll reporting requirements of the federal Davis Bacon and Related Acts, as those Acts may be amended or recodified from time to time (DBRA), adopted by Alamo Colleges to comply with Chapter 2258 according to the Davis-Bacon Wage Rate Determinations published at the website of the federal Department of Labor applicable to this Agreement ("Applicable State Requirements").

Any agreement involving any use of federal funds within the meaning of DBRA would require the Contractor and Contractor's Subcontractors to fully comply with (i) ALL DBRA requirements (current version attached as EXHIBIT A-2), which exceed those required by Alamo Colleges' DBRA requirements adopted for compliance with Chapter 2258 by, without limitation, requiring the posting of federally required notices at the jobsite ("Notice Requirements"), and (ii) the Copeland "Anti-Kickback" Act (collectively, "Applicable Federal Requirements").

Contractor and Contractor's Subcontractors shall apply BOTH the Applicable Federal Requirements and the Applicable State Requirements in the performance of this Agreement, without regard for whether or not the Applicable Federal Requirements would otherwise apply to the Work.

The wage rates listed in EXHIBIT A-3 below have been ascertained and determined by the Owner as the Davis-Bacon Wage Rate Determinations published at the website of the federal Department of Labor applicable to this Agreement for the classifications listed. The value of prevailing fringe benefits must be included in the total compensation wage rate. The Contractor and each subcontractor shall compensate all laborers, workmen and mechanics employed by them in the execution of this contract not less than such rates for each craft or type or workman or mechanic needed to execute the contract. In the event the prescribed wages are not in compliance with BOTH the Applicable Federal Requirements and the Applicable State Requirements, then both such requirements shall prevail. In the event a conflict exists for the same classification between two different wage determinations, the Contractor and each subcontractor must pay compensation at the higher rate. This determination of prevailing wages shall not be construed to prohibit the payment of more than the rates listed. Nothing contained in this paragraph shall create any claim or cause of actions by such laborer, workman or mechanic against the District for wages payable by the Contractor or any subcontractor.

Without limitation, Contractor shall at least weekly send a reliable representative to the Project job site to digitally photograph with imprinted date and time notation, and

promptly send a duplicate thereof to Alamo Colleges' Associate Vice-Chancellor for Facilities or designee, the required notice statement set forth in EXHIBIT A-4 as evidence of compliance, by posting, with the Notice Requirements.

The Contractor and Contractor's Subcontractors shall prepare and submit weekly certified payroll reports to the Owner or designated Owner's agent for each week that work is performed. The reports shall attest that laborers and mechanics were paid prevailing wages and fringe benefits in accordance with the Applicable Construction Requirements. The reports shall be submitted on U.S. Department of Labor (DOL) Form WH-347 or equivalent.

The Contractor and Contractor's Subcontractors shall each be provided access to Alamo Colleges' LCP Tracker Wage and Hour Compliance Software for submission of the reports. A representative of the Contractor and each of the Contractor's Subcontractors shall be trained in use of the LCP Tracker Software and submission of the reports.

26. Anti-Kickback Provisions.

No person employed in the construction, renovation or repair of any Owner project shall be induced, by any means, to give up to any Contractor, subcontractor, public official, or any other employee of the Owner part of the compensation to which he is otherwise entitled.

No employee of the Owner, or the Architect/Engineer who is authorized on behalf of the Owner to negotiate, make, accept, or approve or participate in negotiating any architectural, engineering, insurance, inspection, contract, subcontract, change order, or material supply, purchase order/subcontract shall have any interest whatsoever or receive any compensation in connection with the aforementioned duties.

27. Owner Additional Right to Audit and Access Record.

In addition to the right provided elsewhere herein, Contractor's records, which shall include, but not be limited to, accounting records, written policies and procedures, subcontract files (including proposals of successful and unsuccessful offerors), original estimates, estimating worksheets, correspondence, change order files (including documentation covering negotiated settlements), and any other supporting evidence necessary to substantiate charges related to this contract (all of the foregoing hereinafter referred to as "records") shall be open to inspection and subject to audit and/or reproduction, during normal working hours, by Owner's agent or its authorized representative to the extent necessary to adequately permit evaluation and verification of any invoices, payments or claims submitted by the Contractor or any of his payees pursuant to the execution of the contract. Such records necessary to evaluate and verify direct and indirect costs (including overhead allocations) as they may apply to costs associated with this contract.

For the purpose of such audits, inspections, examinations and evaluations, the Owner's agent or authorized representative shall have access to said records from the

effective date of this contract, for the duration of the work, and until twelve (12) years after the day of final payment by Owner to Contractor pursuant to this contract.

Owner's agent or its authorized representative shall have access to the Contractor's facilities, shall have access to all necessary records, and shall be provided adequate and appropriate work space, in order to conduct audits in compliance with this article. Owner's agent or its authorized representative shall give auditees reasonable advance notice of intended audits.

Contractor shall require all subcontractors, insurance agents, and material suppliers (payees) to comply with the provisions of this article by insertion of the requirements hereof in a written contract agreement between the Contractor and payee. Failure to obtain such written contracts which include such provisions shall be reason to exclude some or all of the related payees' costs from amounts payable to the Contractor pursuant to this contract.

#### 28. Criminal Background Checks.

Contractor shall obtain all criminal history information required by Texas Education Code Chapter 22 regarding its "covered employees," as defined below. If Contractor is required by Chapter 22 to obtain the information from the Fingerprint-based Applicant Clearinghouse of Texas, then Contractor will also subscribe to that person's criminal history record information. Before beginning any Work on the Project, Contractor will provide written certification to the Owner that Contractor has complied with the statutory requirements as of that date. Upon request by Owner, Contractor will provide, in writing: updated certifications and the names and any other requested information regarding covered employees, so that the Owner may obtain criminal history record information on the covered employees. Contractor shall assume all expenses associated with obtaining criminal history record information.

Contractor will not assign any "covered employee" with a "disqualifying criminal history," as those terms are defined below, to work on the Project. If Contractor receives information that a covered employee has a reported disqualifying criminal history, then Contractor will immediately remove the covered employee from the Project and notify the Owner in writing within three (3) work days. If the Owner objects to the assignment of any covered employee based on the basis of the covered employee's criminal history record information, the Contractor agrees to discontinue using that covered employee to provide services on Owner's Project. If Contractor has taken precautions or imposed conditions to ensure that the employees of Contractor and any subcontractor will not become covered employees, Contractor will ensure that these precautions or conditions continue throughout the time the contracted services are provided.

For the purposes of this Section, "covered employees" means employees, agents or applicants of Contractor who has or will have continuing duties related to the services to be performed on Owner's Project and has or will have direct contact with Owner's students. The Owner will decide what constitutes direct contact with Owner's students. "Disqualifying criminal history" means: any conviction or other criminal history information designated by the Owner; any felony or misdemeanor conviction that would disqualify a person from obtaining educator certification under Texas Education Code Section 21.060 and 19 Texas

Administrative Code §249.16; or one of the following offenses, if at the time of the offense, the victim was under 18 years of age or enrolled in a public school; a felony offense under the Texas Penal Code Title 5 Offense Against Persons; an offense for which a defendant is required to register as a sex offender under Texas Code of Criminal Procedure Chapter 62; or an equivalent offense under federal law or the laws of another state.

Subcontractors or any subcontractor entity, as defined by Texas Education Code §22.0834(p)(2), shall be required by the terms of their contract with Contractor or any other contracting entity (as defined in Texas education Code §22.0834(p)(1), and by Texas Law, to obtain the required criminal history record information on their employees, agents, or applicants, to give required certifications to Owner and the contracting entities, and to obtain required certifications from the subcontracting entity's subcontractors.

On request of Owner, Contractor shall provide all necessary identifying information to allow Owner to obtain criminal history record information for covered employees of the Contractor and all subcontractors, Contractor shall update this list on Owner's request. In addition, the Contractor shall maintain all records of such finger printing and background checks through the DPS and make such available to the Owner within seventy-two (72) hours of request by the Owner.

In addition, Contractor will at least annually obtain criminal history record information that relates to any employee, agent, or applicant of the Contractor, if the person has or will have duties related to the Project, and the duties are or will be performed on Owner's Project, or at any other location where students are likely to be present. Contractor shall assume all expenses associated with the background checks and shall immediately remove any employee, agent or subcontractor who was convicted of a felony or a misdemeanor involving moral turpitude from Owner's property, or other location where students are likely to be present. Owner shall determine what constitutes "moral turpitude" or a "location where students are likely to be present."

In addition, for each employee prior to commencing any work, Construction Manager and Subcontractors shall certify to the Owner all the information stated in the Owner's Criminal Background Check Certification Form, which is attached hereto as EXHIBIT A-5. Said form shall be used for certification purposes; however, if no form is attached, Construction Manager shall use the form approved and provided by Owner.

## 29. Miscellaneous Provisions

a. Litigation. Notwithstanding any term of the Agreement to the contrary, Contractor may not terminate the Agreement solely as a result of Owner initiating litigation against the Contractor prior to completion of the Work

b. Successors and assigns. This Agreement shall be binding upon and inure to the benefit of the parties hereto and their respective heirs, executors, administrators, legal representatives, successors and assigns where permitted by this Agreement. However, Contractor may not assign this Agreement or transfer an interest in this Agreement without the prior written consent of the Owner by and through its Authorized Representative.

c. Subcontractors. Owner shall be notified in writing of the name of any proposed subcontractor and approve or disapprove of the same, prior to the subcontractor performing any work. Contractor agrees to bind every subcontractor to the terms of this Agreement. Owner is permitted to communicate directly with subcontractors; however, Owner may not direct the Work of Contractor's subcontractors, without Contractor's written consent.

d. Severability. In any case one or more of the provisions contained in this Agreement shall for any reason be held to be invalid, illegal or unenforceable in any respect, such invalidity, illegality, or unenforceability shall not affect any other provision thereof and this Agreement shall be construed as if such invalid, illegal, or unenforceable provision had never been contained herein.

e. Intent of Contract Documents. Should any conflict be found in or between the Contract Documents, the Contractor shall be deemed to have estimated the Work on the basis of the greater quantity or better quality, or the most stringent requirement, unless he shall have obtained an interpretation in writing from the Architect as to what shall govern before the submission of his Proposal. The Architect, in case of such conflict, may interpret or construe the documents so as to obtain the most substantial and complete performance of the Work consistent with the Contract Documents and reasonably inferable therefrom, in the best interest of Owner, and the Architect's interpretation shall be final.

f. Reports and Information. The Contractor, at such times and in such forms as the Owner may require, shall furnish the Owner such periodic reports as it may request pertaining to the work or services undertaken pursuant to this Agreement, the costs and obligations incurred or to be incurred in connection therewith, and any other matters covered by this Agreement.

g. Attorney Fees. If any action at law or in equity is necessary to enforce or interpret the terms of this Agreement, the prevailing party shall be entitled to reasonable attorney's fees, costs, and necessary disbursements in addition to any other relief to which such party may be entitled.

h. Amendment. This Agreement may be amended by a written mutual agreement of the parties signed by the Contractor, authorized by the Owner and signed by the Owners' authorized representative.

i. Prohibition on Contracts with Certain Companies. The Contractor affirmatively warrants and represents that it is not (i) an organization designated as a foreign terrorist organization by the United States Secretary of State, as authorized by 8 U.S.C. Section 1189 (ii) a company that is identified on a list prepared and maintained by the Texas Comptroller under Tex. Gov't Code § 2252.153 (iii) a company that has contracts with or provides supplies or services to Iran, Sudan or a foreign terrorist organization (iv) prohibited from contracting with the District, as provided in Tex. Gov't Code §§ 2252.151 *et seq.* (v) boycotting Israel and will not boycott Israel during the term of the Agreement (vi) going to allow any iron or steel produced through a



manufacturing process and used in the Project to be produced in any country other than the United States unless the Owner has determined otherwise.

j. Payments. Notwithstanding anything appearing elsewhere to the contrary, Owner is authorized to make payments only as provided by applicable statute, Texas Government Code Section 2251.021(b), the provisions of which (essentially net 45 days) shall override any contrary language. Any interest on overdue amounts shall not exceed the rate(s) established by Section 2251.025 of the Texas Government Code.

k. Owner Revenues. Owner commits only its current revenues hereunder, as required by Texas law. The Owner retains the continuing right to terminate the Agreement without liability for said termination at the expiration of each budget period during the term of this Agreement. The Owner will make best efforts to obtain and appropriate funds to meet Owner's obligations under the Agreement, consistent with the maintenance of reasonable reserves.

l. Arbitration, Limitations, Disclaimers, and Waivers. Notwithstanding anything appearing elsewhere to the contrary, the Agreement is modified to delete: (a) any requirement of mandatory arbitration; (b) any reduction in the applicable statute of limitations or statute of repose; (c) any waiver, release or discharge of a right, obligation, remedy or claim belonging to the Owner; (d) any assumption of the risk by the Owner; (e) any disclaimers of implied or express warranties by Contractor; and (f) any limitations of liability for the benefit of the Contractor. If there is a dispute, the parties may first attempt to resolve the dispute in mediation in Bexar County, Texas and if that fails, the parties may resort to litigation. However, the parties agree to waive their right to a jury trial.

m. Waiver. The failure of Owner to insist upon strict performance of any of the terms, conditions, and provisions of this Agreement shall not be deemed a waiver of future compliance therewith by the party by which the same is required to be performed hereunder and shall in no way prejudice the remaining provisions of this Agreement.

n. Copyright. No report, maps, or other documents produced in whole or in part under this Agreement shall be the subject of an application for copyright by or on behalf of the Contractor and shall be considered a Work for Hire assigned hereunder to Owner. The Contractor shall pay all royalties and license fees and they shall not be included in Cost of Work. **THE CONTRACTOR SHALL DEFEND SUITS OR CLAIMS FOR INFRINGEMENT OF COPYRIGHTS AND PATENT RIGHTS, SHALL WAIVE AND RELEASE CLAIMS AGAINST THE OWNER AND ARCHITECT, AND SHALL INDEMNIFY AND HOLD HARMLESS THE OWNER AND ARCHITECT FROM LOSS ON ACCOUNT THEREOF, PROVIDED, HOWEVER, CONTRACTOR SHALL NOT BE RESPONSIBLE TO ARCHITECT FOR SUCH DEFENSE OR LOSS WHEN A PARTICULAR DESIGN, PROCESS OR PRODUCT OF A PARTICULAR MANUFACTURER OR MANUFACTURERS IS REQUIRED BY THE CONTRACT DOCUMENTS, OR WHERE THE COPYRIGHT VIOLATIONS ARE CONTAINED IN DRAWINGS, SPECIFICATIONS**

**OR OTHER DOCUMENTS PREPARED BY THE ARCHITECT, AND SHALL NOT BE RESPONSIBLE TO OWNER IF OWNER REQUIRES A PARTICULAR DESIGN, PROCESS OR PRODUCT THAT CONSTITUTES A COPYRIGHT VIOLATION.** However, if the Contractor has reason to believe that the required design, process or product is an infringement of a copyright or a patent, the Contractor shall be responsible for such loss unless such information is promptly furnished to the Owner and Architect in writing.

**o. Limitation of Liability. THE LIMIT OF LIABILITY OF OWNER TO CONTRACTOR FOR ANY CAUSE OR COMBINATION OF CAUSES SHALL BE LIMITED TO THE TOTAL AMOUNT OF FEES PAID BY OWNER TO CONTRACTOR UNDER THIS AGREEMENT.**

p. Representations. No representation, warranty, or covenant made to Owner in this Agreement nor any document, certificate, exhibit, or other information given or delivered to Owner pursuant to this Agreement or in response to the Owner's request for services or proposal contains or will contain any untrue statement of a material fact, or omits or will omit a material fact necessary to make the statements contained in this Agreement or the matters disclosed in the related documents, certificates, information, or exhibits not misleading.

q. Cleaning. Contractor shall at all times keep the Work site free from accumulations of waste material or rubbish. At the completion of the Work, it shall remove all of its tools, scaffolding, and surplus materials and shall leave the Work site "broom clean" or its equivalent.

r. Trenching. Contractor shall bear responsibility for the cost, design and execution of acceptable trenching and shoring procedures, in accordance with Texas Health and Safety Code, Subchapter C, Sections 756.021, et seq., as amended. Trench excavation safety protection shall be a separate pay item, and shall be based on linear feet of trench excavated. Special shoring requirements shall also be a separate pay item, and shall be based on the square feet of shoring used. To the extent that any portion of the Work requires a trench excavation exceeding five (5) feet in depth, in accordance with Texas Health and Safety Code Section 756.023(a), Contractor shall fully comply, and shall require any applicable subcontractor to comply, with:

- i. The Occupational Safety and Health Administration standards for trench safety in effect for the Construction of the Work.
- ii. The special shoring requirements, if any, of the Owner and shall also take reasonable precautions in response to any geotechnical information obtained by Owner for use by the Contractor in the design of the trench safety system.

s. Risk of Loss. Contractor shall continuously protect all materials and equipment to used or to be used in the Work or Project from damage or loss including the materials and equipment, which are installed in, on, or about the Project. The risk of loss or damage to any such materials or equipment due to fire, theft, vandalism, or any other cause whatsoever shall remain with and be borne by Contractor.

However, title and risk of loss or damage to materials and equipment shall pass to Owner at the time of Final Payment.

t. No Third Party Beneficiary. This Agreement is for the sole benefit of the parties hereto and nothing herein shall create, give or be construed to give any third party any legal or equitable claim or right of action. There are no third party beneficiaries to the Agreement.

u. Further Assurances. The Parties will do, execute and deliver, or will cause to be done, executed and delivered, all such further acts, documents (including certificates, declarations, affidavits, reports and opinions) and things as the other may reasonably request for the purpose of giving effect to the Agreement or for the purpose of establishing compliance with the representations and obligations of the Agreement.

v. Cooperation. The Owner reserves the right to let other contracts in connection with this Work or work related thereto and Contractor shall cooperate with all other contractors and shall properly coordinate its Work with theirs. Contractor shall cooperate fully with Owner in performing the Work to be done hereunder and shall not interfere with Owner's operations.

w. Jurisdiction and Venue. The parties agree that this Agreement and any amendments thereto shall be governed by Texas law. Notwithstanding anything appearing elsewhere to the contrary, all questions of Owner powers, privileges and immunities (including immunity from suit and damages), choice of law, limitations periods, access to courts and liability for attorney's fees shall be governed by the internal laws and regulations of the State of Texas, and none of such shall be deemed waived by reason of execution of the Agreement. The parties hereby agree and stipulate to the jurisdiction and venue of the courts of competent jurisdiction of Bexar County, Texas or the United States District Courts for the Western District of Texas for any matter related to the Agreement.

x. Counterparts. To facilitate execution, this Agreement and any addendum may be executed in as many counterparts as may be convenient or required. It shall not be necessary that the signature of, or on behalf of, each party, or that the signature of all persons required to bind any party, appear on each counterpart. All counterparts shall collectively constitute a single instrument. It shall not be necessary in making proof of this instrument to produce or account for more than a single counterpart containing the respective signatures of, or on behalf of, each of the parties hereto. Any signature page to any counterpart may be detached from such counterpart without impairing the legal effect of the signatures thereon and thereafter attached to another counterpart identical thereto except having attached to it additional signature pages.

y. Compliance with Certain Laws. Contractor warrants and represents that it is aware of, is fully informed about, is in full compliance with, and will comply with its obligations under existing Applicable Laws and regulations, including but not limited to Title VI of the Civil Rights Act of 1964, as amended (42 USC 2000(D)), Equal

Employment Opportunity (Executive Order 11246), as amended (41 CFR 60-1 and 60-2), Vietnam Era Veterans Readjustment Act of 1974, as amended (41 CFR 60-250), Rehabilitation Act of 1973, as amended (41 CFR 60-741), Age Discrimination Act of 1975 (42 USC 6101 et seq.), Non-segregated Facilities (41 CFR 60-1), Omnibus Budget Reconciliation Provision, Section 952, Fair Labor Standards Act of 1938, Sections 6, 7, and 12, as amended, Immigration Reform and Control Act of 1986, and Utilization of Small Business Concerns and Small Business Concerns Owned and Controlled by Socially and Economically Disadvantaged Individuals (PL 96-507), the Americans with Disabilities Act of 1990 (42 USC 12101 et seq.), the Civil Rights Act of 1991, Byrd Anti-Lobbying Amendment (31 USC 1352), Copeland "Anti-Kickback" Act (40 USC 3145), Contract Work Hours and Safety Standards Act (40 USC 3701 et seq.), and all laws and regulations and executive orders as are applicable.

z. Survival Clause. The indemnity, insurance and warranty obligations of the Contractor under the Agreement shall survive the expiration or termination of the Agreement.

aa. Incorporation of Whereas clauses. The WHEREAS clauses set forth above are incorporated into the terms of this Agreement, as if fully set forth herein, and they are intended to be used to construe the terms of this Agreement.

bb. Bonds. For any contract in excess of \$50,000.00 or upon Owner's written request and prior to commencement of the Work, Contractor shall provide a payment and performance bond in the amount of the Agreement to the Owner and in a form acceptable to the Owner.

cc. Independent Contractor. Contractor is an independent Contractor and not an employee or agent of the Company and has no power to bind the Company in any way.

dd. Governmental Functions. Contractor acknowledges and stipulates that this Agreement and the Work and Project covered by this Agreement are part of the governmental functions of the District.

**30. Liquidated Damages. IT IS SPECIFICALLY UNDERSTOOD AND AGREED BY AND BETWEEN OWNER AND CONTRACTOR THAT TIME IS OF THE ESSENCE IN THE SUBSTANTIAL COMPLETION AND FINAL COMPLETION OF THE PROJECT AND OWNER SHALL SUSTAIN ACTUAL AND DIRECT DAMAGES AS A RESULT OF CONTRACTOR'S FAILURE, NEGLIGENCE OR REFUSAL TO ACHIEVE SAID DEADLINES. SUCH ACTUAL AND DIRECT DAMAGES ARE, AND WILL CONTINUE TO BE, IMPRACTICABLE AND EXTREMELY DIFFICULT TO DETERMINE. EXECUTION OF THIS AGREEMENT UNDER THESE SPECIFICATIONS SHALL CONSTITUTE AN AGREEMENT BY OWNER AND CONTRACTOR THAT THE AMOUNTS STATED BELOW ARE THE ESTIMATED MINIMUM VALUE OF THE COSTS AND ACTUAL AND DIRECT DAMAGES CAUSED BY FAILURE OF CONTRACTOR TO SUBSTANTIALLY COMPLETE THE WORK WITHIN THE ALLOTTED TIMES, THAT SUCH SUMS ARE LIQUIDATED DIRECT DAMAGES AND**

SHALL NOT BE CONSTRUED AS A PENALTY, AND THAT SUCH SUMS MAY BE DEDUCTED FROM PAYMENTS DUE CONTRACTOR IF SUCH DELAY OCCURS. IT IS EXPRESSLY UNDERSTOOD THAT THE SAID SUM PER DAY IS AGREED UPON AS A FAIR ESTIMATE OF THE PECUNIARY DAMAGES WHICH WILL BE SUSTAINED BY THE OWNER IN THE EVENT THAT THE WORK IS NOT COMPLETED WITHIN THE AGREED TIME, OR WITHIN THE AGREED EXTENDED TIME, IF ANY, OTHERWISE PROVIDED FOR HEREIN. SAID SUM SHALL BE CONSIDERED AS LIQUIDATED DAMAGES ONLY AND IN NO SENSE SHALL BE CONSIDERED A PENALTY, SAID DAMAGES BEING CAUSED BY, BUT NOT LIMITED TO, ADDITIONAL COMPENSATION FOR PERSONNEL, ATTORNEYS FEES, ARCHITECTURAL FEES, ENGINEERING FEES, PROGRAM MANAGEMENT FEES, INSPECTION FEES, STORAGE COSTS, FOOD SERVICE COSTS, TRANSPORTATION COSTS, UTILITIES COSTS, COSTS OF TEMPORARY FACILITIES, LOSS OF INTEREST ON MONEY, AND OTHER MISCELLANEOUS INCREASED COSTS, ALL OF WHICH ARE DIFFICULT TO EXACTLY ASCERTAIN. FAILURE TO COMPLETE THE WORK WITHIN THE DESIGNATED OR AGREED EXTENDED DATES OF SUBSTANTIAL OR FINAL COMPLETION, SHALL BE CONSTRUED AS A BREACH OF THIS AGREEMENT.

31. IT IS EXPRESSLY AGREED AS A PART OF THE CONSIDERATION INDUCING THE OWNER TO EXECUTE THIS AGREEMENT THAT THE OWNER MAY DEDUCT FROM THE FINAL PAYMENT MADE TO THE CONTRACTOR A SUM EQUAL TO \$ \_\_\_\_\_ PER DAY FOR EACH AND EVERY ADDITIONAL CALENDAR DAY BEYOND THE AGREED DATE OF SUBSTANTIAL COMPLETION.

32. TIMELY FINAL COMPLETION IS AN ESSENTIAL CONDITION OF THIS AGREEMENT. CONTRACTOR AGREES TO ACHIEVE FINAL COMPLETION OF THE AGREEMENT WITHIN 30 DAYS OF THE DESIGNATED OR EXTENDED DATE OF SUBSTANTIAL COMPLETION. OWNER AND CONTRACTOR AGREE THAT SHOULD CONTRACTOR FAIL TO ACHIEVE FINAL COMPLETION OF THE AGREEMENT BY THE DEADLINE, OWNER SHALL CONTINUE TO BE DAMAGED TO A GREATER DEGREE BY SUCH DELAY. CONTRACTOR AND OWNER AGREE THAT THE AMOUNT OF LIQUIDATED DAMAGES FOR EACH CALENDAR DAY FINAL COMPLETION IS DELAYED BEYOND THE DATE SET FOR FINAL COMPLETION SHALL BE THE SUM OF \$ \_\_\_\_\_ PER DAY. OWNER MAY DEDUCT FROM THE FINAL PAYMENT MADE TO CONTRACTOR, OR, IF SUFFICIENT FUNDS ARE NOT AVAILABLE, THEN CONSTRUCTION MANAGER SHALL PAY OWNER THE AMOUNTS SPECIFIED PER DAY FOR EACH AND EVERY CALENDAR DAY THE BREACH CONTINUES AFTER THE DEADLINE FOR FINAL COMPLETION OF THE WORK.

33. Extent of Agreement - This Agreement includes: **Parts I-III** attached hereto; **Exhibit A** attached hereto; other exhibits attached hereto at **Exhibit B** including the request for proposal and Contractor's response thereto, if any and if attached hereto; and any subsequent written agreements signed by both parties and approved by the governing body, if necessary. The Contract Documents include this Agreement, the attachments and the incorporated matters, which represents the entire and integrated agreement between the Owner and the Contractor and supersedes all prior negotiations,

representations or agreements, either written or oral. Moreover, this Agreement and its attachments shall prevail over any conflicting provisions in the request for proposal or Contractor's Response thereto. To be effective, all Contract Documents requiring signatures must be signed first by the Contractor and then by the Owner's Authorized Representative.

#### 34. EDA Grant Requirements for contractor and Subcontractors

This Project is funded in whole or in part by a grant from the Economic Development Administration (EDA) of the U.S. Department of Commerce. The Contractor is required to comply with all of the following requirements, and where applicable, to require its subcontractors and their sub-subcontractors and suppliers to comply with them.

It is the sole obligation of the Contractor to discuss these requirements with the Contractor's legal counsel or other consultant so that the Contractor fully understands the requirements and obligations imposed by these provisions.

The Contractor will not be relieved from liability for failure to comply with the statutory requirements by virtue of any description of the obligations set forth in this Agreement or in the solicitations documents.

The obligations set forth in this Section 34, including any record-keeping and reporting requirements prescribed by the statutes, are in addition to all other obligations imposed in this Agreement and the Contract Documents.

a. Anti-Lobbying Certification - No federal funds may be used to pay any person or organization for influencing or attempting to influence an officer or employee of any agency, a member of Congress, officer or employee of Congress, or an employee of a member of Congress in connection with obtaining any Federal contract, grant or any other award. The Contractor must sign an Anti-Lobbying Certification in the form attached as Appendix H of the CSP Documents and must require each subcontractor or supplier whose contract exceeds \$100,000 to sign an Anti-Lobbying Certification, copies of which must be provided to Alamo Colleges District.

b. Equal Employment Opportunity Act - Except as otherwise provided under 41 CFR Part 60, all contracts that meet the definition of "federally assisted construction contract" in 41 CFR Part 60-1.3 must include the equal opportunity clause provided under 41 CFR 60-1.4(b), in accordance with Executive Order 11246, "Equal Employment Opportunity" (30 FR 12319, 12935, 3 CFR Part, 1964-1965 Comp., p. 339), as amended by Executive Order 11375, "Amending Executive Order 11246 Relating to Equal Employment Opportunity," and implementing regulations at 41 CFR part 60, "Office of Federal Contract Compliance Programs, Equal Employment Opportunity, Department of Labor."

The Contractor must comply with the following provisions, which will be set out in the Contract:

During the performance of the contract, the Contractor agrees as follows:

(1) The contractor will not discriminate against any employee or applicant for employment because of race, color, religion, sex, sexual orientation, gender identity, or national origin. The contractor will take affirmative action to ensure that applicants are employed, and that employees are treated during employment without regard to their race, color, religion, sex, sexual orientation, gender identity, or national origin. Such action shall include, but not be limited to the following:

Employment, upgrading, demotion, or transfer; recruitment or recruitment advertising; layoff or termination; rates of pay or other forms of compensation; and selection for training, including apprenticeship. The contractor agrees to post in conspicuous places, available to employees and applicants for employment, notices to be provided setting forth the provisions of this nondiscrimination clause.

(2) The contractor will, in all solicitations or advertisements for employees placed by or on behalf of the contractor, state that all qualified applicants will receive consideration for employment without regard to race, color, religion, sex, sexual orientation, gender identity, or national origin.

(3) The contractor will not discharge or in any other manner discriminate against any employee or applicant for employment because such employee or applicant has inquired about, discussed, or disclosed the compensation of the employee or applicant or another employee or applicant. This provision shall not apply to instances in which an employee who has access to the compensation information of other employees or applicants as a part of such employee's essential job functions discloses the compensation of such other employees or applicants to individuals who do not otherwise have access to such information, unless such disclosure is in response to a formal complaint or charge, in furtherance of an investigation, proceeding, hearing, or action, including an investigation conducted by the employer, or is consistent with the contractor's legal duty to furnish information.

(4) The contractor will send to each labor union or representative of workers with which he has a collective bargaining agreement or other contract or understanding, a notice to be provided advising the said labor union or workers' representatives of the contractor's commitments under this section, and shall post copies of the notice in conspicuous places available to employees and applicants for employment.

(5) The contractor will comply with all provisions of Executive Order 11246 of September 24, 1965, and of the rules, regulations, and relevant orders of the Secretary of Labor.

(6) The contractor will furnish all information and reports required by Executive Order 11246 of September 24, 1965, and by rules, regulations, and orders of the Secretary of Labor, or pursuant thereto, and will permit access to his books, records, and accounts by the administering agency and the Secretary of Labor for purposes of investigation to ascertain compliance with such rules, regulations, and orders.

(7) In the event of the contractor's noncompliance with the nondiscrimination clauses of this contract or with any of the said rules, regulations, or orders, this contract may be canceled, terminated, or suspended in whole or in part and the contractor may be declared ineligible for further Government contracts or federally assisted construction contracts in accordance with procedures authorized in Executive Order 11246 of September 24, 1965, and such other sanctions may be imposed and remedies invoked as provided in Executive Order 11246 of September 24, 1965, or by rule, regulation, or order of the Secretary of Labor, or as otherwise provided by law.

(8) The contractor will include the portion of the sentence immediately preceding paragraph (1) and the provisions of paragraphs (1) through (8) in every subcontract or purchase order unless exempted by rules, regulations, or orders of the Secretary of Labor issued pursuant to section 204 of Executive Order 11246 of September 24, 1965, so that such provisions will be binding upon each subcontractor or vendor. The contractor will take such action with respect to any subcontract or purchase order as the EDA grant administrator may direct as a means of enforcing such provisions, including sanctions for noncompliance:

Provided, however, that in the event a contractor becomes involved in, or is threatened with, litigation with a subcontractor or vendor as a result of such direction by the grant administrator, the contractor may request the United States to enter into such litigation to protect the interests of the United States.

c) Affirmative Steps to Assure that Minority Businesses, Women's Business Enterprises, and Labor Surplus Area Firms are used.

The Contractor must also take all necessary affirmative steps to assure that minority businesses, women's business enterprises, and labor surplus area firms are used when possible. Affirmative steps must include:

(1) Placing qualified small and minority businesses and women's business enterprises on solicitation lists;

(2) Assuring that small and minority businesses, and women's business enterprises are solicited whenever they are potential sources;

(3) Dividing total requirements, when economically feasible, into smaller tasks or quantities to permit maximum participation by small and minority businesses, and women's business enterprises;



(4) Establishing delivery schedules, where the requirement permits, which encourage participation by small and minority businesses, and women's business enterprises;

(5) Using the services and assistance, as appropriate, of such organizations as the Small Business Administration and the Minority Business Development Agency of the Department of Commerce; and

(6) Requiring Subcontracts to take the affirmative steps listed in paragraphs (1) through (5) of this section.

d. Davis-Bacon Act - The Contractor and all subcontractors are required to comply with the Davis-Bacon Act (40 U.S.C. 3141-3144, and 3146-3148) as supplemented by Department of Labor regulations (29 CFR Part 5, "Labor Standards Provisions Applicable to Contracts Covering Federally Financed and Assisted Construction"), including, but not limited to the requirement to pay laborers and mechanics not less than the wage rates established by the U. S. Department of Labor for the County in which the Project is located, and to pay wages not less than once a week.

e. Copeland "Anti-Kickback" Act - The Contractor and all subcontractors must comply with the Copeland "Anti-Kickback" Act (40 U.S.C. 3145), as supplemented by Department of Labor regulations (29 CFR Part 3, "Contractors and Subcontractors on Public Building or Public Work Financed in Whole or in Part by Loans or Grants from the United States"). The Contractor and each subcontractor is prohibited from inducing, by any means, any person employed in the construction, completion, or repair of the Project, to give up any part of the compensation to which he or she is otherwise entitled.

f. Contract Work Hours and Safety Standards Act (40 U.S.C. 3701-3708) - For Contracts that are greater than \$100,000, the Contractor and all subcontractors are required to comply with 40 U.S.C. 3702 and 3704, as supplemented by Department of Labor regulations (29 CFR Part 5). Under 40 U.S.C. 3702 of the Act, including the requirement to compute the wages of every mechanic and laborer on the basis of a standard work week of 40 hours. Work in excess of the standard work week is permissible provided that the worker is compensated at a rate of not less than one and a half times the basic rate of pay for all hours worked in excess of 40 hours in the work week. The requirements of 40 U.S.C. 3704 are applicable to construction work and provide that no laborer or mechanic must be required to work in surroundings or under working conditions which are unsanitary, hazardous or dangerous.

g. Rights to Inventions Made Under a Contract or Agreement - If the Federal award meets the definition of "funding agreement" under 37 CFR §401.2 (a) and the Contractor or a subcontractor wishes to enter into a contract with a small business firm or nonprofit organization regarding the substitution of parties, assignment or performance of experimental, developmental, or research work under that "funding agreement," the Contractor or subcontractor must comply with the requirements of 37 CFR Part 401, "Rights to Inventions Made by Nonprofit Organizations and Small

Business Firms Under Government Grants, Contracts and Cooperative Agreements,” and any implementing regulations issued by the awarding agency.

h. Clean Air Act (42 U.S.C. 7401-7671q.) and the Federal Water Pollution Control Act (33 U.S.C. 1251-1387), as amended - For contracts and subcontracts that are in excess of \$150,000, the Contractor and subcontractor must comply with all applicable standards, orders or regulations issued pursuant to the Clean Air Act (42 U.S.C. 7401-7671q) and the Federal Water Pollution Control Act as amended (33 U.S.C. 1251-1387). Violations must be reported to the Federal awarding agency and the Regional Office of the Environmental Protection Agency (EPA).

i. Debarment and Suspension (Executive Orders 12549 and 12689) - A contract award (see 2 CFR 180.220) must not be made to parties listed on the governmentwide exclusions in the System for Award Management (SAM), in accordance with the OMB guidelines at 2 CFR 180 that implement Executive Orders 12549 (3 CFR part 1986 Comp., p. 189) and 12689 (3 CFR part 1989 Comp., p. 235), “Debarment and Suspension.” SAM Exclusions contains the names of parties debarred, suspended, or otherwise excluded by agencies, as well as parties declared ineligible under statutory or regulatory authority other than Executive Order 12549.

j. Byrd Anti-Lobbying Amendment (31 U.S.C. 1352) - The Contractor, and each subcontractor that applies or bids for a subcontract exceeding \$100,000, must file the required Anti-Lobbying certification attached in Exhibit A-6 hereto and incorporated herein. Each tier certifies to the tier above that it will not and has not used Federal appropriated funds to pay any person or organization for influencing or attempting to influence an officer or employee of any agency, a member of Congress, officer or employee of Congress, or an employee of a member of Congress in connection with obtaining any Federal contract, grant or any other award covered by 31 U.S.C. 1352. Each tier must also disclose any lobbying with non-Federal funds that takes place in connection with obtaining any Federal award. Such disclosures are forwarded from tier to tier up to the non-Federal award. The Contractor must obtain and forward the Certification to the Alamo Colleges District.

k. Procurement of Recovered Materials - Contractor must comply with section 6002 of the Solid Waste Disposal Act, as amended by the Resource Conservation and Recovery Act. The requirements of Section 6002 include procuring only items designated in guidelines of the Environmental Protection Agency (EPA) at 40 CFR part 247 that contain the highest percentage of recovered materials practicable, consistent with maintaining a satisfactory level of competition, where the purchase price of the item exceeds \$10,000 or the value of the quantity acquired during the preceding fiscal year exceeded \$10,000; procuring solid waste management services in a manner that maximizes energy and resource recovery; and establishing an affirmative procurement program for procurement of recovered materials identified in the EPA guidelines.

**IN WITNESS WHEREOF**, the parties hereto have caused this Agreement to be duly executed and the Owner's signature, which shall occur last, is made on this \_\_\_ day of \_\_\_\_\_, 201\_\_.

**CONTRACTOR:**

**OWNER:**

  
**District**

**Alamo Community College**

By: \_\_\_\_\_

By: \_\_\_\_\_

Name: \_\_\_\_\_

Name: \_\_\_\_\_

Capacity: \_\_\_\_\_

Capacity: \_\_\_\_\_

[End of Part I]

## PART II

### SCOPE OF SERVICES

Subject to the terms and conditions of this Agreement, the Contractor shall provide services and/or materials for the Project, in accordance with the applicable plans, specifications, drawings, rules and regulations including the following:

1. The Project description, plans and scope of work includes providing service and materials necessary to [REDACTED];
2. The drawings, plans and specifications are described as follows and attached hereto:
  - 2.1. [REDACTED]; and
  - 2.2. [REDACTED].

Contractor shall timely respond to requests for information, clarifications and meetings and achieve Substantial and Final Completion of the Work within the Contract Time.

Owner does not guarantee the accuracy of the drawings, plans, specification, reports, test and other documents provided under this Agreement. Accordingly, Contractor must check and verify all essential field measurements and carefully study the drawings, plans and specifications.

Contractor shall perform all the other separately identifiable parts thereof required to complete the Project and provide all the necessary materials and labor to timely complete the Project and the items above.

Contractor shall comply with Owner's Design and Construction Standards available online at: <https://www.alamo.edu/about-us/offices-departments/departments/facilities-and-construction-management/>

[End of Part II]

**PART III**  
**PAYMENT SCHEDULE**  
[10% retainage]

The Owner shall pay the Contractor for the performance of the Work on one or more of the following basis:

Guaranteed Maximum Cost of \$ \_\_\_\_\_ ;

Lump Sum of \$ \_\_\_\_\_ ;

Unit Price of \_\_\_\_\_ ;

Cost Plus Not to Exceed the sum of \$ \_\_\_\_\_ ; or

As described on the attached document marked as EXHIBIT B.

Subject to compliance by the Contractor with the terms and conditions of this Agreement and the Owner approved Schedule of Values, if any, Contractor may make application for monthly progress payments for 90 percent of the value of labor and materials incorporated in the Work and for materials and equipment delivered and suitably stored at the site of the Work. All applications for payment must be accompanied by invoices, receipts and a properly executed Waiver of Lien from Contractor, each Subcontractor and Material Supplier engaged in the Work, waiving their rights to claim a lien with respect to the amounts for which payment is requested. In addition, all applications for payment must be accompanied by any other document or information requested by the Owner.

Contractor shall submit an initial project schedule for approval by Owner, which shows timely completion of the Work. The project schedule shall be updated monthly and submitted with each application for payment for approval by Owner. If an updated project schedule indicates that previously-approved schedules may not be met, then the Contractor shall make appropriate recommendations to the Owner and, upon written approval of the Owner, shall implement necessary corrective action.

Neither payment nor partial use or occupancy constitutes acceptance of defective or nonconforming work or otherwise relieve Contractor of any obligation under the contract. However, if Contractor defaults or neglects to carry out the Work in accordance with the Contract Documents, Owner may, without prejudice to any other remedy it may have, make good such deficiencies and may deduct the cost thereof from the payment then or thereafter due Contractor or, at Owner's option, may terminate the Contract and finish the Work by whatever method owner deems expedient. Owner may seek to have Contractor pay for the cost of such deficiencies or the cost of finishing the Work.

Final payment of the ten (10) percent retainage will be made within forty five days after completion and final written acceptance of the Work by Owner. Final payment shall not constitute a waiver

of claims by Owner against Contractor. However, Contractor, by accepting Final Payment, releases Owner from all claims and liability arising out of this Agreement or its performance of the Work.

Upon receipt of written notice that the Work is ready for final inspection and acceptance, the Owner or its representative shall promptly make such inspection, and when it finds the work acceptable under the Contract and the Contract fully performed it shall promptly issue a certificate of final payment, stating that the work provided for in the Contract has been completed and is accepted by it under the terms and conditions thereof, and that the entire balance found to be due the Contractor, and noted in said certificate of final payment, is due and payable.

Before issuance of the certificate of final payment, all approvals necessary in connection with the work shall have been secured. The Owner may examine books and records of the Contractor or any subcontractor to corroborate any reasonable independent evidence indicating indebtedness or other liability in connection with the work. Before issuance of the certificate of final payment, the Contractor shall also deliver to the Owner, with respect to the Contractor that such subcontractor agrees to repair, at its own expense and at the convenience of the Owner, any defects in workmanship or materials discovered within two (2) years from the date of issuance of the final payment, and any substantial defects resulting from failure to comply with the Contract Documents whenever discovered. At the same time the Contractor shall also deliver to the Owner a written guarantee in the same terms on behalf of the Contractor.

No overtime work or premium rates will be paid or authorized by Contractor unless Owner has expressly approved such payment in writing.

Contractor shall assume full responsibility for payments of federal, state and local taxes on contributions imposed or required under the social security, worker's compensation and income tax laws.

[End of Part III]

# Exhibit A

<b>EXHIBIT A-1</b>	Texas Government Code Chapter 2258
<b>EXHIBIT A-2</b>	Federal DBRA Regulations
<b>EXHIBIT A-3</b>	DBRA Wage Rate Determination
<b>EXHIBIT A-4</b>	Required DBRA Job Site Notice
<b>EXHIBIT A-5</b>	Criminal Background Check Certification

EXHIBIT A-1  
Texas Government Code Chapter 2258

GOVERNMENT CODE  
TITLE 10. GENERAL GOVERNMENT  
SUBTITLE F. STATE AND LOCAL CONTRACTS AND FUND MANAGEMENT  
CHAPTER 2258. PREVAILING WAGE RATES  
SUBCHAPTER A. GENERAL PROVISIONS

Sec. 2258.001. DEFINITIONS. In this chapter:

(1) "Locality in which the work is performed" means:

(A) for a contract for a public work awarded by the state, the political subdivision of the state in which the public work is located:

(i) which may include a county, municipality, county and municipality, or district, except as provided by Subparagraph (ii); and

(ii) which, in a municipality with a population of 500,000 or more, may only include the geographic limits of the municipality; or

(B) for a contract for a public work awarded by a political subdivision of the state, the geographical limits of the political subdivision.

(2) "Public body" means a public body awarding a contract for a public work on behalf of the state or a political subdivision of the state.

(3) "Worker" includes a laborer or mechanic.

Added by Acts 1995, 74th Leg., ch. 76, Sec. 5.49(a), eff. Sept. 1, 1995. Amended by Acts 2001, 77th Leg., ch. 1422, Sec. 14.04, eff. Sept. 1, 2001.

Sec. 2258.002. APPLICABILITY OF CHAPTER TO PUBLIC WORKS.

(a) This chapter applies only to the construction of a public work, including a building, highway, road, excavation, and repair work or other project development or improvement, paid for in whole or in part from public funds, without regard to whether the work is done under public supervision or direction.

(b) This chapter does not apply to work done directly by a public utility company under an order of a public authority.

Added by Acts 1995, 74th Leg., ch. 76, Sec. 5.49(a), eff. Sept. 1, 1995.

Sec. 2258.003. LIABILITY. An officer, agent, or employee of a public body is not liable in a civil action for any act or omission implementing or enforcing this chapter unless the action was made in bad faith.

Added by Acts 1995, 74th Leg., ch. 76, Sec. 5.49(a), eff. Sept. 1, 1995.

SUBCHAPTER B. PAYMENT OF PREVAILING WAGE RATES

Sec. 2258.021. RIGHT TO BE PAID PREVAILING WAGE RATES.



(a) A worker employed on a public work by or on behalf of the state or a political subdivision of the state shall be paid:

(1) not less than the general prevailing rate of per diem wages for work of a similar character in the locality in which the work is performed; and

(2) not less than the general prevailing rate of per diem wages for legal holiday and overtime work.

(b) Subsection (a) does not apply to maintenance work.

(c) A worker is employed on a public work for the purposes of this section if the worker is employed by a contractor or subcontractor in the execution of a contract for the public work with the state, a political subdivision of the state, or any officer or public body of the state or a political subdivision of the state.

Added by Acts 1995, 74th Leg., ch. 76, Sec. 5.49(a), eff. Sept. 1, 1995. Amended by Acts 1997, 75th Leg., ch. 165, Sec. 18.01, eff. Sept. 1, 1997.

#### Sec. 2258.022. DETERMINATION OF PREVAILING WAGE RATES.

(a) For a contract for a public work awarded by a political subdivision of the state, the public body shall determine the general prevailing rate of per diem wages in the locality in which the public work is to be performed for each craft or type of worker needed to execute the contract and the prevailing rate for legal holiday and overtime work by:

(1) conducting a survey of the wages received by classes of workers employed on projects of a character similar to the contract work in the political subdivision of the state in which the public work is to be performed; or

(2) using the prevailing wage rate as determined by the United States Department of Labor in accordance with the Davis-Bacon Act (40 U.S.C. Section 276a et seq.), and its subsequent amendments.

(b) This subsection applies only to a public work located in a county bordering the United Mexican States or in a county adjacent to a county bordering the United Mexican States. For a contract for a public work awarded by the state, the public body shall determine the general prevailing rate of per diem wages in the locality in which the public work is to be performed for each craft or type of worker needed to execute the contract and the prevailing rate for legal holiday and overtime work as follows. The public body shall conduct a survey of the wages received by classes of workers employed on projects of a character similar to the contract work both statewide and in the political subdivision of the state in which the public work is to be performed. The public body shall also consider the prevailing wage rate as determined by the United States Department of Labor in accordance with the Davis-Bacon Act (40 U.S.C. Section 276a et seq.), and its subsequent amendments, but only if the survey used to determine that rate was conducted within a three-year period preceding the date the public body calls for bids for the public work. The public body shall determine the general prevailing rate of per diem wages in the locality based on the higher of:

(1) the rate determined from the survey conducted in the political subdivision;

(2) the arithmetic mean between the rate determined from the survey conducted in the political subdivision and the rate determined from the statewide survey; and

(3) if applicable, the arithmetic mean between the rate determined from the survey conducted in the political subdivision and the rate determined by the United States Department of Labor.

(c) The public body shall determine the general prevailing rate of per diem wages as a sum certain, expressed in dollars and cents.

(d) A public body shall specify in the call for bids for the contract and in the contract itself the wage rates determined under this section.

(e) The public body's determination of the general prevailing rate of per diem wages is final.

Added by Acts 1995, 74th Leg., ch. 76, Sec. 5.49(a), eff. Sept. 1, 1995. Amended by Acts 1997, 75th Leg., ch. 165, Sec. 18.02, eff. Sept. 1, 1997; Acts 2001, 77th Leg., ch. 1422, Sec. 14.05, eff. Sept. 1, 2001.

Amended by:

Acts 2007, 80th Leg., R.S., Ch. 728 (H.B. [2625](#)), Sec. 1, eff. September 1, 2007.

**Sec. 2258.023. PREVAILING WAGE RATES TO BE PAID BY CONTRACTOR AND SUBCONTRACTOR; PENALTY.**

(a) The contractor who is awarded a contract by a public body or a subcontractor of the contractor shall pay not less than the rates determined under Section [2258.022](#) to a worker employed by it in the execution of the contract.

(b) A contractor or subcontractor who violates this section shall pay to the state or a political subdivision of the state on whose behalf the contract is made, \$60 for each worker employed for each calendar day or part of the day that the worker is paid less than the wage rates stipulated in the contract. A public body awarding a contract shall specify this penalty in the contract.

(c) A contractor or subcontractor does not violate this section if a public body awarding a contract does not determine the prevailing wage rates and specify the rates in the contract as provided by Section [2258.022](#).

(d) The public body shall use any money collected under this section to offset the costs incurred in the administration of this chapter.

(e) A municipality is entitled to collect a penalty under this section only if the municipality has a population of more than 10,000.

Added by Acts 1995, 74th Leg., ch. 76, Sec. 5.49(a), eff. Sept. 1, 1995.

**Sec. 2258.024. RECORDS.**

(a) A contractor and subcontractor shall keep a record showing:

(1) the name and occupation of each worker employed by the contractor or subcontractor in the construction of the public work; and

(2) the actual per diem wages paid to each worker.

(b) The record shall be open at all reasonable hours to inspection by the officers and agents of the public body.

Added by Acts 1995, 74th Leg., ch. 76, Sec. 5.49(a), eff. Sept. 1, 1995.

Sec. 2258.025. PAYMENT GREATER THAN PREVAILING RATE NOT PROHIBITED. This chapter does not prohibit the payment to a worker employed on a public work an amount greater than the general prevailing rate of per diem wages.

Added by Acts 1995, 74th Leg., ch. 76, Sec. 5.49(a), eff. Sept. 1, 1995.

Sec. 2258.026. RELIANCE ON CERTIFICATE OF SUBCONTRACTOR. A contractor is entitled to rely on a certificate by a subcontractor regarding the payment of all sums due those working for the subcontractor until the contrary has been determined.

Added by Acts 1995, 74th Leg., ch. 76, Sec. 5.49(a), eff. Sept. 1, 1995.

### SUBCHAPTER C. ENFORCEMENT; CIVIL AND CRIMINAL PENALTIES

Sec. 2258.051. DUTY OF PUBLIC BODY TO HEAR COMPLAINTS AND WITHHOLD PAYMENT. A public body awarding a contract, and an agent or officer of the public body, shall:

- (1) take cognizance of complaints of all violations of this chapter committed in the execution of the contract; and
- (2) withhold money forfeited or required to be withheld under this chapter from the payments to the contractor under the contract, except that the public body may not withhold money from other than the final payment without a determination by the public body that there is good cause to believe that the contractor has violated this chapter.

Added by Acts 1995, 74th Leg., ch. 76, Sec. 5.49(a), eff. Sept. 1, 1995.

Sec. 2258.052. COMPLAINT; INITIAL DETERMINATION.

(a) On receipt of information, including a complaint by a worker, concerning an alleged violation of Section [2258.023](#) by a contractor or subcontractor, a public body shall make an initial determination as to whether good cause exists to believe that the violation occurred.

(b) A public body must make its determination under Subsection (a) before the 31st day after the date the public body receives the information.

(c) A public body shall notify in writing the contractor or subcontractor and any affected worker of its initial determination.

(d) A public body shall retain any amount due under the contract pending a final determination of the violation.

Added by Acts 1995, 74th Leg., ch. 76, Sec. 5.49(a), eff. Sept. 1, 1995.

Sec. 2258.053. ARBITRATION REQUIRED FOR UNRESOLVED ISSUE.

(a) An issue relating to an alleged violation of Section [2258.023](#), including a penalty owed to a public body or an affected worker, shall be submitted to binding arbitration in accordance with the Texas General Arbitration Act (Article 224 et seq., Revised Statutes) if the contractor or subcontractor and any affected worker do not resolve the issue by agreement before

the 15th day after the date the public body makes its initial determination under Section [2258.052](#).

(b) If the persons required to arbitrate under this section do not agree on an arbitrator before the 11th day after the date that arbitration is required under Subsection (a), a district court shall appoint an arbitrator on the petition of any of the persons.

(c) A public body is not a party in the arbitration.

Added by Acts 1995, 74th Leg., ch. 76, Sec. 5.49(a), eff. Sept. 1, 1995.

Sec. 2258.054. ARBITRATION AWARD; COSTS.

(a) If an arbitrator determines that Section [2258.023](#) has been violated, the arbitrator shall assess and award against the contractor or subcontractor:

- (1) penalties as provided by Section [2258.023](#) and this section; and
- (2) all amounts owed to the affected worker.

(b) An arbitrator shall assess and award all reasonable costs, including the arbitrator's fee, against the party who does not prevail. Costs may be assessed against the worker only if the arbitrator finds that the claim is frivolous. If the arbitrator does not find that the claim is frivolous and does not make an award to the worker, costs are shared equally by the parties.

Added by Acts 1995, 74th Leg., ch. 76, Sec. 5.49(a), eff. Sept. 1, 1995.

Sec. 2258.055. ARBITRATION DECISION AND AWARD FINAL. The decision and award of the arbitrator is final and binding on all parties and may be enforced in any court of competent jurisdiction.

Added by Acts 1995, 74th Leg., ch. 76, Sec. 5.49(a), eff. Sept. 1, 1995.

Sec. 2258.056. PAYMENT BY PUBLIC BODY TO WORKER; ACTION TO RECOVER PAYMENT.

(a) A public body shall use any amounts retained under this chapter to pay the worker the difference between the amount the worker received in wages for labor on the public work at the rate paid by the contractor or subcontractor and the amount the worker would have received at the general prevailing wage rate as provided in the arbitrator's award.

(b) The public body may adopt rules, orders, or ordinances relating to the manner in which a reimbursement is made.

(c) If the amounts retained by a public body under this chapter are not sufficient for the public body to pay the worker the full amount owed, the worker has a right of action against the contractor or subcontractor and the surety of the contractor or subcontractor to recover the amount owed, reasonable attorney's fees, and court costs.

Added by Acts 1995, 74th Leg., ch. 76, Sec. 5.49(a), eff. Sept. 1, 1995.

Sec. 2258.057. WITHHOLDING BY CONTRACTOR.

(a) A contractor may withhold from a subcontractor sufficient money to cover an amount withheld from the contractor by a public body because the subcontractor violated this chapter.

(b) If the contractor has made a payment to the subcontractor, the contractor may withhold money from any future payments owed to the subcontractor or sue the subcontractor or the subcontractor's surety for the amount withheld from the contractor by a public body because of the subcontractor's violation.

Added by Acts 1995, 74th Leg., ch. 76, Sec. 5.49(a), eff. Sept. 1, 1995.

Sec. 2258.058. CRIMINAL OFFENSE.

(a) An officer, agent, or representative of the state or of a political subdivision of the state commits an offense if the person wilfully violates or does not comply with a provision of this chapter.

(b) A contractor or subcontractor of a public work under this chapter, or an agent or representative of the contractor or subcontractor, commits an offense if the person violates Section [2258.024](#).

(c) An offense under this section is punishable by:

- (1) a fine not to exceed \$500;
- (2) confinement in jail for a term not to exceed six months; or
- (3) both a fine and confinement.

Added by Acts 1995, 74th Leg., ch. 76, Sec. 5.49(a), eff. Sept. 1, 1995.

**EXHIBIT A-2**  
**DBRA AUTHORITIES**

(1) *Minimum wages.* (i) All laborers and mechanics employed or working upon the site of the work (or under the United States Housing Act of 1937 or under the Housing Act of 1949 in the construction or development of the project), will be paid unconditionally and not less often than once a week, and without subsequent deduction or rebate on any account (except such payroll deductions as are permitted by regulations issued by the Secretary of Labor under the Copeland Act (29 CFR part 3)), the full amount of wages and bona fide fringe benefits (or cash equivalents thereof) due at time of payment computed at rates not less than those contained in the wage determination of the Secretary of Labor which is attached hereto and made a part hereof, regardless of any contractual relationship which may be alleged to exist between the contractor and such laborers and mechanics.

Contributions made or costs reasonably anticipated for bona fide fringe benefits under section 1(b)(2) of the Davis-Bacon Act on behalf of laborers or mechanics are considered wages paid to such laborers or mechanics, subject to the provisions of paragraph (a)(1)(iv) of this section; also, regular contributions made or costs incurred for more than a weekly period (but not less often than quarterly) under plans, funds, or programs which cover the particular weekly period, are deemed to be constructively made or incurred during such weekly period. Such laborers and mechanics shall be paid the appropriate wage rate and fringe benefits on the wage determination for the classification of work actually performed, without regard to skill, except as provided in §5.5(a)(4). Laborers or mechanics performing work in more than one classification may be compensated at the rate specified for each classification for the time actually worked therein: *Provided*, That the employer's payroll records accurately set forth the time spent in each classification in which work is performed. The wage determination (including any additional classification and wage rates conformed under paragraph (a)(1)(ii) of this section) and the Davis-Bacon poster (WH-1321) shall be posted at all times by the contractor and its subcontractors at the site of the work in a prominent and accessible place where it can be easily seen by the workers.

(ii) (A) The contracting officer shall require that any class of laborers or mechanics, including helpers, which is not listed in the wage determination and which is to be employed under the contract shall be classified in conformance with the wage determination. The contracting officer shall approve an additional classification and wage rate and fringe benefits therefore only when the following criteria have been met:

(1) The work to be performed by the classification requested is not performed by a classification in the wage determination; and

(2) The classification is utilized in the area by the construction industry;  
and

(3) The proposed wage rate, including any bona fide fringe benefits, bears a reasonable relationship to the wage rates contained in the wage determination.

(B) If the contractor and the laborers and mechanics to be employed in the classification (if known), or their representatives, and the contracting officer agree on the

classification and wage rate (including the amount designated for fringe benefits where appropriate), a report of the action taken shall be sent by the contracting officer to the Administrator of the Wage and Hour Division, Employment Standards Administration, U.S. Department of Labor, Washington, DC 20210. The Administrator, or an authorized representative, will approve, modify, or disapprove every additional classification action within 30 days of receipt and so advise the contracting officer or will notify the contracting officer within the 30-day period that additional time is necessary.

(C) In the event the contractor, the laborers or mechanics to be employed in the classification or their representatives, and the contracting officer do not agree on the proposed classification and wage rate (including the amount designated for fringe benefits, where appropriate), the contracting officer shall refer the questions, including the views of all interested parties and the recommendation of the contracting officer, to the Administrator for determination. The Administrator, or an authorized representative, will issue a determination within 30 days of receipt and so advise the contracting officer or will notify the contracting officer within the 30-day period that additional time is necessary.

(D) The wage rate (including fringe benefits where appropriate) determined pursuant to paragraphs (a)(1)(ii) (B) or (C) of this section, shall be paid to all workers performing work in the classification under this contract from the first day on which work is performed in the classification.

(iii) Whenever the minimum wage rate prescribed in the contract for a class of laborers or mechanics includes a fringe benefit which is not expressed as an hourly rate, the contractor shall either pay the benefit as stated in the wage determination or shall pay another bona fide fringe benefit or an hourly cash equivalent thereof.

(iv) If the contractor does not make payments to a trustee or other third person, the contractor may consider as part of the wages of any laborer or mechanic the amount of any costs reasonably anticipated in providing bona fide fringe benefits under a plan or program, *Provided*, That the Secretary of Labor has found, upon the written request of the contractor, that the applicable standards of the Davis-Bacon Act have been met. The Secretary of Labor may require the contractor to set aside in a separate account assets for the meeting of obligations under the plan or program.

(2) *Withholding*. The (write in name of Federal Agency or the loan or grant recipient) shall upon its own action or upon written request of an authorized representative of the Department of Labor withhold or cause to be withheld from the contractor under this contract or any other Federal contract with the same prime contractor, or any other federally-assisted contract subject to Davis-Bacon prevailing wage requirements, which is held by the same prime contractor, so much of the accrued payments or advances as may be considered necessary to pay laborers and mechanics, including apprentices, trainees, and helpers, employed by the contractor or any subcontractor the full amount of wages required by the contract. In the event of failure to pay any laborer or mechanic, including any apprentice, trainee, or helper, employed or working on the site of the work (or under the United States Housing Act of 1937 or under the Housing Act of 1949 in the construction or development of the project), all or part of the wages required by the contract, the (Agency) may, after written notice to the contractor, sponsor, applicant, or owner,

take such action as may be necessary to cause the suspension of any further payment, advance, or guarantee of funds until such violations have ceased.

(3) *Payrolls and basic records.*

(i) Payrolls and basic records relating thereto shall be maintained by the contractor during the course of the work and preserved for a period of three years thereafter for all laborers and mechanics working at the site of the work (or under the United States Housing Act of 1937, or under the Housing Act of 1949, in the construction or development of the project). Such records shall contain the name, address, and social security number of each such worker, his or her correct classification, hourly rates of wages paid (including rates of contributions or costs anticipated for bona fide fringe benefits or cash equivalents thereof of the types described in section 1(b)(2)(B) of the Davis-Bacon Act), daily and weekly number of hours worked, deductions made and actual wages paid. Whenever the Secretary of Labor has found under 29 CFR 5.5(a)(1)(iv) that the wages of any laborer or mechanic include the amount of any costs reasonably anticipated in providing benefits under a plan or program described in section 1(b)(2)(B) of the Davis-Bacon Act, the contractor shall maintain records which show that the commitment to provide such benefits is enforceable, that the plan or program is financially responsible, and that the plan or program has been communicated in writing to the laborers or mechanics affected, and records which show the costs anticipated or the actual cost incurred in providing such benefits. Contractors employing apprentices or trainees under approved programs shall maintain written evidence of the registration of apprenticeship programs and certification of trainee programs, the registration of the apprentices and trainees, and the ratios and wage rates prescribed in the applicable programs.

(ii) (A) The contractor shall submit weekly for each week in which any contract work is performed a copy of all payrolls to the (write in name of appropriate federal agency) if the agency is a party to the contract, but if the agency is not such a party, the contractor will submit the payrolls to the applicant, sponsor, or owner, as the case may be, for transmission to the (write in name of agency). The payrolls submitted shall set out accurately and completely all of the information required to be maintained under 29 CFR 5.5(a)(3)(i), except that full social security numbers and home addresses shall not be included on weekly transmittals. Instead the payrolls shall only need to include an individually identifying number for each employee (*e.g.*, the last four digits of the employee's social security number). The required weekly payroll information may be submitted in any form desired. Optional Form WH-347 is available for this purpose from the Wage and Hour Division Web site at <http://www.dol.gov/esa/whd/forms/wh347instr.htm> or its successor site. The prime contractor is responsible for the submission of copies of payrolls by all subcontractors. Contractors and subcontractors shall maintain the full social security number and current address of each covered worker, and shall provide them upon request to the (write in name of appropriate federal agency) if the agency is a party to the contract, but if the agency is not such a party, the contractor will submit them to the applicant, sponsor, or owner, as the case may be, for transmission to the (write in name of agency), the contractor, or the Wage and Hour Division of the Department of Labor for purposes of an investigation or audit of compliance with prevailing wage requirements. It is not a violation of this section for a prime contractor to require a subcontractor to provide addresses and social security numbers to the prime contractor for its own records, without weekly submission to the sponsoring government agency (or the applicant, sponsor, or owner).



(B) Each payroll submitted shall be accompanied by a “Statement of Compliance,” signed by the contractor or subcontractor or his or her agent who pays or supervises the payment of the persons employed under the contract and shall certify the following:

(1) That the payroll for the payroll period contains the information required to be provided under §5.5 (a)(3)(ii) of Regulations, 29 CFR part 5, the appropriate information is being maintained under §5.5 (a)(3)(i) of Regulations, 29 CFR part 5, and that such information is correct and complete;

(2) That each laborer or mechanic (including each helper, apprentice, and trainee) employed on the contract during the payroll period has been paid the full weekly wages earned, without rebate, either directly or indirectly, and that no deductions have been made either directly or indirectly from the full wages earned, other than permissible deductions as set forth in Regulations, 29 CFR part 3;

(3) That each laborer or mechanic has been paid not less than the applicable wage rates and fringe benefits or cash equivalents for the classification of work performed, as specified in the applicable wage determination incorporated into the contract.

(C) The weekly submission of a properly executed certification set forth on the reverse side of Optional Form WH-347 shall satisfy the requirement for submission of the “Statement of Compliance” required by paragraph (a)(3)(ii)(B) of this section.

(D) The falsification of any of the above certifications may subject the contractor or subcontractor to civil or criminal prosecution under section 1001 of title 18 and section 231 of title 31 of the United States Code.

(iii) The contractor or subcontractor shall make the records required under paragraph (a)(3)(i) of this section available for inspection, copying, or transcription by authorized representatives of the (write the name of the agency) or the Department of Labor, and shall permit such representatives to interview employees during working hours on the job. If the contractor or subcontractor fails to submit the required records or to make them available, the Federal agency may, after written notice to the contractor, sponsor, applicant, or owner, take such action as may be necessary to cause the suspension of any further payment, advance, or guarantee of funds. Furthermore, failure to submit the required records upon request or to make such records available may be grounds for debarment action pursuant to 29 CFR 5.12.

(4) *Apprentices and trainees.*

(i) *Apprentices.* Apprentices will be permitted to work at less than the predetermined rate for the work they performed when they are employed pursuant to and individually registered in a bona fide apprenticeship program registered with the U.S. Department of Labor, Employment and Training Administration, Office of Apprenticeship Training, Employer and Labor Services, or with a State Apprenticeship Agency recognized by the Office, or if a person is employed in his or her first 90 days of probationary employment as an apprentice in such an apprenticeship program, who is not individually registered in the program, but who has been certified by the Office of Apprenticeship Training, Employer and Labor Services or a State Apprenticeship Agency (where appropriate) to be eligible for probationary employment as an apprentice. The

allowable ratio of apprentices to journeymen on the job site in any craft classification shall not be greater than the ratio permitted to the contractor as to the entire work force under the registered program. Any worker listed on a payroll at an apprentice wage rate, who is not registered or otherwise employed as stated above, shall be paid not less than the applicable wage rate on the wage determination for the classification of work actually performed. In addition, any apprentice performing work on the job site in excess of the ratio permitted under the registered program shall be paid not less than the applicable wage rate on the wage determination for the work actually performed. Where a contractor is performing construction on a project in a locality other than that in which its program is registered, the ratios and wage rates (expressed in percentages of the journeyman's hourly rate) specified in the contractor's or subcontractor's registered program shall be observed. Every apprentice must be paid at not less than the rate specified in the registered program for the apprentice's level of progress, expressed as a percentage of the journeymen hourly rate specified in the applicable wage determination. Apprentices shall be paid fringe benefits in accordance with the provisions of the apprenticeship program. If the apprenticeship program does not specify fringe benefits, apprentices must be paid the full amount of fringe benefits listed on the wage determination for the applicable classification. If the Administrator determines that a different practice prevails for the applicable apprentice classification, fringes shall be paid in accordance with that determination. In the event the Office of Apprenticeship Training, Employer and Labor Services, or a State Apprenticeship Agency recognized by the Office, withdraws approval of an apprenticeship program, the contractor will no longer be permitted to utilize apprentices at less than the applicable predetermined rate for the work performed until an acceptable program is approved.

(ii) *Trainees*. Except as provided in 29 CFR 5.16, trainees will not be permitted to work at less than the predetermined rate for the work performed unless they are employed pursuant to and individually registered in a program which has received prior approval, evidenced by formal certification by the U.S. Department of Labor, Employment and Training Administration. The ratio of trainees to journeymen on the job site shall not be greater than permitted under the plan approved by the Employment and Training Administration. Every trainee must be paid at not less than the rate specified in the approved program for the trainee's level of progress, expressed as a percentage of the journeyman hourly rate specified in the applicable wage determination. Trainees shall be paid fringe benefits in accordance with the provisions of the trainee program. If the trainee program does not mention fringe benefits, trainees shall be paid the full amount of fringe benefits listed on the wage determination unless the Administrator of the Wage and Hour Division determines that there is an apprenticeship program associated with the corresponding journeyman wage rate on the wage determination which provides for less than full fringe benefits for apprentices. Any employee listed on the payroll at a trainee rate who is not registered and participating in a training plan approved by the Employment and Training Administration shall be paid not less than the applicable wage rate on the wage determination for the classification of work actually performed. In addition, any trainee performing work on the job site in excess of the ratio permitted under the registered program shall be paid not less than the applicable wage rate on the wage determination for the work actually performed. In the event the Employment and Training Administration withdraws approval of a training program, the contractor will no longer be permitted to utilize trainees at less than the applicable predetermined rate for the work performed until an acceptable program is approved.

(iii) *Equal employment opportunity.* The utilization of apprentices, trainees and journeymen under this part shall be in conformity with the equal employment opportunity requirements of Executive Order 11246, as amended, and 29 CFR part 30.

(5) *Compliance with Copeland Act requirements.* The contractor shall comply with the requirements of 29 CFR part 3, which are incorporated by reference in this contract.

(6) *Subcontracts.* The contractor or subcontractor shall insert in any subcontracts the clauses contained in 29 CFR 5.5(a)(1) through (10) and such other clauses as the (write in the name of the Federal agency) may by appropriate instructions require, and also a clause requiring the subcontractors to include these clauses in any lower tier subcontracts. The prime contractor shall be responsible for the compliance by any subcontractor or lower tier subcontractor with all the contract clauses in 29 CFR 5.5.

(7) *Contract termination: debarment.* A breach of the contract clauses in 29 CFR 5.5 may be grounds for termination of the contract, and for debarment as a contractor and a subcontractor as provided in 29 CFR 5.12.

(8) *Compliance with Davis-Bacon and Related Act requirements.* All rulings and interpretations of the Davis-Bacon and Related Acts contained in 29 CFR parts 1, 3, and 5 are herein incorporated by reference in this contract.

(9) *Disputes concerning labor standards.* Disputes arising out of the labor standards provisions of this contract shall not be subject to the general disputes clause of this contract. Such disputes shall be resolved in accordance with the procedures of the Department of Labor set forth in 29 CFR parts 5, 6, and 7. Disputes within the meaning of this clause include disputes between the contractor (or any of its subcontractors) and the contracting agency, the U.S. Department of Labor, or the employees or their representatives.

(10) *Certification of eligibility.*

(i) By entering into this contract, the contractor certifies that neither it (nor he or she) nor any person or firm who has an interest in the contractor's firm is a person or firm ineligible to be awarded Government contracts by virtue of section 3(a) of the Davis-Bacon Act or 29 CFR 5.12(a)(1).

(ii) No part of this contract shall be subcontracted to any person or firm ineligible for award of a Government contract by virtue of section 3(a) of the Davis-Bacon Act or 29 CFR 5.12(a)(1).

(iii) (a) The penalty for making false statements is prescribed in the U.S. Criminal Code, 18 U.S.C. 1001.

(b) *Contract Work Hours and Safety Standards Act.* The Agency Head shall cause or require the contracting officer to insert the following clauses set forth in paragraphs (b)(1), (2), (3), and (4) of this section in full in any contract in an amount in excess of \$100,000 and subject to the overtime provisions of the Contract Work Hours and Safety Standards Act. These clauses shall be inserted in addition to the clauses required by §5.5(a) or §4.6 of part 4 of this title. As used in this paragraph, the terms *laborers* and *mechanics* include watchmen and guards.

(1) *Overtime requirements.* No contractor or subcontractor contracting for any part of the contract work which may require or involve the employment of laborers or mechanics shall require or permit any such laborer or mechanic in any workweek in which he or she is employed on such work to work in excess of forty hours in such workweek unless such laborer or mechanic receives compensation at a rate not less than one and one-half times the basic rate of pay for all hours worked in excess of forty hours in such workweek.

(2) *Violation; liability for unpaid wages; liquidated damages.* In the event of any violation of the clause set forth in paragraph (b)(1) of this section the contractor and any subcontractor responsible therefor shall be liable for the unpaid wages. In addition, such contractor and subcontractor shall be liable to the United States (in the case of work done under contract for the District of Columbia or a territory, to such District or to such territory), for liquidated damages. Such liquidated damages shall be computed with respect to each individual laborer or mechanic, including watchmen and guards, employed in violation of the clause set forth in paragraph (b)(1) of this section, in the sum of \$10 for each calendar day on which such individual was required or permitted to work in excess of the standard workweek of forty hours without payment of the overtime wages required by the clause set forth in paragraph (b)(1) of this section.

(3) *Withholding for unpaid wages and liquidated damages.* The (write in the name of the Federal agency or the loan or grant recipient) shall upon its own action or upon written request of an authorized representative of the Department of Labor withhold or cause to be withheld, from any moneys payable on account of work performed by the contractor or subcontractor under any such contract or any other Federal contract with the same prime contractor, or any other federally-assisted contract subject to the Contract Work Hours and Safety Standards Act, which is held by the same prime contractor, such sums as may be determined to be necessary to satisfy any liabilities of such contractor or subcontractor for unpaid wages and liquidated damages as provided in the clause set forth in paragraph (b)(2) of this section.

(4) *Subcontracts.* The contractor or subcontractor shall insert in any subcontracts the clauses set forth in paragraph (b)(1) through (4) of this section and also a clause requiring the subcontractors to include these clauses in any lower tier subcontracts. The prime contractor shall be responsible for compliance by any subcontractor or lower tier subcontractor with the clauses set forth in paragraphs (b)(1) through (4) of this section.

(c) In addition to the clauses contained in paragraph (b), in any contract subject only to the Contract Work Hours and Safety Standards Act and not to any of the other statutes cited in §5.1, the Agency Head shall cause or require the contracting officer to insert a clause requiring that the contractor or subcontractor shall maintain payrolls and basic payroll records during the course of the work and shall preserve them for a period of three years from the completion of the contract for all laborers and mechanics, including guards and watchmen, working on the contract. Such records shall contain the name and address of each such employee, social security number, correct classifications, hourly rates of wages paid, daily and weekly number of hours worked, deductions made, and actual wages paid. Further, the Agency Head shall cause or require the contracting officer to insert in any such contract a clause providing that the records to be maintained under this paragraph shall be made available by the

contractor or subcontractor for inspection, copying, or transcription by authorized representatives of the (write the name of agency) and the Department of Labor, and the contractor or subcontractor will permit such representatives to interview employees during working hours on the job.

EXHIBIT A-3  
DBRA WAGE RATE DETERMINATION

In its resolution of December 17, 2013, the Board of Trustees of the Alamo Community College District (ACCD) adopted the following prevailing Davis Bacon Wage Rates which shall become part of this contract and full compliance with such shall be required.

The Alamo Community College District (or "Owner") is the contracting agency for this construction project. The following statute requires the contracting agency to specify the generally prevailing rates of wages in contracts that are proposal:

Texas Government Code 2258.021 et seq. "Duty of Governmental Entity to Pay Prevailing Wage Rates"

Pursuant to the requirements of this statute, it has been determined that the following rates of wages are paid to various classifications of workers in the locality of this project.

Accordingly, the prevailing wage determination for Building Construction Trades shall be paid to all workers for work located INSIDE a boundary line placed five feet beyond the drip line of building structures, and the prevailing wage determination for Heavy Highway Trades shall be paid to all workers for work located OUTSIDE a boundary line placed five feet beyond the drip line of building structures. In the event a conflict exists for the same classification between two different wage determinations, the Contractor and each subcontractor must pay compensation at the higher rate. A copy of the applicable wage rate schedule for this project (one or both) is attached to this Exhibit.

Wage rates are the minimum total hourly compensation that must be paid by the Contractor and Subcontractor(s). The value of prevailing fringe benefits must be included in the total compensation wage rate. Workers in classifications where rates are not identified shall be paid not less than the general prevailing rate of "Laborer". All hours of work over 40 hours per week are overtime and will be compensated at the rate of 1 and 1/2 times the regular wage.

Apprentices/trainees/helpers, where not otherwise specified, may be compensated at a rate determined mutually by the worker and employer, commensurate with the experience and skill of the worker but a rate neither less than 60% of the journeyman's wage nor less than the "Laborer" rate. At no time shall a journeyman supervise more than two of apprentices, trainees or helpers. All apprentices/trainees/helpers shall be under the direct supervision of a journeyman. The terms journeyman and apprentice apply to both union and independent workers, and are not intended to imply that these positions are union workers only.

"General Decision Number: TX20200231 02/14/2020

Superseded General Decision Number: TX20190231

State: Texas

Construction Type: Building

County: Bexar County in Texas.

BUILDING CONSTRUCTION PROJECTS (does not include single family homes or apartments up to and including 4 stories).

Note: Under Executive Order (EO) 13658, an hourly minimum wage of \$10.80 for calendar year 2020 applies to all contracts subject to the Davis-Bacon Act for which the contract is awarded (and any solicitation was issued) on or after January 1, 2015. If this contract is covered by the EO, the contractor must pay all workers in any classification listed on this wage determination at least \$10.80 per hour (or the applicable wage rate listed on this wage determination, if it is higher) for all hours spent performing on the contract in calendar year 2020. If this contract is covered by the EO and a classification considered necessary for performance of work on the contract does not appear on this wage determination, the contractor must pay workers in that classification at least the wage rate determined through the conformance process set forth in 29 CFR 5.5(a)(1)(ii) (or the EO minimum wage rate, if it is higher than the conformed wage rate). The EO minimum wage rate will be adjusted annually. Please note that this EO applies to the above-mentioned types of contracts entered into by the federal government that are subject to the Davis-Bacon Act itself, but it does not apply to contracts subject only to the Davis-Bacon Related Acts, including those set forth at 29 CFR 5.1(a)(2)-(60). Additional information on contractor requirements and worker protections under the EO is available at www.dol.gov/whd/govcontracts.

Modification Number	Publication Date
0	01/03/2020
1	02/14/2020

ASBE0087-014 01/01/2018

Rates	Fringes
-------	---------

ASBESTOS WORKER/HEAT & FROST INSULATOR (Duct, Pipe and Mechanical System Insulation)....	\$ 22.72	10.02
--	----------	-------

BOIL0074-003 01/01/2017

Rates	Fringes
-------	---------

BOILERMAKER.....	\$ 28.00	22.35
------------------	----------	-------

ELEC0060-003 06/01/2019

Rates	Fringes
-------	---------

ELECTRICIAN (Communication

Technician Only).....\$ 22.55      9%+5.45

-----  
\* ELEC0060-004 06/01/2019

Rates      Fringes

ELECTRICIAN (Excludes Low  
Voltage Wiring).....\$ 28.60      18%+5.45

-----  
\* ELEV0081-001 01/01/2020

Rates      Fringes

ELEVATOR MECHANIC.....\$ 41.90      34.765

FOOTNOTES:

A. 6% under 5 years based on regular hourly rate for all hours worked. 8% over 5 years based on regular hourly rate for all hours worked.

B. Holidays: New Year's Day; Memorial Day; Independence Day; Labor Day; Thanksgiving Day; Friday after Thanksgiving Day; Christmas Day; and Veterans Day.

-----  
ENGI0450-002 04/01/2014

Rates      Fringes

POWER EQUIPMENT OPERATOR  
Cranes.....\$ 34.85      9.85

-----  
IRON0066-013 06/01/2019

Rates      Fringes

IRONWORKER, STRUCTURAL.....\$ 22.70      6.73

-----  
IRON0084-011 06/01/2019

Rates      Fringes

IRONWORKER, ORNAMENTAL.....\$ 24.42      7.12

-----  
PLUM0142-009 08/07/2019

Rates      Fringes

HVAC MECHANIC (HVAC  
Electrical Temperature Control Installation Only).....\$ 30.25      13.36  
HVAC MECHANIC (HVAC Unit Installation Only).....\$ 30.25      13.36  
PIPEFITTER (Including HVAC  
Pipe Installation).....\$ 31.05      13.76  
Including HVAC Pipe Installation



PLUMBER (Excludes HVAC Pipe Installation).....	\$ 31.05	13.76
Excludes HVAC Pipe Installation		

-----  
SFTX0669-002 04/01/2019

Rates	Fringes
-------	---------

SPRINKLER FITTER (Fire Sprinklers).....	\$ 29.53	21.27
---	----------	-------

-----  
SHEE0067-004 06/01/2019

Rates	Fringes
-------	---------

Sheet metal worker		
Excludes HVAC Duct Installation.....	\$ 26.81	16.80
HVAC Duct Installation Only.	\$ 26.81	16.80

-----  
SUTX2014-006 07/21/2014

Rates	Fringes
-------	---------

BRICKLAYER.....	\$ 22.15	0.00
CARPENTER (Acoustical Ceiling Installation Only).....	\$ 17.83	0.00
CARPENTER (Form Work Only).....	\$ 13.63	0.00
CARPENTER, Excludes Acoustical Ceiling Installation, Drywall Hanging, Form Work, and Metal Stud Installation.....	\$ 16.86	4.17
CAULKER.....	\$ 15.00	0.00
CEMENT MASON/CONCRETE FINISHER...	\$ 22.27	5.30
DRYWALL FINISHER/TAPER.....	\$ 13.81	0.00
DRYWALL HANGER AND METAL STUD INSTALLER.....	\$ 15.18	0.00
ELECTRICIAN (Low Voltage Wiring Only).....	\$ 20.39	3.04
IRONWORKER, REINFORCING.....	\$ 12.27	0.00
LABORER: Common or General.....	\$ 10.75	0.00
LABORER: Mason Tender - Brick...	\$ 11.88	0.00
LABORER: Mason Tender - Cement/Concrete.....	\$ 12.00	0.00
LABORER: Pipelayer.....	\$ 11.00	0.00
LABORER: Roof Tearoff.....	\$ 11.28	0.00

LABORER: Landscape and Irrigation.....	\$ 8.00	0.00
OPERATOR:		
Backhoe/Excavator/Trackhoe.....	\$ 15.98	0.00
OPERATOR: Bobcat/Skid		
Steer/Skid Loader.....	\$ 14.00	0.00
OPERATOR: Bulldozer.....	\$ 14.00	0.00
OPERATOR: Drill.....	\$ 14.50	0.00
OPERATOR: Forklift.....	\$ 12.50	0.00
OPERATOR: Grader/Blade.....	\$ 23.00	5.07
OPERATOR: Loader.....	\$ 12.79	0.00
OPERATOR: Mechanic.....	\$ 18.75	5.12
OPERATOR: Paver (Asphalt, Aggregate, and Concrete).....		
	\$ 16.03	0.00
OPERATOR: Roller.....	\$ 12.00	0.00
PAINTER (Brush, Roller and Spray), Excludes Drywall Finishing/Taping.....		
	\$ 13.07	0.00
ROOFER.....	\$ 12.00	0.00
TILE FINISHER.....	\$ 11.32	0.00
TILE SETTER.....	\$ 14.94	0.00
TRUCK DRIVER: Dump Truck.....	\$ 12.39	1.18
TRUCK DRIVER: Flatbed Truck.....	\$ 19.65	8.57
TRUCK DRIVER: Semi-Trailer Truck.....	\$ 12.50	0.00
TRUCK DRIVER: Water Truck.....	\$ 12.00	4.11

-----

WELDERS - Receive rate prescribed for craft performing operation to which welding is incidental.

=====

Note: Executive Order (EO) 13706, Establishing Paid Sick Leave for Federal Contractors applies to all contracts subject to the Davis-Bacon Act for which the contract is awarded (and any solicitation was issued) on or after January 1, 2017. If this contract is covered by the EO, the contractor must provide employees with 1 hour of paid sick leave for every 30 hours

they work, up to 56 hours of paid sick leave each year. Employees must be permitted to use paid sick leave for their own illness, injury or other health-related needs, including preventive care; to assist a family member (or person who is like family to the employee) who is ill, injured, or has other health-related needs, including preventive care; or for reasons resulting from, or to assist a family member (or person who is like family to the employee) who is a victim of, domestic violence, sexual assault, or stalking. Additional information on contractor requirements and worker protections under the EO is available at [www.dol.gov/whd/govcontracts](http://www.dol.gov/whd/govcontracts).

Unlisted classifications needed for work not included within the scope of the classifications listed may be added after award only as provided in the labor standards contract clauses (29CFR 5.5 (a) (1) (ii)).

-----

The body of each wage determination lists the classification and wage rates that have been found to be prevailing for the cited type(s) of construction in the area covered by the wage determination. The classifications are listed in alphabetical order of ""identifiers"" that indicate whether the particular rate is a union rate (current union negotiated rate for local), a survey rate (weighted average rate) or a union average rate (weighted union average rate).

#### Union Rate Identifiers

A four letter classification abbreviation identifier enclosed in dotted lines beginning with characters other than ""SU"" or ""UAVG"" denotes that the union classification and rate were prevailing for that classification in the survey. Example: PLUM0198-005 07/01/2014. PLUM is an abbreviation identifier of the union which prevailed in the survey for this classification, which in this example would be Plumbers. 0198 indicates the local union number or district council number where applicable, i.e., Plumbers Local 0198. The next number, 005 in the example, is an internal number used in processing the wage determination. 07/01/2014 is the effective date of the most current negotiated rate, which in this example is July 1, 2014.

Union prevailing wage rates are updated to reflect all rate changes in the collective bargaining agreement (CBA) governing this classification and rate.

#### Survey Rate Identifiers

Classifications listed under the ""SU"" identifier indicate that no one rate prevailed for this classification in the survey and the published rate is derived by computing a weighted average rate based on all the rates reported in the survey for that classification. As this weighted average rate includes all rates reported in the survey, it may include both union and non-union rates. Example: SULA2012-007 5/13/2014. SU indicates the rates are survey rates based on a weighted average calculation of rates and are not majority rates. LA indicates the State of Louisiana. 2012 is the year of survey on which these classifications and rates are based. The next number, 007 in the example, is an internal number used in producing the wage determination. 5/13/2014 indicates the survey completion date for the classifications and rates under that identifier.

Survey wage rates are not updated and remain in effect until a new survey is conducted.

#### Union Average Rate Identifiers

Classification(s) listed under the UAVG identifier indicate that no single majority rate prevailed for those classifications; however, 100% of the data reported for the classifications was union data. EXAMPLE: UAVG-OH-0010 08/29/2014. UAVG indicates that the rate is a weighted union average rate. OH indicates the state. The next number, 0010 in the example, is an internal number used in producing the wage determination. 08/29/2014 indicates the survey completion date for the classifications and rates under that identifier.

A UAVG rate will be updated once a year, usually in January of each year, to reflect a weighted average of the current negotiated/CBA rate of the union locals from which the rate is based.

---

## WAGE DETERMINATION APPEALS PROCESS

1.) Has there been an initial decision in the matter? This can be:

- \* an existing published wage determination
- \* a survey underlying a wage determination
- \* a Wage and Hour Division letter setting forth a position on a wage determination matter
- \* a conformance (additional classification and rate) ruling

On survey related matters, initial contact, including requests for summaries of surveys, should be with the Wage and Hour Regional Office for the area in which the survey was conducted because those Regional Offices have responsibility for the Davis-Bacon survey program. If the response from this initial contact is not satisfactory, then the process described in 2.) and 3.) should be followed.

With regard to any other matter not yet ripe for the formal process described here, initial contact should be with the Branch of Construction Wage Determinations. Write to:

Branch of Construction Wage Determinations  
Wage and Hour Division  
U.S. Department of Labor  
200 Constitution Avenue, N.W.  
Washington, DC 20210

2.) If the answer to the question in 1.) is yes, then an interested party (those affected by the action) can request review and reconsideration from the Wage and Hour Administrator (See 29 CFR Part 1.8 and 29 CFR Part 7). Write to:

Wage and Hour Administrator  
U.S. Department of Labor  
200 Constitution Avenue, N.W.  
Washington, DC 20210

The request should be accompanied by a full statement of the interested party's position and by any information (wage payment data, project description, area practice material, etc.) that the requestor considers relevant to the issue.

3.) If the decision of the Administrator is not favorable, an interested party may appeal directly to the Administrative Review Board (formerly the Wage Appeals Board). Write to:

Administrative Review Board  
U.S. Department of Labor  
200 Constitution Avenue, N.W.  
Washington, DC 20210

4.) All decisions by the Administrative Review Board are final.

=====

END OF GENERAL DECISION"

<https://beta.sam.gov/wage-determination/TX20200231/1#document>

## EXHIBIT A-4

### REQUIRED DBRA JOB SITE NOTICE

The Contractor is required to post copies of this wage rate schedule in a prominent, easily accessible place at the work site. If a worker determines that wages paid are not in compliance with wage rates required for the appropriate classification, he or she should report the discrepancy to the Ethics Hotline, phone 1-866-294-3696, <http://www.ethicspoint.com>.

Additionally, the following statement shall be posted beside the wage determination schedule in English and Spanish:

"All complaints of violations by your employer in not paying the posted wage rates for the type of work you do should be reported to the Ethics Hotline, phone 1-866-294-3696, <http://www.ethicspoint.com>. No employee who files a complaint concerning underpayment of wages shall be discharged or in other manner be discriminated against by the Contractor for filing a complaint."

### ANNUNCIO PARA EMPLEADOS DE CONTRATISTAS

"Toda queja de injusticias cometidas por el contratista por no pagar el sueldo establecido segun el tipo de trabajo que Ud. haga, se debe reportar a Ethics Hotline, phone 1-866-294-3696, <http://www.ethicspoint.com>.

Ningun empleado que registre quejas referentes a irregularidades en su sueldo sera discriminado o despedido por el contratista/jefe por registrar la queja.

**EXHIBIT A-5  
CRIMINAL BACKGROUND CHECK CERTIFICATION**

The undersigned, on behalf of Contractor hereby certified to Owner that for the employees listed below, (i) a background check, (ii) an OFAC (Office of Foreign Asset Control) List check, and (iii) a check to affirm that employees' name and social security number match has been completed.

For each name listed below, Contractor hereby certified there are no felony convictions, OFAC List matches, OFAC sanction violations or unmatched Social Security numbers with names.

The undersigned further certifies that he/she is unaware of any denial of an application for a fidelity bond for such individuals.

<b>EMPLOYEE NAME</b>	<b>LAST FOUR DIGITS OF SOCIAL SECURITY NO.</b>	<b>DATE OF BIRTH</b>	<b>ADDRESS (home and mailing if different)</b>

Signature: \_\_\_\_\_

Printed Name: \_\_\_\_\_

Title: \_\_\_\_\_

# Exhibit B

[District's request for proposal and Contractor's Proposal, if any or if attached hereto, as well as any special pricing or payment attachment]



## EXHIBIT A-6

### EDA PROJECT SIGN

The Contractor shall supply, erect, and maintain in good condition a project sign according to the specifications set forth below:

#### EDA SITE SIGN SPECIFICATIONS

Size: 4' x 8' x ¾"

Materials: Exterior grade/MDO plywood (APA rating A-B)

Supports: 4" x 4" x 12' posts with 2" x 4" cross branching

Erection: Posts shall be set a minimum of three feet deep in concrete footings that are at least 12" in diameter.

Paint: Outdoor enamel

Colors: Jet Black, Blue (PMS300), and Gold (PMS7406). Specifically, on white background the following will be placed:

The U. S. Department of Commerce seal in blue, black, and gold;

“EDA” in blue;

“U. S. DEPARTMENT OF COMMERCE ECONOMIC DEVELOPMENT

ADMINISTRATION” in black;

“In partnership with” in blue;

(Actual name of the) “EDA Grant Recipient” in black;

Lettering: Specific fonts are named below; positioning will be as shown on the attached illustration.

“U. S. DEPARTMENT OF COMMERCE ECONOMIC DEVELOPMENT  
ADMINISTRATION” use Bank Gothic Medium - **BANK GOTHIC MED**

“In partnership with” use Univers™ 55 Oblique - *Univers 55*

(Name of) “EDA Grant Recipient” use Univers™ Extra Black 85 **Univers 85**

Project signs will not be erected on public highway rights-of-way. If any possibility exists for obstruction to traffic line of sight, the location and height of the sign will be coordinated with the agency responsible for highway or street safety in the area.

The EDA Regional Director may permit modifications to these specifications if they conflict with state law or local ordinances.

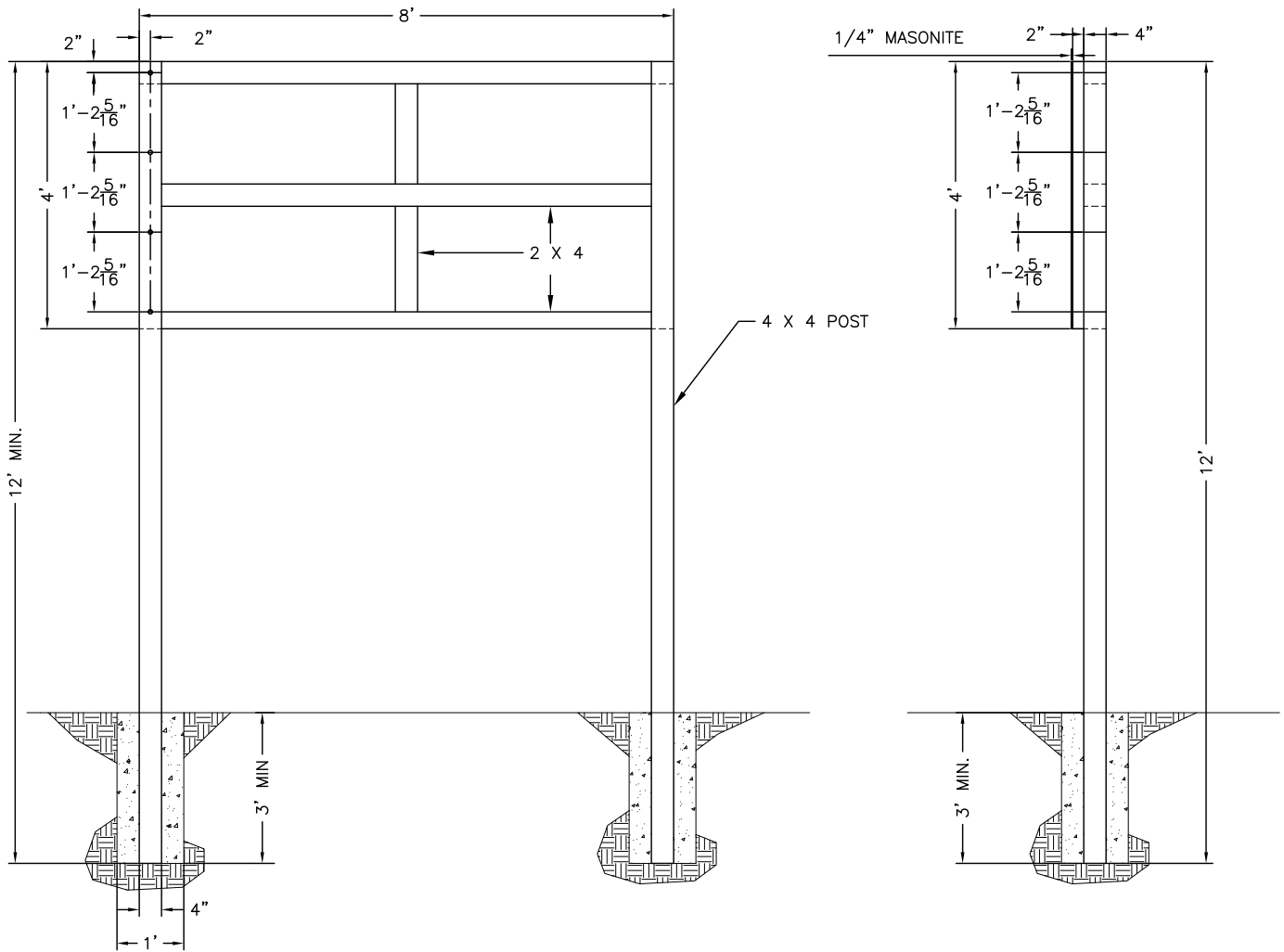

SIGN A  
MASONITE SIGN  
SCALE: 3/8" = 1'

PROJECT - SIGN A

ECONOMIC DEVELOPMENT ADMINISTRATION

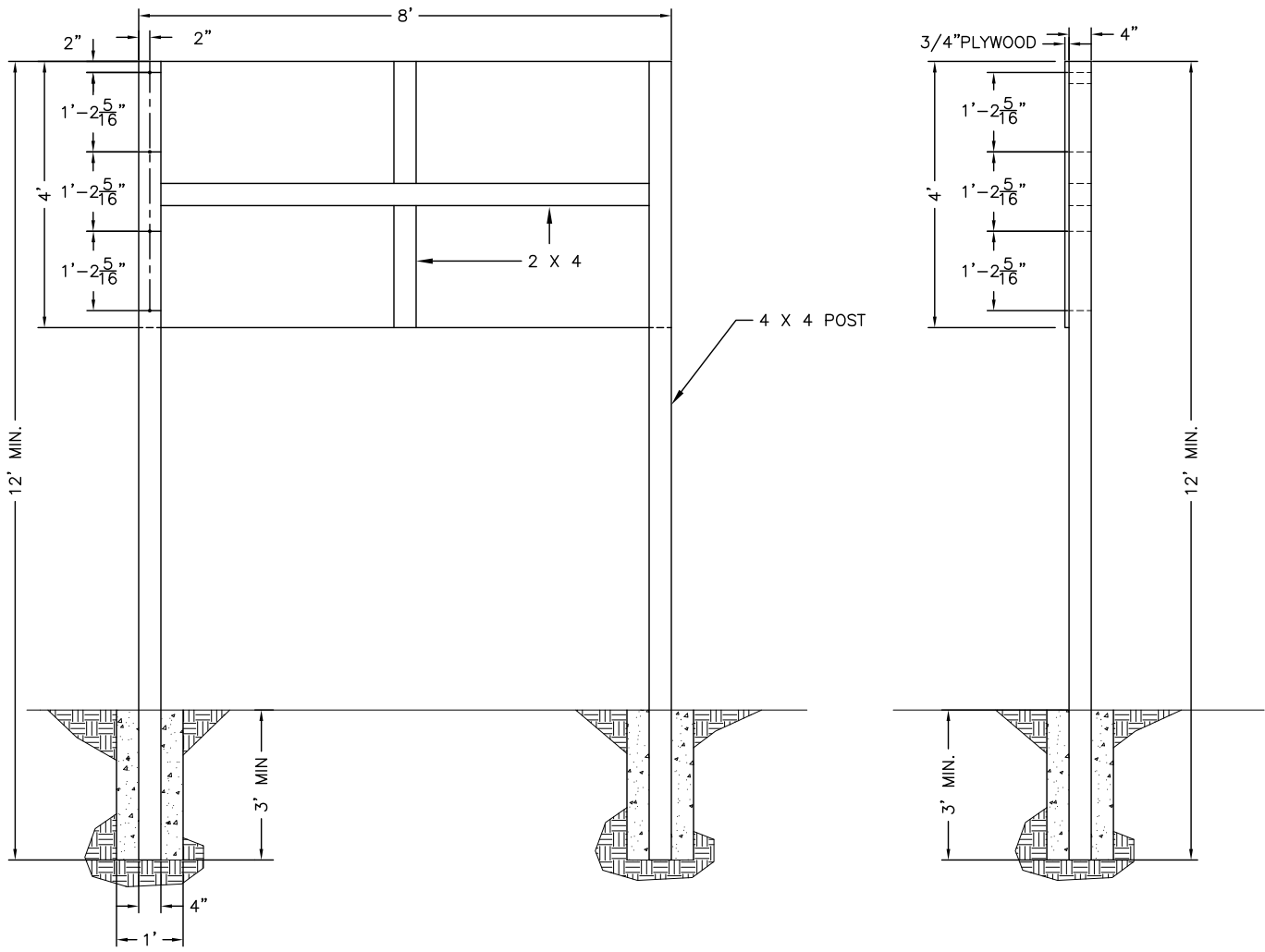

SIGN B  
 PLYWOOD SIGN  
 SCALE: 3/8" = 1'

PROJECT - SIGN B
ECONOMIC DEVELOPMENT ADMINISTRATION



# EDA

U.S. DEPARTMENT OF COMMERCE ECONOMIC DEVELOPMENT ADMINISTRATION

*In partnership with*

**<EDA Grant Recipient Name>**

Black  
Blue= PMS300  
Gold= PMS7406

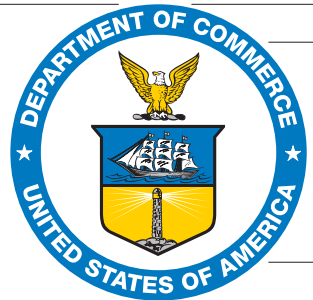

EDA

U.S. DEPARTMENT OF COMMERCE ECONOMIC DEVELOPMENT ADMINISTRATION

*In partnership with*

**<EDA Grant Recipient Name>**

2.25"

13.5"

1.75"

1.75"

10"

2.0"

1.5"

4.0"

3.0"

3.0"

3.75"

15.0"

48"



# AIA® Document A201™ – 2007

## General Conditions of the Contract for Construction

for the following PROJECT:  
(Name and location or address)

THE OWNER:  
(Name, legal status and address)

THE ARCHITECT:  
(Name, legal status and address)

### TABLE OF ARTICLES

1	GENERAL PROVISIONS
2	OWNER
3	CONTRACTOR
4	ARCHITECT
5	SUBCONTRACTORS
6	CONSTRUCTION BY OWNER OR BY SEPARATE CONTRACTORS
7	CHANGES IN THE WORK
8	TIME
9	PAYMENTS AND COMPLETION
10	PROTECTION OF PERSONS AND PROPERTY
11	INSURANCE AND BONDS
12	UNCOVERING AND CORRECTION OF WORK
13	MISCELLANEOUS PROVISIONS
14	TERMINATION OR SUSPENSION OF THE CONTRACT
15	CLAIMS AND DISPUTES

### ADDITIONS AND DELETIONS:

The author of this document has added information needed for its completion. The author may also have revised the text of the original AIA standard form. An *Additions and Deletions Report* that notes added information as well as revisions to the standard form text is available from the author and should be reviewed. A vertical line in the left margin of this document indicates where the author has added necessary information and where the author has added to or deleted from the original AIA text.

This document has important legal consequences. Consultation with an attorney is encouraged with respect to its completion or modification.

## INDEX

(Topics and numbers in bold are section headings.)

### Acceptance of Nonconforming Work

9.6.6, 9.9.3, **12.3**

Acceptance of Work

9.6.6, 9.8.2, 9.9.3, 9.10.1, 9.10.3, **12.3**

### Access to Work

**3.16**, 6.2.1, 12.1

Accident Prevention

10

Acts and Omissions

3.2, 3.3.2, 3.12.8, 3.18, 4.2.3, 8.3.1, 9.5.1, 10.2.5, 10.2.8, 13.4.2, 13.7, 14.1, 15.2

Addenda

1.1.1, 3.11

Additional Costs, Claims for

3.7.4, 3.7.5, 6.1.1, 7.3.7.5, 10.3, 15.1.4

### Additional Inspections and Testing

9.4.2, 9.8.3, 12.2.1, **13.5**

Additional Insured

11.1.4

### Additional Time, Claims for

3.2.4, 3.7.4, 3.7.5, 3.10.2, 8.3.2, **15.1.5**

### Administration of the Contract

3.1.3, **4.2**, 9.4, 9.5

Advertisement or Invitation to Bid

1.1.1

Aesthetic Effect

4.2.13

### Allowances

**3.8**, 7.3.8

All-risk Insurance

11.3.1, 11.3.1.1

### Applications for Payment

4.2.5, 7.3.9, 9.2, **9.3**, 9.4, 9.5.1, 9.6.3, 9.7, 9.10,

11.1.3

Approvals

2.1.1, 2.2.2, 2.4, 3.1.3, 3.10.2, 3.12.8, 3.12.9, 3.12.10,

4.2.7, 9.3.2, 13.5.1

### Arbitration

8.3.1, 11.3.10, 13.1, 15.3.2, **15.4**

## ARCHITECT

**4**

Architect, Definition of

**4.1.1**

Architect, Extent of Authority

2.4, 3.12.7, 4.1, 4.2, 5.2, 6.3, 7.1.2, 7.3.7, 7.4, 9.2, 9.3.1, 9.4, 9.5, 9.6.3, 9.8, 9.10.1, 9.10.3, 12.1, 12.2.1, 13.5.1, 13.5.2, 14.2.2, 14.2.4, 15.1.3, 15.2.1

Architect, Limitations of Authority and Responsibility

2.1.1, 3.12.4, 3.12.8, 3.12.10, 4.1.2, 4.2.1, 4.2.2, 4.2.3, 4.2.6, 4.2.7, 4.2.10, 4.2.12, 4.2.13, 5.2.1, 7.4, 9.4.2, 9.5.3, 9.6.4, 15.1.3, 15.2

Architect's Additional Services and Expenses

2.4, 11.3.1.1, 12.2.1, 13.5.2, 13.5.3, 14.2.4

Architect's Administration of the Contract

3.1.3, 4.2, 3.7.4, 15.2, 9.4.1, 9.5

Architect's Approvals

2.4, 3.1.3, 3.5, 3.10.2, 4.2.7

Architect's Authority to Reject Work

3.5, 4.2.6, 12.1.2, 12.2.1

Architect's Copyright

1.1.7, 1.5

Architect's Decisions

3.7.4, 4.2.6, 4.2.7, 4.2.11, 4.2.12, 4.2.13, 4.2.14, 6.3, 7.3.7, 7.3.9, 8.1.3, 8.3.1, 9.2, 9.4.1, 9.5, 9.8.4, 9.9.1, 13.5.2, 15.2, 15.3

Architect's Inspections

3.7.4, 4.2.2, 4.2.9, 9.4.2, 9.8.3, 9.9.2, 9.10.1, 13.5

Architect's Instructions

3.2.4, 3.3.1, 4.2.6, 4.2.7, 13.5.2

Architect's Interpretations

4.2.11, 4.2.12

Architect's Project Representative

4.2.10

Architect's Relationship with Contractor

1.1.2, 1.5, 3.1.3, 3.2.2, 3.2.3, 3.2.4, 3.3.1, 3.4.2, 3.5, 3.7.4, 3.7.5, 3.9.2, 3.9.3, 3.10, 3.11, 3.12, 3.16, 3.18, 4.1.2, 4.1.3, 4.2, 5.2, 6.2.2, 7, 8.3.1, 9.2, 9.3, 9.4, 9.5, 9.7, 9.8, 9.9, 10.2.6, 10.3, 11.3.7, 12, 13.4.2, 13.5, 15.2

Architect's Relationship with Subcontractors

1.1.2, 4.2.3, 4.2.4, 4.2.6, 9.6.3, 9.6.4, 11.3.7

Architect's Representations

9.4.2, 9.5.1, 9.10.1

Architect's Site Visits

3.7.4, 4.2.2, 4.2.9, 9.4.2, 9.5.1, 9.9.2, 9.10.1, 13.5

Asbestos

10.3.1

Attorneys' Fees

3.18.1, 9.10.2, 10.3.3

Award of Separate Contracts

6.1.1, 6.1.2

### Award of Subcontracts and Other Contracts for Portions of the Work

**5.2**

### Basic Definitions

**1.1**

Bidding Requirements

1.1.1, 5.2.1, 11.4.1

Binding Dispute Resolution

9.7, 11.3.9, 11.3.10, 13.1, 15.2.5, 15.2.6.1, 15.3.1, 15.3.2, 15.4.1

### Boiler and Machinery Insurance

**11.3.2**

Bonds, Lien

7.3.7.4, 9.10.2, 9.10.3

### Bonds, Performance, and Payment

7.3.7.4, 9.6.7, 9.10.3, 11.3.9, **11.4**

Building Permit  
3.7.1

**Capitalization**  
1.3

Certificate of Substantial Completion  
9.8.3, 9.8.4, 9.8.5

**Certificates for Payment**  
4.2.1, 4.2.5, 4.2.9, 9.3.3, 9.4, 9.5, 9.6.1, 9.6.6, 9.7, 9.10.1, 9.10.3, 14.1.1.3, 14.2.4, 15.1.3

Certificates of Inspection, Testing or Approval  
13.5.4

Certificates of Insurance  
9.10.2, 11.1.3

**Change Orders**  
1.1.1, 2.4, 3.4.2, 3.7.4, 3.8.2.3, 3.11, 3.12.8, 4.2.8, 5.2.3, 7.1.2, 7.1.3, 7.2, 7.3.2, 7.3.6, 7.3.9, 7.3.10, 8.3.1, 9.3.1.1, 9.10.3, 10.3.2, 11.3.1.2, 11.3.4, 11.3.9, 12.1.2, 15.1.3

**Change Orders, Definition of**  
7.2.1

**CHANGES IN THE WORK**  
2.2.1, 3.11, 4.2.8, 7, 7.2.1, 7.3.1, 7.4, 8.3.1, 9.3.1.1, 11.3.9

Claims, Definition of  
15.1.1

**CLAIMS AND DISPUTES**  
3.2.4, 6.1.1, 6.3, 7.3.9, 9.3.3, 9.10.4, 10.3.3, 15, 15.4

Claims and Timely Assertion of Claims  
15.4.1

**Claims for Additional Cost**  
3.2.4, 3.7.4, 6.1.1, 7.3.9, 10.3.2, 15.1.4

**Claims for Additional Time**  
3.2.4, 3.7.4, 6.1.1, 8.3.2, 10.3.2, 15.1.5

**Concealed or Unknown Conditions, Claims for**  
3.7.4

Claims for Damages  
3.2.4, 3.18, 6.1.1, 8.3.3, 9.5.1, 9.6.7, 10.3.3, 11.1.1, 11.3.5, 11.3.7, 14.1.3, 14.2.4, 15.1.6

Claims Subject to Arbitration  
15.3.1, 15.4.1

**Cleaning Up**  
3.15, 6.3

Commencement of the Work, Conditions Relating to  
2.2.1, 3.2.2, 3.4.1, 3.7.1, 3.10.1, 3.12.6, 5.2.1, 5.2.3, 6.2.2, 8.1.2, 8.2.2, 8.3.1, 11.1, 11.3.1, 11.3.6, 11.4.1, 15.1.4

**Commencement of the Work, Definition of**  
8.1.2

**Communications Facilitating Contract Administration**  
3.9.1, 4.2.4

Completion, Conditions Relating to  
3.4.1, 3.11, 3.15, 4.2.2, 4.2.9, 8.2, 9.4.2, 9.8, 9.9.1, 9.10, 12.2, 13.7, 14.1.2

**COMPLETION, PAYMENTS AND**  
9

Completion, Substantial  
4.2.9, 8.1.1, 8.1.3, 8.2.3, 9.4.2, 9.8, 9.9.1, 9.10.3, 12.2, 13.7

Compliance with Laws  
1.6, 3.2.3, 3.6, 3.7, 3.12.10, 3.13, 4.1.1, 9.6.4, 10.2.2, 11.1, 11.3, 13.1, 13.4, 13.5.1, 13.5.2, 13.6, 14.1.1, 14.2.1.3, 15.2.8, 15.4.2, 15.4.3

Concealed or Unknown Conditions  
3.7.4, 4.2.8, 8.3.1, 10.3

Conditions of the Contract  
1.1.1, 6.1.1, 6.1.4

Consent, Written  
3.4.2, 3.7.4, 3.12.8, 3.14.2, 4.1.2, 9.3.2, 9.8.5, 9.9.1, 9.10.2, 9.10.3, 11.3.1, 13.2, 13.4.2, 15.4.4.2

**Consolidation or Joinder**  
15.4.4

**CONSTRUCTION BY OWNER OR BY SEPARATE CONTRACTORS**  
1.1.4, 6

**Construction Change Directive, Definition of**  
7.3.1

**Construction Change Directives**  
1.1.1, 3.4.2, 3.12.8, 4.2.8, 7.1.1, 7.1.2, 7.1.3, 7.3, 9.3.1.1

Construction Schedules, Contractor's  
3.10, 3.12.1, 3.12.2, 6.1.3, 15.1.5.2

**Contingent Assignment of Subcontracts**  
5.4, 14.2.2.2

**Continuing Contract Performance**  
15.1.3

**Contract, Definition of**  
1.1.2

**CONTRACT, TERMINATION OR SUSPENSION OF THE**  
5.4.1.1, 11.3.9, 14

Contract Administration  
3.1.3, 4, 9.4, 9.5

Contract Award and Execution, Conditions Relating to  
3.7.1, 3.10, 5.2, 6.1, 11.1.3, 11.3.6, 11.4.1

Contract Documents, Copies Furnished and Use of  
1.5.2, 2.2.5, 5.3

**Contract Documents, Definition of**  
1.1.1

**Contract Sum**  
3.7.4, 3.8, 5.2.3, 7.2, 7.3, 7.4, 9.1, 9.4.2, 9.5.1.4, 9.6.7, 9.7, 10.3.2, 11.3.1, 14.2.4, 14.3.2, 15.1.4, 15.2.5

**Contract Sum, Definition of**  
9.1

Contract Time  
3.7.4, 3.7.5, 3.10.2, 5.2.3, 7.2.1.3, 7.3.1, 7.3.5, 7.4, 8.1.1, 8.2.1, 8.3.1, 9.5.1, 9.7, 10.3.2, 12.1.1, 14.3.2, 15.1.5.1, 15.2.5

**Contract Time, Definition of**  
8.1.1



## CONTRACTOR

3

Contractor, Definition of

3.1, 6.1.2

Contractor's Construction Schedules

3.10, 3.12.1, 3.12.2, 6.1.3, 15.1.5.2

Contractor's Employees

3.3.2, 3.4.3, 3.8.1, 3.9, 3.18.2, 4.2.3, 4.2.6, 10.2, 10.3, 11.1.1, 11.3.7, 14.1, 14.2.1.1

Contractor's Liability Insurance

11.1

Contractor's Relationship with Separate Contractors and Owner's Forces

3.12.5, 3.14.2, 4.2.4, 6, 11.3.7, 12.1.2, 12.2.4

Contractor's Relationship with Subcontractors

1.2.2, 3.3.2, 3.18.1, 3.18.2, 5, 9.6.2, 9.6.7, 9.10.2, 11.3.1.2, 11.3.7, 11.3.8

Contractor's Relationship with the Architect

1.1.2, 1.5, 3.1.3, 3.2.2, 3.2.3, 3.2.4, 3.3.1, 3.4.2, 3.5, 3.7.4, 3.10, 3.11, 3.12, 3.16, 3.18, 4.1.3, 4.2, 5.2, 6.2.2, 7, 8.3.1, 9.2, 9.3, 9.4, 9.5, 9.7, 9.8, 9.9, 10.2.6, 10.3, 11.3.7, 12, 13.5, 15.1.2, 15.2.1

Contractor's Representations

3.2.1, 3.2.2, 3.5, 3.12.6, 6.2.2, 8.2.1, 9.3.3, 9.8.2

Contractor's Responsibility for Those Performing the Work

3.3.2, 3.18, 5.3, 6.1.3, 6.2, 9.5.1, 10.2.8

Contractor's Review of Contract Documents

3.2

Contractor's Right to Stop the Work

9.7

Contractor's Right to Terminate the Contract

14.1, 15.1.6

Contractor's Submittals

3.10, 3.11, 3.12.4, 4.2.7, 5.2.1, 5.2.3, 9.2, 9.3, 9.8.2, 9.8.3, 9.9.1, 9.10.2, 9.10.3, 11.1.3, 11.4.2

Contractor's Superintendent

3.9, 10.2.6

Contractor's Supervision and Construction

Procedures

1.2.2, 3.3, 3.4, 3.12.10, 4.2.2, 4.2.7, 6.1.3, 6.2.4, 7.1.3, 7.3.5, 7.3.7, 8.2, 10, 12, 14, 15.1.3

Contractual Liability Insurance

11.1.1.8, 11.2

Coordination and Correlation

1.2, 3.2.1, 3.3.1, 3.10, 3.12.6, 6.1.3, 6.2.1

Copies Furnished of Drawings and Specifications

1.5, 2.2.5, 3.11

Copyrights

1.5, 3.17

Correction of Work

2.3, 2.4, 3.7.3, 9.4.2, 9.8.2, 9.8.3, 9.9.1, 12.1.2, 12.2

Correlation and Intent of the Contract Documents

1.2

Cost, Definition of

7.3.7

Costs

2.4, 3.2.4, 3.7.3, 3.8.2, 3.15.2, 5.4.2, 6.1.1, 6.2.3, 7.3.3.3, 7.3.7, 7.3.8, 7.3.9, 9.10.2, 10.3.2, 10.3.6, 11.3, 12.1.2, 12.2.1, 12.2.4, 13.5, 14

Cutting and Patching

3.14, 6.2.5

Damage to Construction of Owner or Separate Contractors

3.14.2, 6.2.4, 10.2.1.2, 10.2.5, 10.4, 11.1.1, 11.3, 12.2.4

Damage to the Work

3.14.2, 9.9.1, 10.2.1.2, 10.2.5, 10.4, 11.3.1, 12.2.4

Damages, Claims for

3.2.4, 3.18, 6.1.1, 8.3.3, 9.5.1, 9.6.7, 10.3.3, 11.1.1, 11.3.5, 11.3.7, 14.1.3, 14.2.4, 15.1.6

Damages for Delay

6.1.1, 8.3.3, 9.5.1.6, 9.7, 10.3.2

Date of Commencement of the Work, Definition of

8.1.2

Date of Substantial Completion, Definition of

8.1.3

Day, Definition of

8.1.4

Decisions of the Architect

3.7.4, 4.2.6, 4.2.7, 4.2.11, 4.2.12, 4.2.13, 15.2, 6.3, 7.3.7, 7.3.9, 8.1.3, 8.3.1, 9.2, 9.4, 9.5.1, 9.8.4, 9.9.1, 13.5.2, 14.2.2, 14.2.4, 15.1, 15.2

Decisions to Withhold Certification

9.4.1, 9.5, 9.7, 14.1.1.3

Defective or Nonconforming Work, Acceptance, Rejection and Correction of

2.3, 2.4, 3.5, 4.2.6, 6.2.5, 9.5.1, 9.5.2, 9.6.6, 9.8.2, 9.9.3, 9.10.4, 12.2.1

Definitions

1.1, 2.1.1, 3.1.1, 3.5, 3.12.1, 3.12.2, 3.12.3, 4.1.1, 15.1.1, 5.1, 6.1.2, 7.2.1, 7.3.1, 8.1, 9.1, 9.8.1

Delays and Extensions of Time

3.2, 3.7.4, 5.2.3, 7.2.1, 7.3.1, 7.4, 8.3, 9.5.1, 9.7, 10.3.2, 10.4, 14.3.2, 15.1.5, 15.2.5

Disputes

6.3, 7.3.9, 15.1, 15.2

Documents and Samples at the Site

3.11

Drawings, Definition of

1.1.5

Drawings and Specifications, Use and Ownership of

3.11

Effective Date of Insurance

8.2.2, 11.1.2

Emergencies

10.4, 14.1.1.2, 15.1.4

Employees, Contractor's

3.3.2, 3.4.3, 3.8.1, 3.9, 3.18.2, 4.2.3, 4.2.6, 10.2, 10.3.3, 11.1.1, 11.3.7, 14.1, 14.2.1.1

Init.

Equipment, Labor, Materials or  
 1.1.3, 1.1.6, 3.4, 3.5, 3.8.2, 3.8.3, 3.12, 3.13, 3.15.1,  
 4.2.6, 4.2.7, 5.2.1, 6.2.1, 7.3.7, 9.3.2, 9.3.3, 9.5.1.3,  
 9.10.2, 10.2.1, 10.2.4, 14.2.1.1, 14.2.1.2  
**Execution and Progress of the Work**  
 1.1.3, 1.2.1, 1.2.2, 2.2.3, 2.2.5, 3.1, 3.3.1, 3.4.1, 3.5,  
 3.7.1, 3.10.1, 3.12, 3.14, 4.2, 6.2.2, 7.1.3, 7.3.5, 8.2,  
 9.5.1, 9.9.1, 10.2, 10.3, 12.2, 14.2, 14.3.1, 15.1.3  
**Extensions of Time**  
 3.2.4, 3.7.4, 5.2.3, 7.2.1, 7.3, 7.4, 9.5.1, 9.7, 10.3.2,  
 10.4, 14.3, 15.1.5, 15.2.5  
**Failure of Payment**  
 9.5.1.3, 9.7, 9.10.2, 13.6, 14.1.1.3, 14.2.1.2  
**Faulty Work**  
 (See Defective or Nonconforming Work)  
**Final Completion and Final Payment**  
 4.2.1, 4.2.9, 9.8.2, 9.10, 11.1.2, 11.1.3, 11.3.1, 11.3.5,  
 12.3, 14.2.4, 14.4.3  
**Financial Arrangements, Owner's**  
 2.2.1, 13.2.2, 14.1.1.4  
**Fire and Extended Coverage Insurance**  
 11.3.1.1  
**GENERAL PROVISIONS**  
**1**  
**Governing Law**  
**13.1**  
 Guarantees (See Warranty)  
**Hazardous Materials**  
 10.2.4, 10.3  
**Identification of Subcontractors and Suppliers**  
 5.2.1  
**Indemnification**  
 3.17, 3.18, 9.10.2, 10.3.3, 10.3.5, 10.3.6, 11.3.1.2,  
 11.3.7  
**Information and Services Required of the Owner**  
 2.1.2, 2.2, 3.2.2, 3.12.4, 3.12.10, 6.1.3, 6.1.4, 6.2.5,  
 9.6.1, 9.6.4, 9.9.2, 9.10.3, 10.3.3, 11.2, 11.4, 13.5.1,  
 13.5.2, 14.1.1.4, 14.1.4, 15.1.3  
**Initial Decision**  
**15.2**  
**Initial Decision Maker, Definition of**  
 1.1.8  
**Initial Decision Maker, Decisions**  
 14.2.2, 14.2.4, 15.2.1, 15.2.2, 15.2.3, 15.2.4, 15.2.5  
**Initial Decision Maker, Extent of Authority**  
 14.2.2, 14.2.4, 15.1.3, 15.2.1, 15.2.2, 15.2.3, 15.2.4,  
 15.2.5  
**Injury or Damage to Person or Property**  
**10.2.8, 10.4**  
**Inspections**  
 3.1.3, 3.3.3, 3.7.1, 4.2.2, 4.2.6, 4.2.9, 9.4.2, 9.8.3,  
 9.9.2, 9.10.1, 12.2.1, 13.5  
**Instructions to Bidders**  
 1.1.1  
**Instructions to the Contractor**  
 3.2.4, 3.3.1, 3.8.1, 5.2.1, 7, 8.2.2, 12, 13.5.2

**Instruments of Service, Definition of**  
**1.1.7**  
**Insurance**  
 3.18.1, 6.1.1, 7.3.7, 9.3.2, 9.8.4, 9.9.1, 9.10.2, 11  
**Insurance, Boiler and Machinery**  
**11.3.2**  
**Insurance, Contractor's Liability**  
**11.1**  
 Insurance, Effective Date of  
 8.2.2, 11.1.2  
**Insurance, Loss of Use**  
**11.3.3**  
**Insurance, Owner's Liability**  
**11.2**  
**Insurance, Property**  
 10.2.5, 11.3  
 Insurance, Stored Materials  
 9.3.2  
**INSURANCE AND BONDS**  
**11**  
 Insurance Companies, Consent to Partial Occupancy  
 9.9.1  
 Intent of the Contract Documents  
 1.2.1, 4.2.7, 4.2.12, 4.2.13, 7.4  
**Interest**  
**13.6**  
**Interpretation**  
 1.2.3, 1.4, 4.1.1, 5.1, 6.1.2, 15.1.1  
 Interpretations, Written  
 4.2.11, 4.2.12, 15.1.4  
 Judgment on Final Award  
 15.4.2  
**Labor and Materials, Equipment**  
 1.1.3, 1.1.6, 3.4, 3.5, 3.8.2, 3.8.3, 3.12, 3.13, 3.15.1,  
 4.2.6, 4.2.7, 5.2.1, 6.2.1, 7.3.7, 9.3.2, 9.3.3, 9.5.1.3,  
 9.10.2, 10.2.1, 10.2.4, 14.2.1.1, 14.2.1.2  
**Labor Disputes**  
 8.3.1  
**Laws and Regulations**  
 1.5, 3.2.3, 3.6, 3.7, 3.12.10, 3.13, 4.1.1, 9.6.4, 9.9.1,  
 10.2.2, 11.1.1, 11.3, 13.1, 13.4, 13.5.1, 13.5.2, 13.6,  
 14, 15.2.8, 15.4  
**Liens**  
 2.1.2, 9.3.3, 9.10.2, 9.10.4, 15.2.8  
**Limitations, Statutes of**  
 12.2.5, 13.7, 15.4.1.1  
**Limitations of Liability**  
 2.3, 3.2.2, 3.5, 3.12.10, 3.17, 3.18.1, 4.2.6, 4.2.7,  
 4.2.12, 6.2.2, 9.4.2, 9.6.4, 9.6.7, 10.2.5, 10.3.3,  
 11.1.2, 11.2, 11.3.7, 12.2.5, 13.4.2  
**Limitations of Time**  
 2.1.2, 2.2, 2.4, 3.2.2, 3.10, 3.11, 3.12.5, 3.15.1, 4.2.7,  
 5.2, 5.3, 5.4.1, 6.2.4, 7.3, 7.4, 8.2, 9.2, 9.3.1, 9.3.3,  
 9.4.1, 9.5, 9.6, 9.7, 9.8, 9.9, 9.10, 11.1.3, 11.3.1.5,  
 11.3.6, 11.3.10, 12.2, 13.5, 13.7, 14, 15  
**Loss of Use Insurance**  
**11.3.3**

Init.

Material Suppliers  
1.5, 3.12.1, 4.2.4, 4.2.6, 5.2.1, 9.3, 9.4.2, 9.6, 9.10.5

**Materials, Hazardous**  
10.2.4, **10.3**

Materials, Labor, Equipment and  
1.1.3, 1.1.6, 1.5.1, 3.4.1, 3.5, 3.8.2, 3.8.3, 3.12, 3.13,  
3.15.1, 4.2.6, 4.2.7, 5.2.1, 6.2.1, 7.3.7, 9.3.2, 9.3.3,  
9.5.1.3, 9.10.2, 10.2.1.2, 10.2.4, 14.2.1.1, 14.2.1.2

Means, Methods, Techniques, Sequences and  
Procedures of Construction  
3.3.1, 3.12.10, 4.2.2, 4.2.7, 9.4.2

Mechanic's Lien  
2.1.2, 15.2.8

**Mediation**  
8.3.1, 10.3.5, 10.3.6, 15.2.1, 15.2.5, 15.2.6, **15.3**,  
15.4.1

**Minor Changes in the Work**  
1.1.1, 3.12.8, 4.2.8, 7.1, **7.4**

**MISCELLANEOUS PROVISIONS**  
**13**

**Modifications, Definition of**  
**1.1.1**  
Modifications to the Contract  
1.1.1, 1.1.2, 3.11, 4.1.2, 4.2.1, 5.2.3, 7, 8.3.1, 9.7,  
10.3.2, 11.3.1

**Mutual Responsibility**  
**6.2**

**Nonconforming Work, Acceptance of**  
9.6.6, 9.9.3, **12.3**  
Nonconforming Work, Rejection and Correction of  
2.3, 2.4, 3.5, 4.2.6, 6.2.4, 9.5.1, 9.8.2, 9.9.3, 9.10.4,  
12.2.1  
Notice  
2.2.1, 2.3, 2.4, 3.2.4, 3.3.1, 3.7.2, 3.12.9, 5.2.1, 9.7,  
9.10, 10.2.2, 11.1.3, 12.2.2.1, 13.3, 13.5.1, 13.5.2,  
14.1, 14.2, 15.2.8, 15.4.1

**Notice, Written**  
2.3, 2.4, 3.3.1, 3.9.2, 3.12.9, 3.12.10, 5.2.1, 9.7, 9.10,  
10.2.2, 10.3, 11.1.3, 11.3.6, 12.2.2.1, **13.3**, 14, 15.2.8,  
15.4.1

**Notice of Claims**  
3.7.4, 10.2.8, **15.1.2**, 15.4

Notice of Testing and Inspections  
13.5.1, 13.5.2

Observations, Contractor's  
3.2, 3.7.4

Occupancy  
2.2.2, 9.6.6, 9.8, 11.3.1.5

Orders, Written  
1.1.1, 2.3, 3.9.2, 7, 8.2.2, 11.3.9, 12.1, 12.2.2.1,  
13.5.2, 14.3.1

**OWNER**  
**2**

**Owner, Definition of**  
**2.1.1**

**Owner, Information and Services Required of the**  
2.1.2, **2.2**, 3.2.2, 3.12.10, 6.1.3, 6.1.4, 6.2.5, 9.3.2,  
9.6.1, 9.6.4, 9.9.2, 9.10.3, 10.3.3, 11.2, 11.3, 13.5.1,  
13.5.2, 14.1.1.4, 14.1.4, 15.1.3

**Owner's Authority**  
1.5, 2.1.1, 2.3, 2.4, 3.4.2, 3.8.1, 3.12.10, 3.14.2, 4.1.2,  
4.1.3, 4.2.4, 4.2.9, 5.2.1, 5.2.4, 5.4.1, 6.1, 6.3, 7.2.1,  
7.3.1, 8.2.2, 8.3.1, 9.3.1, 9.3.2, 9.5.1, 9.6.4, 9.9.1,  
9.10.2, 10.3.2, 11.1.3, 11.3.3, 11.3.10, 12.2.2, 12.3,  
13.2.2, 14.3, 14.4, 15.2.7

**Owner's Financial Capability**  
2.2.1, 13.2.2, 14.1.1.4

**Owner's Liability Insurance**  
**11.2**  
**Owner's Relationship with Subcontractors**  
1.1.2, 5.2, 5.3, 5.4, 9.6.4, 9.10.2, 14.2.2

**Owner's Right to Carry Out the Work**  
2.4, 14.2.2

**Owner's Right to Clean Up**  
**6.3**

**Owner's Right to Perform Construction and to Award Separate Contracts**  
**6.1**

**Owner's Right to Stop the Work**  
**2.3**  
**Owner's Right to Suspend the Work**  
14.3

**Owner's Right to Terminate the Contract**  
14.2

**Ownership and Use of Drawings, Specifications and Other Instruments of Service**  
1.1.1, 1.1.6, 1.1.7, **1.5**, 2.2.5, 3.2.2, 3.11, 3.17, 4.2.12,  
5.3

**Partial Occupancy or Use**  
9.6.6, **9.9**, 11.3.1.5

**Patching, Cutting and**  
**3.14**, 6.2.5

Patents  
3.17

**Payment, Applications for**  
4.2.5, 7.3.9, 9.2, **9.3**, 9.4, 9.5, 9.6.3, 9.7, 9.8.5, 9.10.1,  
14.2.3, 14.2.4, 14.4.3

**Payment, Certificates for**  
4.2.5, 4.2.9, 9.3.3, **9.4**, 9.5, 9.6.1, 9.6.6, 9.7, 9.10.1,  
9.10.3, 13.7, 14.1.1.3, 14.2.4

**Payment, Failure of**  
9.5.1.3, **9.7**, 9.10.2, 13.6, 14.1.1.3, 14.2.1.2

Payment, Final  
4.2.1, 4.2.9, 9.8.2, 9.10, 11.1.2, 11.1.3, 11.4.1, 12.3,  
13.7, 14.2.4, 14.4.3

**Payment Bond, Performance Bond and**  
7.3.7.4, 9.6.7, 9.10.3, **11.4**

**Payments, Progress**  
9.3, **9.6**, 9.8.5, 9.10.3, 13.6, 14.2.3, 15.1.3

**PAYMENTS AND COMPLETION**  
**9**

Init.

**Payments to Subcontractors**  
 5.4.2, 9.5.1.3, 9.6.2, 9.6.3, 9.6.4, 9.6.7, 14.2.1.2  
**PCB**  
 10.3.1  
**Performance Bond and Payment Bond**  
 7.3.7.4, 9.6.7, 9.10.3, 11.4  
**Permits, Fees, Notices and Compliance with Laws**  
 2.2.2, 3.7, 3.13, 7.3.7.4, 10.2.2  
**PERSONS AND PROPERTY, PROTECTION OF**  
**10**  
**Polychlorinated Biphenyl**  
 10.3.1  
**Product Data, Definition of**  
**3.12.2**  
**Product Data and Samples, Shop Drawings**  
 3.11, 3.12, 4.2.7  
**Progress and Completion**  
 4.2.2, 8.2, 9.8, 9.9.1, 14.1.4, 15.1.3  
**Progress Payments**  
 9.3, 9.6, 9.8.5, 9.10.3, 13.6, 14.2.3, 15.1.3  
**Project, Definition of**  
**1.1.4**  
**Project Representatives**  
 4.2.10  
**Property Insurance**  
 10.2.5, 11.3  
**PROTECTION OF PERSONS AND PROPERTY**  
**10**  
**Regulations and Laws**  
 1.5, 3.2.3, 3.6, 3.7, 3.12.10, 3.13, 4.1.1, 9.6.4, 9.9.1, 10.2.2, 11.1, 11.4, 13.1, 13.4, 13.5.1, 13.5.2, 13.6, 14, 15.2.8, 15.4  
**Rejection of Work**  
 3.5, 4.2.6, 12.2.1  
**Releases and Waivers of Liens**  
 9.10.2  
**Representations**  
 3.2.1, 3.5, 3.12.6, 6.2.2, 8.2.1, 9.3.3, 9.4.2, 9.5.1, 9.8.2, 9.10.1  
**Representatives**  
 2.1.1, 3.1.1, 3.9, 4.1.1, 4.2.1, 4.2.2, 4.2.10, 5.1.1, 5.1.2, 13.2.1  
**Responsibility for Those Performing the Work**  
 3.3.2, 3.18, 4.2.3, 5.3, 6.1.3, 6.2, 6.3, 9.5.1, 10  
**Retainage**  
 9.3.1, 9.6.2, 9.8.5, 9.9.1, 9.10.2, 9.10.3  
**Review of Contract Documents and Field Conditions by Contractor**  
**3.2, 3.12.7, 6.1.3**  
**Review of Contractor's Submittals by Owner and Architect**  
 3.10.1, 3.10.2, 3.11, 3.12, 4.2, 5.2, 6.1.3, 9.2, 9.8.2  
**Review of Shop Drawings, Product Data and Samples by Contractor**  
 3.12

**Rights and Remedies**  
 1.1.2, 2.3, 2.4, 3.5, 3.7.4, 3.15.2, 4.2.6, 5.3, 5.4, 6.1, 6.3, 7.3.1, 8.3, 9.5.1, 9.7, 10.2.5, 10.3, 12.2.2, 12.2.4, 13.4, 14, 15.4  
**Royalties, Patents and Copyrights**  
**3.17**  
**Rules and Notices for Arbitration**  
 15.4.1  
**Safety of Persons and Property**  
**10.2, 10.4**  
**Safety Precautions and Programs**  
 3.3.1, 4.2.2, 4.2.7, 5.3, 10.1, 10.2, 10.4  
**Samples, Definition of**  
**3.12.3**  
**Samples, Shop Drawings, Product Data and**  
 3.11, 3.12, 4.2.7  
**Samples at the Site, Documents and**  
**3.11**  
**Schedule of Values**  
**9.2, 9.3.1**  
**Schedules, Construction**  
 3.10, 3.12.1, 3.12.2, 6.1.3, 15.1.5.2  
**Separate Contracts and Contractors**  
 1.1.4, 3.12.5, 3.14.2, 4.2.4, 4.2.7, 6, 8.3.1, 12.1.2  
**Shop Drawings, Definition of**  
**3.12.1**  
**Shop Drawings, Product Data and Samples**  
 3.11, 3.12, 4.2.7  
**Site, Use of**  
**3.13, 6.1.1, 6.2.1**  
**Site Inspections**  
 3.2.2, 3.3.3, 3.7.1, 3.7.4, 4.2, 9.4.2, 9.10.1, 13.5  
**Site Visits, Architect's**  
 3.7.4, 4.2.2, 4.2.9, 9.4.2, 9.5.1, 9.9.2, 9.10.1, 13.5  
**Special Inspections and Testing**  
 4.2.6, 12.2.1, 13.5  
**Specifications, Definition of**  
**1.1.6**  
**Specifications**  
 1.1.1, 1.1.6, 1.2.2, 1.5, 3.11, 3.12.10, 3.17, 4.2.14  
**Statute of Limitations**  
 13.7, 15.4.1.1  
**Stopping the Work**  
 2.3, 9.7, 10.3, 14.1  
**Stored Materials**  
 6.2.1, 9.3.2, 10.2.1.2, 10.2.4  
**Subcontractor, Definition of**  
**5.1.1**  
**SUBCONTRACTORS**  
**5**  
**Subcontractors, Work by**  
 1.2.2, 3.3.2, 3.12.1, 4.2.3, 5.2.3, 5.3, 5.4, 9.3.1.2, 9.6.7  
**Subcontractual Relations**  
**5.3, 5.4, 9.3.1.2, 9.6, 9.10, 10.2.1, 14.1, 14.2.1**



**Submittals**  
 3.10, 3.11, 3.12, 4.2.7, 5.2.1, 5.2.3, 7.3.7, 9.2, 9.3, 9.8, 9.9.1, 9.10.2, 9.10.3, 11.1.3  
**Submittal Schedule**  
 3.10.2, 3.12.5, 4.2.7  
**Subrogation, Waivers of**  
 6.1.1, 11.3.7  
**Substantial Completion**  
 4.2.9, 8.1.1, 8.1.3, 8.2.3, 9.4.2, 9.8, 9.9.1, 9.10.3, 12.2, 13.7  
**Substantial Completion, Definition of**  
**9.8.1**  
**Substitution of Subcontractors**  
 5.2.3, 5.2.4  
**Substitution of Architect**  
 4.1.3  
**Substitutions of Materials**  
 3.4.2, 3.5, 7.3.8  
**Sub-subcontractor, Definition of**  
**5.1.2**  
**Subsurface Conditions**  
 3.7.4  
**Successors and Assigns**  
**13.2**  
**Superintendent**  
 3.9, 10.2.6  
**Supervision and Construction Procedures**  
 1.2.2, 3.3, 3.4, 3.12.10, 4.2.2, 4.2.7, 6.1.3, 6.2.4, 7.1.3, 7.3.7, 8.2, 8.3.1, 9.4.2, 10, 12, 14, 15.1.3  
**Surety**  
 5.4.1.2, 9.8.5, 9.10.2, 9.10.3, 14.2.2, 15.2.7  
**Surety, Consent of**  
 9.10.2, 9.10.3  
**Surveys**  
 2.2.3  
**Suspension by the Owner for Convenience**  
**14.3**  
**Suspension of the Work**  
 5.4.2, 14.3  
**Suspension or Termination of the Contract**  
 5.4.1.1, 14  
**Taxes**  
 3.6, 3.8.2.1, 7.3.7.4  
**Termination by the Contractor**  
 14.1, 15.1.6  
**Termination by the Owner for Cause**  
 5.4.1.1, 14.2, 15.1.6  
**Termination by the Owner for Convenience**  
**14.4**  
**Termination of the Architect**  
 4.1.3  
**Termination of the Contractor**  
 14.2.2  
**TERMINATION OR SUSPENSION OF THE CONTRACT**  
**14**

**Tests and Inspections**  
 3.1.3, 3.3.3, 4.2.2, 4.2.6, 4.2.9, 9.4.2, 9.8.3, 9.9.2, 9.10.1, 10.3.2, 11.4.1, 12.2.1, 13.5  
**TIME**  
**8**  
**Time, Delays and Extensions of**  
 3.2.4, 3.7.4, 5.2.3, 7.2.1, 7.3.1, 7.4, 8.3, 9.5.1, 9.7, 10.3.2, 10.4, 14.3.2, 15.1.5, 15.2.5  
**Time Limits**  
 2.1.2, 2.2, 2.4, 3.2.2, 3.10, 3.11, 3.12.5, 3.15.1, 4.2, 5.2, 5.3, 5.4, 6.2.4, 7.3, 7.4, 8.2, 9.2, 9.3.1, 9.3.3, 9.4.1, 9.5, 9.6, 9.7, 9.8, 9.9, 9.10, 11.1.3, 12.2, 13.5, 13.7, 14, 15.1.2, 15.4  
**Time Limits on Claims**  
 3.7.4, 10.2.8, 13.7, 15.1.2  
**Title to Work**  
 9.3.2, 9.3.3  
**Transmission of Data in Digital Form**  
**1.6**  
**UNCOVERING AND CORRECTION OF WORK**  
**12**  
**Uncovering of Work**  
**12.1**  
**Unforeseen Conditions, Concealed or Unknown**  
 3.7.4, 8.3.1, 10.3  
**Unit Prices**  
 7.3.3.2, 7.3.4  
**Use of Documents**  
 1.1.1, 1.5, 2.2.5, 3.12.6, 5.3  
**Use of Site**  
**3.13, 6.1.1, 6.2.1**  
**Values, Schedule of**  
**9.2, 9.3.1**  
**Waiver of Claims by the Architect**  
 13.4.2  
**Waiver of Claims by the Contractor**  
 9.10.5, 13.4.2, 15.1.6  
**Waiver of Claims by the Owner**  
 9.9.3, 9.10.3, 9.10.4, 12.2.2.1, 13.4.2, 14.2.4, 15.1.6  
**Waiver of Consequential Damages**  
 14.2.4, 15.1.6  
**Waiver of Liens**  
 9.10.2, 9.10.4  
**Waivers of Subrogation**  
 6.1.1, 11.3.7  
**Warranty**  
 3.5, 4.2.9, 9.3.3, 9.8.4, 9.9.1, 9.10.4, 12.2.2, 13.7  
**Weather Delays**  
 15.1.5.2  
**Work, Definition of**  
**1.1.3**  
**Written Consent**  
 1.5.2, 3.4.2, 3.7.4, 3.12.8, 3.14.2, 4.1.2, 9.3.2, 9.8.5, 9.9.1, 9.10.2, 9.10.3, 11.4.1, 13.2, 13.4.2, 15.4.4.2  
**Written Interpretations**  
 4.2.11, 4.2.12

Written Notice

2.3, 2.4, 3.3.1, 3.9, 3.12.9, 3.12.10, 5.2.1, 8.2.2, 9.7,  
9.10, 10.2.2, 10.3, 11.1.3, 12.2.2, 12.2.4, 13.3, 14,  
15.4.1

Written Orders

1.1.1, 2.3, 3.9, 7, 8.2.2, 12.1, 12.2, 13.5.2, 14.3.1,  
15.1.2

Init.

## ARTICLE 1 GENERAL PROVISIONS

### § 1.1 BASIC DEFINITIONS

#### § 1.1.1 THE CONTRACT DOCUMENTS

The Contract Documents are enumerated in the Agreement between the Owner and Contractor (hereinafter the Agreement) and consist of the Agreement, Conditions of the Contract (General, Supplementary and other Conditions), Drawings, Specifications, Addenda issued prior to execution of the Contract, other documents listed in the Agreement and Modifications issued after execution of the Contract. A Modification is (1) a written amendment to the Contract signed by both parties, (2) a Change Order, (3) a Construction Change Directive or (4) a written order for a minor change in the Work issued by the Architect. Unless specifically enumerated in the Agreement, the Contract Documents do not include the advertisement or invitation to bid, Instructions to Bidders, sample forms, other information furnished by the Owner in anticipation of receiving bids or proposals, the Contractor's bid or proposal, or portions of Addenda relating to bidding requirements.

#### § 1.1.2 THE CONTRACT

The Contract Documents form the Contract for Construction. The Contract represents the entire and integrated agreement between the parties hereto and supersedes prior negotiations, representations or agreements, either written or oral. The Contract may be amended or modified only by a Modification. The Contract Documents shall not be construed to create a contractual relationship of any kind (1) between the Contractor and the Architect or the Architect's consultants, (2) between the Owner and a Subcontractor or a Sub-subcontractor, (3) between the Owner and the Architect or the Architect's consultants or (4) between any persons or entities other than the Owner and the Contractor. The Architect shall, however, be entitled to performance and enforcement of obligations under the Contract intended to facilitate performance of the Architect's duties.

#### § 1.1.3 THE WORK

The term "Work" means the construction and services required by the Contract Documents, whether completed or partially completed, and includes all other labor, materials, equipment and services provided or to be provided by the Contractor to fulfill the Contractor's obligations. The Work may constitute the whole or a part of the Project.

#### § 1.1.4 THE PROJECT

The Project is the total construction of which the Work performed under the Contract Documents may be the whole or a part and which may include construction by the Owner and by separate contractors.

#### § 1.1.5 THE DRAWINGS

The Drawings are the graphic and pictorial portions of the Contract Documents showing the design, location and dimensions of the Work, generally including plans, elevations, sections, details, schedules and diagrams.

#### § 1.1.6 THE SPECIFICATIONS

The Specifications are that portion of the Contract Documents consisting of the written requirements for materials, equipment, systems, standards and workmanship for the Work, and performance of related services.

#### § 1.1.7 INSTRUMENTS OF SERVICE

Instruments of Service are representations, in any medium of expression now known or later developed, of the tangible and intangible creative work performed by the Architect and the Architect's consultants under their respective professional services agreements. Instruments of Service may include, without limitation, studies, surveys, models, sketches, drawings, specifications, and other similar materials.

#### § 1.1.8 INITIAL DECISION MAKER

The Initial Decision Maker is the person identified in the Agreement to render initial decisions on Claims in accordance with Section 15.2 and certify termination of the Agreement under Section 14.2.2.

### § 1.2 CORRELATION AND INTENT OF THE CONTRACT DOCUMENTS

§ 1.2.1 The intent of the Contract Documents is to include all items necessary for the proper execution and completion of the Work by the Contractor. The Contract Documents are complementary, and what is required by one shall be as binding as if required by all; performance by the Contractor shall be required only to the extent consistent with the Contract Documents and reasonably inferable from them as being necessary to produce the indicated results.

Init.

§ 1.2.2 Organization of the Specifications into divisions, sections and articles, and arrangement of Drawings shall not control the Contractor in dividing the Work among Subcontractors or in establishing the extent of Work to be performed by any trade.

§ 1.2.3 Unless otherwise stated in the Contract Documents, words that have well-known technical or construction industry meanings are used in the Contract Documents in accordance with such recognized meanings.

### § 1.3 CAPITALIZATION

Terms capitalized in these General Conditions include those that are (1) specifically defined, (2) the titles of numbered articles or (3) the titles of other documents published by the American Institute of Architects.

### § 1.4 INTERPRETATION

In the interest of brevity the Contract Documents frequently omit modifying words such as "all" and "any" and articles such as "the" and "an," but the fact that a modifier or an article is absent from one statement and appears in another is not intended to affect the interpretation of either statement.

### § 1.5 OWNERSHIP AND USE OF DRAWINGS, SPECIFICATIONS AND OTHER INSTRUMENTS OF SERVICE

§ 1.5.1 The Architect and the Architect's consultants shall be deemed the authors and owners of their respective Instruments of Service, including the Drawings and Specifications, and will retain all common law, statutory and other reserved rights, including copyrights. The Contractor, Subcontractors, Sub-subcontractors, and material or equipment suppliers shall not own or claim a copyright in the Instruments of Service. Submittal or distribution to meet official regulatory requirements or for other purposes in connection with this Project is not to be construed as publication in derogation of the Architect's or Architect's consultants' reserved rights.

§ 1.5.2 The Contractor, Subcontractors, Sub-subcontractors and material or equipment suppliers are authorized to use and reproduce the Instruments of Service provided to them solely and exclusively for execution of the Work. All copies made under this authorization shall bear the copyright notice, if any, shown on the Instruments of Service. The Contractor, Subcontractors, Sub-subcontractors, and material or equipment suppliers may not use the Instruments of Service on other projects or for additions to this Project outside the scope of the Work without the specific written consent of the Owner, Architect and the Architect's consultants.

### § 1.6 TRANSMISSION OF DATA IN DIGITAL FORM

If the parties intend to transmit Instruments of Service or any other information or documentation in digital form, they shall endeavor to establish necessary protocols governing such transmissions, unless otherwise already provided in the Agreement or the Contract Documents.

## ARTICLE 2 OWNER

### § 2.1 GENERAL

§ 2.1.1 The Owner is the person or entity identified as such in the Agreement and is referred to throughout the Contract Documents as if singular in number. The Owner shall designate in writing a representative who shall have express authority to bind the Owner with respect to all matters requiring the Owner's approval or authorization. Except as otherwise provided in Section 4.2.1, the Architect does not have such authority. The term "Owner" means the Owner or the Owner's authorized representative.

§ 2.1.2 The Owner shall furnish to the Contractor within fifteen days after receipt of a written request, information necessary and relevant for the Contractor to evaluate, give notice of or enforce mechanic's lien rights. Such information shall include a correct statement of the record legal title to the property on which the Project is located, usually referred to as the site, and the Owner's interest therein.

### § 2.2 INFORMATION AND SERVICES REQUIRED OF THE OWNER

§ 2.2.1 Prior to commencement of the Work, the Contractor may request in writing that the Owner provide reasonable evidence that the Owner has made financial arrangements to fulfill the Owner's obligations under the Contract. Thereafter, the Contractor may only request such evidence if (1) the Owner fails to make payments to the Contractor as the Contract Documents require; (2) a change in the Work materially changes the Contract Sum; or (3) the Contractor identifies in writing a reasonable concern regarding the Owner's ability to make payment when due. The Owner shall furnish such evidence as a condition precedent to commencement or continuation of the Work or



the portion of the Work affected by a material change. After the Owner furnishes the evidence, the Owner shall not materially vary such financial arrangements without prior notice to the Contractor.

§ 2.2.2 Except for permits and fees that are the responsibility of the Contractor under the Contract Documents, including those required under Section 3.7.1, the Owner shall secure and pay for necessary approvals, easements, assessments and charges required for construction, use or occupancy of permanent structures or for permanent changes in existing facilities.

§ 2.2.3 The Owner shall furnish surveys describing physical characteristics, legal limitations and utility locations for the site of the Project, and a legal description of the site. The Contractor shall be entitled to rely on the accuracy of information furnished by the Owner but shall exercise proper precautions relating to the safe performance of the Work.

§ 2.2.4 The Owner shall furnish information or services required of the Owner by the Contract Documents with reasonable promptness. The Owner shall also furnish any other information or services under the Owner's control and relevant to the Contractor's performance of the Work with reasonable promptness after receiving the Contractor's written request for such information or services.

§ 2.2.5 Unless otherwise provided in the Contract Documents, the Owner shall furnish to the Contractor one copy of the Contract Documents for purposes of making reproductions pursuant to Section 1.5.2.

### § 2.3 OWNER'S RIGHT TO STOP THE WORK

If the Contractor fails to correct Work that is not in accordance with the requirements of the Contract Documents as required by Section 12.2 or repeatedly fails to carry out Work in accordance with the Contract Documents, the Owner may issue a written order to the Contractor to stop the Work, or any portion thereof, until the cause for such order has been eliminated; however, the right of the Owner to stop the Work shall not give rise to a duty on the part of the Owner to exercise this right for the benefit of the Contractor or any other person or entity, except to the extent required by Section 6.1.3.

### § 2.4 OWNER'S RIGHT TO CARRY OUT THE WORK

If the Contractor defaults or neglects to carry out the Work in accordance with the Contract Documents and fails within a ten-day period after receipt of written notice from the Owner to commence and continue correction of such default or neglect with diligence and promptness, the Owner may, without prejudice to other remedies the Owner may have, correct such deficiencies. In such case an appropriate Change Order shall be issued deducting from payments then or thereafter due the Contractor the reasonable cost of correcting such deficiencies, including Owner's expenses and compensation for the Architect's additional services made necessary by such default, neglect or failure. Such action by the Owner and amounts charged to the Contractor are both subject to prior approval of the Architect. If payments then or thereafter due the Contractor are not sufficient to cover such amounts, the Contractor shall pay the difference to the Owner.

## ARTICLE 3 CONTRACTOR

### § 3.1 GENERAL

§ 3.1.1 The Contractor is the person or entity identified as such in the Agreement and is referred to throughout the Contract Documents as if singular in number. The Contractor shall be lawfully licensed, if required in the jurisdiction where the Project is located. The Contractor shall designate in writing a representative who shall have express authority to bind the Contractor with respect to all matters under this Contract. The term "Contractor" means the Contractor or the Contractor's authorized representative.

§ 3.1.2 The Contractor shall perform the Work in accordance with the Contract Documents.

§ 3.1.3 The Contractor shall not be relieved of obligations to perform the Work in accordance with the Contract Documents either by activities or duties of the Architect in the Architect's administration of the Contract, or by tests, inspections or approvals required or performed by persons or entities other than the Contractor.

## § 3.2 REVIEW OF CONTRACT DOCUMENTS AND FIELD CONDITIONS BY CONTRACTOR

§ 3.2.1 Execution of the Contract by the Contractor is a representation that the Contractor has visited the site, become generally familiar with local conditions under which the Work is to be performed and correlated personal observations with requirements of the Contract Documents.

§ 3.2.2 Because the Contract Documents are complementary, the Contractor shall, before starting each portion of the Work, carefully study and compare the various Contract Documents relative to that portion of the Work, as well as the information furnished by the Owner pursuant to Section 2.2.3, shall take field measurements of any existing conditions related to that portion of the Work, and shall observe any conditions at the site affecting it. These obligations are for the purpose of facilitating coordination and construction by the Contractor and are not for the purpose of discovering errors, omissions, or inconsistencies in the Contract Documents; however, the Contractor shall promptly report to the Architect any errors, inconsistencies or omissions discovered by or made known to the Contractor as a request for information in such form as the Architect may require. It is recognized that the Contractor's review is made in the Contractor's capacity as a contractor and not as a licensed design professional, unless otherwise specifically provided in the Contract Documents.

§ 3.2.3 The Contractor is not required to ascertain that the Contract Documents are in accordance with applicable laws, statutes, ordinances, codes, rules and regulations, or lawful orders of public authorities, but the Contractor shall promptly report to the Architect any nonconformity discovered by or made known to the Contractor as a request for information in such form as the Architect may require.

§ 3.2.4 If the Contractor believes that additional cost or time is involved because of clarifications or instructions the Architect issues in response to the Contractor's notices or requests for information pursuant to Sections 3.2.2 or 3.2.3, the Contractor shall make Claims as provided in Article 15. If the Contractor fails to perform the obligations of Sections 3.2.2 or 3.2.3, the Contractor shall pay such costs and damages to the Owner as would have been avoided if the Contractor had performed such obligations. If the Contractor performs those obligations, the Contractor shall not be liable to the Owner or Architect for damages resulting from errors, inconsistencies or omissions in the Contract Documents, for differences between field measurements or conditions and the Contract Documents, or for nonconformities of the Contract Documents to applicable laws, statutes, ordinances, codes, rules and regulations, and lawful orders of public authorities.

## § 3.3 SUPERVISION AND CONSTRUCTION PROCEDURES

§ 3.3.1 The Contractor shall supervise and direct the Work, using the Contractor's best skill and attention. The Contractor shall be solely responsible for, and have control over, construction means, methods, techniques, sequences and procedures and for coordinating all portions of the Work under the Contract, unless the Contract Documents give other specific instructions concerning these matters. If the Contract Documents give specific instructions concerning construction means, methods, techniques, sequences or procedures, the Contractor shall evaluate the jobsite safety thereof and, except as stated below, shall be fully and solely responsible for the jobsite safety of such means, methods, techniques, sequences or procedures. If the Contractor determines that such means, methods, techniques, sequences or procedures may not be safe, the Contractor shall give timely written notice to the Owner and Architect and shall not proceed with that portion of the Work without further written instructions from the Architect. If the Contractor is then instructed to proceed with the required means, methods, techniques, sequences or procedures without acceptance of changes proposed by the Contractor, the Owner shall be solely responsible for any loss or damage arising solely from those Owner-required means, methods, techniques, sequences or procedures.

§ 3.3.2 The Contractor shall be responsible to the Owner for acts and omissions of the Contractor's employees, Subcontractors and their agents and employees, and other persons or entities performing portions of the Work for, or on behalf of, the Contractor or any of its Subcontractors.

§ 3.3.3 The Contractor shall be responsible for inspection of portions of Work already performed to determine that such portions are in proper condition to receive subsequent Work.

## § 3.4 LABOR AND MATERIALS

§ 3.4.1 Unless otherwise provided in the Contract Documents, the Contractor shall provide and pay for labor, materials, equipment, tools, construction equipment and machinery, water, heat, utilities, transportation, and other

facilities and services necessary for proper execution and completion of the Work, whether temporary or permanent and whether or not incorporated or to be incorporated in the Work.

§ 3.4.2 Except in the case of minor changes in the Work authorized by the Architect in accordance with Sections 3.12.8 or 7.4, the Contractor may make substitutions only with the consent of the Owner, after evaluation by the Architect and in accordance with a Change Order or Construction Change Directive.

§ 3.4.3 The Contractor shall enforce strict discipline and good order among the Contractor's employees and other persons carrying out the Work. The Contractor shall not permit employment of unfit persons or persons not properly skilled in tasks assigned to them.

### § 3.5 WARRANTY

The Contractor warrants to the Owner and Architect that materials and equipment furnished under the Contract will be of good quality and new unless the Contract Documents require or permit otherwise. The Contractor further warrants that the Work will conform to the requirements of the Contract Documents and will be free from defects, except for those inherent in the quality of the Work the Contract Documents require or permit. Work, materials, or equipment not conforming to these requirements may be considered defective. The Contractor's warranty excludes remedy for damage or defect caused by abuse, alterations to the Work not executed by the Contractor, improper or insufficient maintenance, improper operation, or normal wear and tear and normal usage. If required by the Architect, the Contractor shall furnish satisfactory evidence as to the kind and quality of materials and equipment.

### § 3.6 TAXES

The Contractor shall pay sales, consumer, use and similar taxes for the Work provided by the Contractor that are legally enacted when bids are received or negotiations concluded, whether or not yet effective or merely scheduled to go into effect.

### § 3.7 PERMITS, FEES, NOTICES AND COMPLIANCE WITH LAWS

§ 3.7.1 Unless otherwise provided in the Contract Documents, the Contractor shall secure and pay for the building permit as well as for other permits, fees, licenses, and inspections by government agencies necessary for proper execution and completion of the Work that are customarily secured after execution of the Contract and legally required at the time bids are received or negotiations concluded.

§ 3.7.2 The Contractor shall comply with and give notices required by applicable laws, statutes, ordinances, codes, rules and regulations, and lawful orders of public authorities applicable to performance of the Work.

§ 3.7.3 If the Contractor performs Work knowing it to be contrary to applicable laws, statutes, ordinances, codes, rules and regulations, or lawful orders of public authorities, the Contractor shall assume appropriate responsibility for such Work and shall bear the costs attributable to correction.

§ 3.7.4 **Concealed or Unknown Conditions.** If the Contractor encounters conditions at the site that are (1) subsurface or otherwise concealed physical conditions that differ materially from those indicated in the Contract Documents or (2) unknown physical conditions of an unusual nature, that differ materially from those ordinarily found to exist and generally recognized as inherent in construction activities of the character provided for in the Contract Documents, the Contractor shall promptly provide notice to the Owner and the Architect before conditions are disturbed and in no event later than 21 days after first observance of the conditions. The Architect will promptly investigate such conditions and, if the Architect determines that they differ materially and cause an increase or decrease in the Contractor's cost of, or time required for, performance of any part of the Work, will recommend an equitable adjustment in the Contract Sum or Contract Time, or both. If the Architect determines that the conditions at the site are not materially different from those indicated in the Contract Documents and that no change in the terms of the Contract is justified, the Architect shall promptly notify the Owner and Contractor in writing, stating the reasons. If either party disputes the Architect's determination or recommendation, that party may proceed as provided in Article 15.

§ 3.7.5 If, in the course of the Work, the Contractor encounters human remains or recognizes the existence of burial markers, archaeological sites or wetlands not indicated in the Contract Documents, the Contractor shall immediately suspend any operations that would affect them and shall notify the Owner and Architect. Upon receipt of such notice, the Owner shall promptly take any action necessary to obtain governmental authorization required to resume



the operations. The Contractor shall continue to suspend such operations until otherwise instructed by the Owner but shall continue with all other operations that do not affect those remains or features. Requests for adjustments in the Contract Sum and Contract Time arising from the existence of such remains or features may be made as provided in Article 15.

### § 3.8 ALLOWANCES

§ 3.8.1 The Contractor shall include in the Contract Sum all allowances stated in the Contract Documents. Items covered by allowances shall be supplied for such amounts and by such persons or entities as the Owner may direct, but the Contractor shall not be required to employ persons or entities to whom the Contractor has reasonable objection.

§ 3.8.2 Unless otherwise provided in the Contract Documents,

- .1 Allowances shall cover the cost to the Contractor of materials and equipment delivered at the site and all required taxes, less applicable trade discounts;
- .2 Contractor's costs for unloading and handling at the site, labor, installation costs, overhead, profit and other expenses contemplated for stated allowance amounts shall be included in the Contract Sum but not in the allowances; and
- .3 Whenever costs are more than or less than allowances, the Contract Sum shall be adjusted accordingly by Change Order. The amount of the Change Order shall reflect (1) the difference between actual costs and the allowances under Section 3.8.2.1 and (2) changes in Contractor's costs under Section 3.8.2.2.

§ 3.8.3 Materials and equipment under an allowance shall be selected by the Owner with reasonable promptness.

### § 3.9 SUPERINTENDENT

§ 3.9.1 The Contractor shall employ a competent superintendent and necessary assistants who shall be in attendance at the Project site during performance of the Work. The superintendent shall represent the Contractor, and communications given to the superintendent shall be as binding as if given to the Contractor.

§ 3.9.2 The Contractor, as soon as practicable after award of the Contract, shall furnish in writing to the Owner through the Architect the name and qualifications of a proposed superintendent. The Architect may reply within 14 days to the Contractor in writing stating (1) whether the Owner or the Architect has reasonable objection to the proposed superintendent or (2) that the Architect requires additional time to review. Failure of the Architect to reply within the 14 day period shall constitute notice of no reasonable objection.

§ 3.9.3 The Contractor shall not employ a proposed superintendent to whom the Owner or Architect has made reasonable and timely objection. The Contractor shall not change the superintendent without the Owner's consent, which shall not unreasonably be withheld or delayed.

### § 3.10 CONTRACTOR'S CONSTRUCTION SCHEDULES

§ 3.10.1 The Contractor, promptly after being awarded the Contract, shall prepare and submit for the Owner's and Architect's information a Contractor's construction schedule for the Work. The schedule shall not exceed time limits current under the Contract Documents, shall be revised at appropriate intervals as required by the conditions of the Work and Project, shall be related to the entire Project to the extent required by the Contract Documents, and shall provide for expeditious and practicable execution of the Work.

§ 3.10.2 The Contractor shall prepare a submittal schedule, promptly after being awarded the Contract and thereafter as necessary to maintain a current submittal schedule, and shall submit the schedule(s) for the Architect's approval. The Architect's approval shall not unreasonably be delayed or withheld. The submittal schedule shall (1) be coordinated with the Contractor's construction schedule, and (2) allow the Architect reasonable time to review submittals. If the Contractor fails to submit a submittal schedule, the Contractor shall not be entitled to any increase in Contract Sum or extension of Contract Time based on the time required for review of submittals.

§ 3.10.3 The Contractor shall perform the Work in general accordance with the most recent schedules submitted to the Owner and Architect.

### § 3.11 DOCUMENTS AND SAMPLES AT THE SITE

The Contractor shall maintain at the site for the Owner one copy of the Drawings, Specifications, Addenda, Change Orders and other Modifications, in good order and marked currently to indicate field changes and selections made during construction, and one copy of approved Shop Drawings, Product Data, Samples and similar required submittals. These shall be available to the Architect and shall be delivered to the Architect for submittal to the Owner upon completion of the Work as a record of the Work as constructed.

### § 3.12 SHOP DRAWINGS, PRODUCT DATA AND SAMPLES

§ 3.12.1 Shop Drawings are drawings, diagrams, schedules and other data specially prepared for the Work by the Contractor or a Subcontractor, Sub-subcontractor, manufacturer, supplier or distributor to illustrate some portion of the Work.

§ 3.12.2 Product Data are illustrations, standard schedules, performance charts, instructions, brochures, diagrams and other information furnished by the Contractor to illustrate materials or equipment for some portion of the Work.

§ 3.12.3 Samples are physical examples that illustrate materials, equipment or workmanship and establish standards by which the Work will be judged.

§ 3.12.4 Shop Drawings, Product Data, Samples and similar submittals are not Contract Documents. Their purpose is to demonstrate the way by which the Contractor proposes to conform to the information given and the design concept expressed in the Contract Documents for those portions of the Work for which the Contract Documents require submittals. Review by the Architect is subject to the limitations of Section 4.2.7. Informational submittals upon which the Architect is not expected to take responsive action may be so identified in the Contract Documents. Submittals that are not required by the Contract Documents may be returned by the Architect without action.

§ 3.12.5 The Contractor shall review for compliance with the Contract Documents, approve and submit to the Architect Shop Drawings, Product Data, Samples and similar submittals required by the Contract Documents in accordance with the submittal schedule approved by the Architect or, in the absence of an approved submittal schedule, with reasonable promptness and in such sequence as to cause no delay in the Work or in the activities of the Owner or of separate contractors.

§ 3.12.6 By submitting Shop Drawings, Product Data, Samples and similar submittals, the Contractor represents to the Owner and Architect that the Contractor has (1) reviewed and approved them, (2) determined and verified materials, field measurements and field construction criteria related thereto, or will do so and (3) checked and coordinated the information contained within such submittals with the requirements of the Work and of the Contract Documents.

§ 3.12.7 The Contractor shall perform no portion of the Work for which the Contract Documents require submittal and review of Shop Drawings, Product Data, Samples or similar submittals until the respective submittal has been approved by the Architect.

§ 3.12.8 The Work shall be in accordance with approved submittals except that the Contractor shall not be relieved of responsibility for deviations from requirements of the Contract Documents by the Architect's approval of Shop Drawings, Product Data, Samples or similar submittals unless the Contractor has specifically informed the Architect in writing of such deviation at the time of submittal and (1) the Architect has given written approval to the specific deviation as a minor change in the Work, or (2) a Change Order or Construction Change Directive has been issued authorizing the deviation. The Contractor shall not be relieved of responsibility for errors or omissions in Shop Drawings, Product Data, Samples or similar submittals by the Architect's approval thereof.

§ 3.12.9 The Contractor shall direct specific attention, in writing or on resubmitted Shop Drawings, Product Data, Samples or similar submittals, to revisions other than those requested by the Architect on previous submittals. In the absence of such written notice, the Architect's approval of a resubmission shall not apply to such revisions.

§ 3.12.10 The Contractor shall not be required to provide professional services that constitute the practice of architecture or engineering unless such services are specifically required by the Contract Documents for a portion of the Work or unless the Contractor needs to provide such services in order to carry out the Contractor's responsibilities for construction means, methods, techniques, sequences and procedures. The Contractor shall not be

Init.

required to provide professional services in violation of applicable law. If professional design services or certifications by a design professional related to systems, materials or equipment are specifically required of the Contractor by the Contract Documents, the Owner and the Architect will specify all performance and design criteria that such services must satisfy. The Contractor shall cause such services or certifications to be provided by a properly licensed design professional, whose signature and seal shall appear on all drawings, calculations, specifications, certifications, Shop Drawings and other submittals prepared by such professional. Shop Drawings and other submittals related to the Work designed or certified by such professional, if prepared by others, shall bear such professional's written approval when submitted to the Architect. The Owner and the Architect shall be entitled to rely upon the adequacy, accuracy and completeness of the services, certifications and approvals performed or provided by such design professionals, provided the Owner and Architect have specified to the Contractor all performance and design criteria that such services must satisfy. Pursuant to this Section 3.12.10, the Architect will review, approve or take other appropriate action on submittals only for the limited purpose of checking for conformance with information given and the design concept expressed in the Contract Documents. The Contractor shall not be responsible for the adequacy of the performance and design criteria specified in the Contract Documents.

### § 3.13 USE OF SITE

The Contractor shall confine operations at the site to areas permitted by applicable laws, statutes, ordinances, codes, rules and regulations, and lawful orders of public authorities and the Contract Documents and shall not unreasonably encumber the site with materials or equipment.

### § 3.14 CUTTING AND PATCHING

§ 3.14.1 The Contractor shall be responsible for cutting, fitting or patching required to complete the Work or to make its parts fit together properly. All areas requiring cutting, fitting and patching shall be restored to the condition existing prior to the cutting, fitting and patching, unless otherwise required by the Contract Documents.

§ 3.14.2 The Contractor shall not damage or endanger a portion of the Work or fully or partially completed construction of the Owner or separate contractors by cutting, patching or otherwise altering such construction, or by excavation. The Contractor shall not cut or otherwise alter such construction by the Owner or a separate contractor except with written consent of the Owner and of such separate contractor; such consent shall not be unreasonably withheld. The Contractor shall not unreasonably withhold from the Owner or a separate contractor the Contractor's consent to cutting or otherwise altering the Work.

### § 3.15 CLEANING UP

§ 3.15.1 The Contractor shall keep the premises and surrounding area free from accumulation of waste materials or rubbish caused by operations under the Contract. At completion of the Work, the Contractor shall remove waste materials, rubbish, the Contractor's tools, construction equipment, machinery and surplus materials from and about the Project.

§ 3.15.2 If the Contractor fails to clean up as provided in the Contract Documents, the Owner may do so and Owner shall be entitled to reimbursement from the Contractor.

### § 3.16 ACCESS TO WORK

The Contractor shall provide the Owner and Architect access to the Work in preparation and progress wherever located.

### § 3.17 ROYALTIES, PATENTS AND COPYRIGHTS

The Contractor shall pay all royalties and license fees. The Contractor shall defend suits or claims for infringement of copyrights and patent rights and shall hold the Owner and Architect harmless from loss on account thereof, but shall not be responsible for such defense or loss when a particular design, process or product of a particular manufacturer or manufacturers is required by the Contract Documents, or where the copyright violations are contained in Drawings, Specifications or other documents prepared by the Owner or Architect. However, if the Contractor has reason to believe that the required design, process or product is an infringement of a copyright or a patent, the Contractor shall be responsible for such loss unless such information is promptly furnished to the Architect.



### § 3.18 INDEMNIFICATION

§ 3.18.1 To the fullest extent permitted by law the Contractor shall indemnify and hold harmless the Owner, Architect, Architect's consultants, and agents and employees of any of them from and against claims, damages, losses and expenses, including but not limited to attorneys' fees, arising out of or resulting from performance of the Work, provided that such claim, damage, loss or expense is attributable to bodily injury, sickness, disease or death, or to injury to or destruction of tangible property (other than the Work itself), but only to the extent caused by the negligent acts or omissions of the Contractor, a Subcontractor, anyone directly or indirectly employed by them or anyone for whose acts they may be liable, regardless of whether or not such claim, damage, loss or expense is caused in part by a party indemnified hereunder. Such obligation shall not be construed to negate, abridge, or reduce other rights or obligations of indemnity that would otherwise exist as to a party or person described in this Section 3.18.

§ 3.18.2 In claims against any person or entity indemnified under this Section 3.18 by an employee of the Contractor, a Subcontractor, anyone directly or indirectly employed by them or anyone for whose acts they may be liable, the indemnification obligation under Section 3.18.1 shall not be limited by a limitation on amount or type of damages, compensation or benefits payable by or for the Contractor or a Subcontractor under workers' compensation acts, disability benefit acts or other employee benefit acts.

## ARTICLE 4 ARCHITECT

### § 4.1 GENERAL

§ 4.1.1 The Owner shall retain an architect lawfully licensed to practice architecture or an entity lawfully practicing architecture in the jurisdiction where the Project is located. That person or entity is identified as the Architect in the Agreement and is referred to throughout the Contract Documents as if singular in number.

§ 4.1.2 Duties, responsibilities and limitations of authority of the Architect as set forth in the Contract Documents shall not be restricted, modified or extended without written consent of the Owner, Contractor and Architect. Consent shall not be unreasonably withheld.

§ 4.1.3 If the employment of the Architect is terminated, the Owner shall employ a successor architect as to whom the Contractor has no reasonable objection and whose status under the Contract Documents shall be that of the Architect.

### § 4.2 ADMINISTRATION OF THE CONTRACT

§ 4.2.1 The Architect will provide administration of the Contract as described in the Contract Documents and will be an Owner's representative during construction until the date the Architect issues the final Certificate for Payment. The Architect will have authority to act on behalf of the Owner only to the extent provided in the Contract Documents.

§ 4.2.2 The Architect will visit the site at intervals appropriate to the stage of construction, or as otherwise agreed with the Owner, to become generally familiar with the progress and quality of the portion of the Work completed, and to determine in general if the Work observed is being performed in a manner indicating that the Work, when fully completed, will be in accordance with the Contract Documents. However, the Architect will not be required to make exhaustive or continuous on-site inspections to check the quality or quantity of the Work. The Architect will not have control over, charge of, or responsibility for, the construction means, methods, techniques, sequences or procedures, or for the safety precautions and programs in connection with the Work, since these are solely the Contractor's rights and responsibilities under the Contract Documents, except as provided in Section 3.3.1.

§ 4.2.3 On the basis of the site visits, the Architect will keep the Owner reasonably informed about the progress and quality of the portion of the Work completed, and report to the Owner (1) known deviations from the Contract Documents and from the most recent construction schedule submitted by the Contractor, and (2) defects and deficiencies observed in the Work. The Architect will not be responsible for the Contractor's failure to perform the Work in accordance with the requirements of the Contract Documents. The Architect will not have control over or charge of and will not be responsible for acts or omissions of the Contractor, Subcontractors, or their agents or employees, or any other persons or entities performing portions of the Work.

#### § 4.2.4 COMMUNICATIONS FACILITATING CONTRACT ADMINISTRATION

Except as otherwise provided in the Contract Documents or when direct communications have been specially authorized, the Owner and Contractor shall endeavor to communicate with each other through the Architect about matters arising out of or relating to the Contract. Communications by and with the Architect's consultants shall be through the Architect. Communications by and with Subcontractors and material suppliers shall be through the Contractor. Communications by and with separate contractors shall be through the Owner.

§ 4.2.5 Based on the Architect's evaluations of the Contractor's Applications for Payment, the Architect will review and certify the amounts due the Contractor and will issue Certificates for Payment in such amounts.

§ 4.2.6 The Architect has authority to reject Work that does not conform to the Contract Documents. Whenever the Architect considers it necessary or advisable, the Architect will have authority to require inspection or testing of the Work in accordance with Sections 13.5.2 and 13.5.3, whether or not such Work is fabricated, installed or completed. However, neither this authority of the Architect nor a decision made in good faith either to exercise or not to exercise such authority shall give rise to a duty or responsibility of the Architect to the Contractor, Subcontractors, material and equipment suppliers, their agents or employees, or other persons or entities performing portions of the Work.

§ 4.2.7 The Architect will review and approve, or take other appropriate action upon, the Contractor's submittals such as Shop Drawings, Product Data and Samples, but only for the limited purpose of checking for conformance with information given and the design concept expressed in the Contract Documents. The Architect's action will be taken in accordance with the submittal schedule approved by the Architect or, in the absence of an approved submittal schedule, with reasonable promptness while allowing sufficient time in the Architect's professional judgment to permit adequate review. Review of such submittals is not conducted for the purpose of determining the accuracy and completeness of other details such as dimensions and quantities, or for substantiating instructions for installation or performance of equipment or systems, all of which remain the responsibility of the Contractor as required by the Contract Documents. The Architect's review of the Contractor's submittals shall not relieve the Contractor of the obligations under Sections 3.3, 3.5 and 3.12. The Architect's review shall not constitute approval of safety precautions or, unless otherwise specifically stated by the Architect, of any construction means, methods, techniques, sequences or procedures. The Architect's approval of a specific item shall not indicate approval of an assembly of which the item is a component.

§ 4.2.8 The Architect will prepare Change Orders and Construction Change Directives, and may authorize minor changes in the Work as provided in Section 7.4. The Architect will investigate and make determinations and recommendations regarding concealed and unknown conditions as provided in Section 3.7.4.

§ 4.2.9 The Architect will conduct inspections to determine the date or dates of Substantial Completion and the date of final completion; issue Certificates of Substantial Completion pursuant to Section 9.8; receive and forward to the Owner, for the Owner's review and records, written warranties and related documents required by the Contract and assembled by the Contractor pursuant to Section 9.10; and issue a final Certificate for Payment pursuant to Section 9.10.

§ 4.2.10 If the Owner and Architect agree, the Architect will provide one or more project representatives to assist in carrying out the Architect's responsibilities at the site. The duties, responsibilities and limitations of authority of such project representatives shall be as set forth in an exhibit to be incorporated in the Contract Documents.

§ 4.2.11 The Architect will interpret and decide matters concerning performance under, and requirements of, the Contract Documents on written request of either the Owner or Contractor. The Architect's response to such requests will be made in writing within any time limits agreed upon or otherwise with reasonable promptness.

§ 4.2.12 Interpretations and decisions of the Architect will be consistent with the intent of, and reasonably inferable from, the Contract Documents and will be in writing or in the form of drawings. When making such interpretations and decisions, the Architect will endeavor to secure faithful performance by both Owner and Contractor, will not show partiality to either and will not be liable for results of interpretations or decisions rendered in good faith.

§ 4.2.13 The Architect's decisions on matters relating to aesthetic effect will be final if consistent with the intent expressed in the Contract Documents.

Init.



§ 4.2.14 The Architect will review and respond to requests for information about the Contract Documents. The Architect's response to such requests will be made in writing within any time limits agreed upon or otherwise with reasonable promptness. If appropriate, the Architect will prepare and issue supplemental Drawings and Specifications in response to the requests for information.

## ARTICLE 5 SUBCONTRACTORS

### § 5.1 DEFINITIONS

§ 5.1.1 A Subcontractor is a person or entity who has a direct contract with the Contractor to perform a portion of the Work at the site. The term "Subcontractor" is referred to throughout the Contract Documents as if singular in number and means a Subcontractor or an authorized representative of the Subcontractor. The term "Subcontractor" does not include a separate contractor or subcontractors of a separate contractor.

§ 5.1.2 A Sub-subcontractor is a person or entity who has a direct or indirect contract with a Subcontractor to perform a portion of the Work at the site. The term "Sub-subcontractor" is referred to throughout the Contract Documents as if singular in number and means a Sub-subcontractor or an authorized representative of the Sub-subcontractor.

### § 5.2 AWARD OF SUBCONTRACTS AND OTHER CONTRACTS FOR PORTIONS OF THE WORK

§ 5.2.1 Unless otherwise stated in the Contract Documents or the bidding requirements, the Contractor, as soon as practicable after award of the Contract, shall furnish in writing to the Owner through the Architect the names of persons or entities (including those who are to furnish materials or equipment fabricated to a special design) proposed for each principal portion of the Work. The Architect may reply within 14 days to the Contractor in writing stating (1) whether the Owner or the Architect has reasonable objection to any such proposed person or entity or (2) that the Architect requires additional time for review. Failure of the Owner or Architect to reply within the 14-day period shall constitute notice of no reasonable objection.

§ 5.2.2 The Contractor shall not contract with a proposed person or entity to whom the Owner or Architect has made reasonable and timely objection. The Contractor shall not be required to contract with anyone to whom the Contractor has made reasonable objection.

§ 5.2.3 If the Owner or Architect has reasonable objection to a person or entity proposed by the Contractor, the Contractor shall propose another to whom the Owner or Architect has no reasonable objection. If the proposed but rejected Subcontractor was reasonably capable of performing the Work, the Contract Sum and Contract Time shall be increased or decreased by the difference, if any, occasioned by such change, and an appropriate Change Order shall be issued before commencement of the substitute Subcontractor's Work. However, no increase in the Contract Sum or Contract Time shall be allowed for such change unless the Contractor has acted promptly and responsively in submitting names as required.

§ 5.2.4 The Contractor shall not substitute a Subcontractor, person or entity previously selected if the Owner or Architect makes reasonable objection to such substitution.

### § 5.3 SUBCONTRACTUAL RELATIONS

By appropriate agreement, written where legally required for validity, the Contractor shall require each Subcontractor, to the extent of the Work to be performed by the Subcontractor, to be bound to the Contractor by terms of the Contract Documents, and to assume toward the Contractor all the obligations and responsibilities, including the responsibility for safety of the Subcontractor's Work, which the Contractor, by these Documents, assumes toward the Owner and Architect. Each subcontract agreement shall preserve and protect the rights of the Owner and Architect under the Contract Documents with respect to the Work to be performed by the Subcontractor so that subcontracting thereof will not prejudice such rights, and shall allow to the Subcontractor, unless specifically provided otherwise in the subcontract agreement, the benefit of all rights, remedies and redress against the Contractor that the Contractor, by the Contract Documents, has against the Owner. Where appropriate, the Contractor shall require each Subcontractor to enter into similar agreements with Sub-subcontractors. The Contractor shall make available to each proposed Subcontractor, prior to the execution of the subcontract agreement, copies of the Contract Documents to which the Subcontractor will be bound, and, upon written request of the Subcontractor, identify to the Subcontractor terms and conditions of the proposed subcontract agreement that may

Init.

be at variance with the Contract Documents. Subcontractors will similarly make copies of applicable portions of such documents available to their respective proposed Sub-subcontractors.

#### § 5.4 CONTINGENT ASSIGNMENT OF SUBCONTRACTS

§ 5.4.1 Each subcontract agreement for a portion of the Work is assigned by the Contractor to the Owner, provided that

- .1 assignment is effective only after termination of the Contract by the Owner for cause pursuant to Section 14.2 and only for those subcontract agreements that the Owner accepts by notifying the Subcontractor and Contractor in writing; and
- .2 assignment is subject to the prior rights of the surety, if any, obligated under bond relating to the Contract.

When the Owner accepts the assignment of a subcontract agreement, the Owner assumes the Contractor's rights and obligations under the subcontract.

§ 5.4.2 Upon such assignment, if the Work has been suspended for more than 30 days, the Subcontractor's compensation shall be equitably adjusted for increases in cost resulting from the suspension.

§ 5.4.3 Upon such assignment to the Owner under this Section 5.4, the Owner may further assign the subcontract to a successor contractor or other entity. If the Owner assigns the subcontract to a successor contractor or other entity, the Owner shall nevertheless remain legally responsible for all of the successor contractor's obligations under the subcontract.

### ARTICLE 6 CONSTRUCTION BY OWNER OR BY SEPARATE CONTRACTORS

#### § 6.1 OWNER'S RIGHT TO PERFORM CONSTRUCTION AND TO AWARD SEPARATE CONTRACTS

§ 6.1.1 The Owner reserves the right to perform construction or operations related to the Project with the Owner's own forces, and to award separate contracts in connection with other portions of the Project or other construction or operations on the site under Conditions of the Contract identical or substantially similar to these including those portions related to insurance and waiver of subrogation. If the Contractor claims that delay or additional cost is involved because of such action by the Owner, the Contractor shall make such Claim as provided in Article 15.

§ 6.1.2 When separate contracts are awarded for different portions of the Project or other construction or operations on the site, the term "Contractor" in the Contract Documents in each case shall mean the Contractor who executes each separate Owner-Contractor Agreement.

§ 6.1.3 The Owner shall provide for coordination of the activities of the Owner's own forces and of each separate contractor with the Work of the Contractor, who shall cooperate with them. The Contractor shall participate with other separate contractors and the Owner in reviewing their construction schedules. The Contractor shall make any revisions to the construction schedule deemed necessary after a joint review and mutual agreement. The construction schedules shall then constitute the schedules to be used by the Contractor, separate contractors and the Owner until subsequently revised.

§ 6.1.4 Unless otherwise provided in the Contract Documents, when the Owner performs construction or operations related to the Project with the Owner's own forces, the Owner shall be deemed to be subject to the same obligations and to have the same rights that apply to the Contractor under the Conditions of the Contract, including, without excluding others, those stated in Article 3, this Article 6 and Articles 10, 11 and 12.

#### § 6.2 MUTUAL RESPONSIBILITY

§ 6.2.1 The Contractor shall afford the Owner and separate contractors reasonable opportunity for introduction and storage of their materials and equipment and performance of their activities, and shall connect and coordinate the Contractor's construction and operations with theirs as required by the Contract Documents.

§ 6.2.2 If part of the Contractor's Work depends for proper execution or results upon construction or operations by the Owner or a separate contractor, the Contractor shall, prior to proceeding with that portion of the Work, promptly report to the Architect apparent discrepancies or defects in such other construction that would render it unsuitable for such proper execution and results. Failure of the Contractor so to report shall constitute an acknowledgment that

the Owner's or separate contractor's completed or partially completed construction is fit and proper to receive the Contractor's Work, except as to defects not then reasonably discoverable.

§ 6.2.3 The Contractor shall reimburse the Owner for costs the Owner incurs that are payable to a separate contractor because of the Contractor's delays, improperly timed activities or defective construction. The Owner shall be responsible to the Contractor for costs the Contractor incurs because of a separate contractor's delays, improperly timed activities, damage to the Work or defective construction.

§ 6.2.4 The Contractor shall promptly remedy damage the Contractor wrongfully causes to completed or partially completed construction or to property of the Owner or separate contractors as provided in Section 10.2.5.

§ 6.2.5 The Owner and each separate contractor shall have the same responsibilities for cutting and patching as are described for the Contractor in Section 3.14.

### § 6.3 OWNER'S RIGHT TO CLEAN UP

If a dispute arises among the Contractor, separate contractors and the Owner as to the responsibility under their respective contracts for maintaining the premises and surrounding area free from waste materials and rubbish, the Owner may clean up and the Architect will allocate the cost among those responsible.

## ARTICLE 7 CHANGES IN THE WORK

### § 7.1 GENERAL

§ 7.1.1 Changes in the Work may be accomplished after execution of the Contract, and without invalidating the Contract, by Change Order, Construction Change Directive or order for a minor change in the Work, subject to the limitations stated in this Article 7 and elsewhere in the Contract Documents.

§ 7.1.2 A Change Order shall be based upon agreement among the Owner, Contractor and Architect; a Construction Change Directive requires agreement by the Owner and Architect and may or may not be agreed to by the Contractor; an order for a minor change in the Work may be issued by the Architect alone.

§ 7.1.3 Changes in the Work shall be performed under applicable provisions of the Contract Documents, and the Contractor shall proceed promptly, unless otherwise provided in the Change Order, Construction Change Directive or order for a minor change in the Work.

### § 7.2 CHANGE ORDERS

§ 7.2.1 A Change Order is a written instrument prepared by the Architect and signed by the Owner, Contractor and Architect stating their agreement upon all of the following:

- .1 The change in the Work;
- .2 The amount of the adjustment, if any, in the Contract Sum; and
- .3 The extent of the adjustment, if any, in the Contract Time.

### § 7.3 CONSTRUCTION CHANGE DIRECTIVES

§ 7.3.1 A Construction Change Directive is a written order prepared by the Architect and signed by the Owner and Architect, directing a change in the Work prior to agreement on adjustment, if any, in the Contract Sum or Contract Time, or both. The Owner may by Construction Change Directive, without invalidating the Contract, order changes in the Work within the general scope of the Contract consisting of additions, deletions or other revisions, the Contract Sum and Contract Time being adjusted accordingly.

§ 7.3.2 A Construction Change Directive shall be used in the absence of total agreement on the terms of a Change Order.

§ 7.3.3 If the Construction Change Directive provides for an adjustment to the Contract Sum, the adjustment shall be based on one of the following methods:

- .1 Mutual acceptance of a lump sum properly itemized and supported by sufficient substantiating data to permit evaluation;
- .2 Unit prices stated in the Contract Documents or subsequently agreed upon;
- .3 Cost to be determined in a manner agreed upon by the parties and a mutually acceptable fixed or percentage fee; or

Init.

.4 As provided in Section 7.3.7.

§ 7.3.4 If unit prices are stated in the Contract Documents or subsequently agreed upon, and if quantities originally contemplated are materially changed in a proposed Change Order or Construction Change Directive so that application of such unit prices to quantities of Work proposed will cause substantial inequity to the Owner or Contractor, the applicable unit prices shall be equitably adjusted.

§ 7.3.5 Upon receipt of a Construction Change Directive, the Contractor shall promptly proceed with the change in the Work involved and advise the Architect of the Contractor's agreement or disagreement with the method, if any, provided in the Construction Change Directive for determining the proposed adjustment in the Contract Sum or Contract Time.

§ 7.3.6 A Construction Change Directive signed by the Contractor indicates the Contractor's agreement therewith, including adjustment in Contract Sum and Contract Time or the method for determining them. Such agreement shall be effective immediately and shall be recorded as a Change Order.

§ 7.3.7 If the Contractor does not respond promptly or disagrees with the method for adjustment in the Contract Sum, the Architect shall determine the method and the adjustment on the basis of reasonable expenditures and savings of those performing the Work attributable to the change, including, in case of an increase in the Contract Sum, an amount for overhead and profit as set forth in the Agreement, or if no such amount is set forth in the Agreement, a reasonable amount. In such case, and also under Section 7.3.3.3, the Contractor shall keep and present, in such form as the Architect may prescribe, an itemized accounting together with appropriate supporting data. Unless otherwise provided in the Contract Documents, costs for the purposes of this Section 7.3.7 shall be limited to the following:

- .1 Costs of labor, including social security, old age and unemployment insurance, fringe benefits required by agreement or custom, and workers' compensation insurance;
- .2 Costs of materials, supplies and equipment, including cost of transportation, whether incorporated or consumed;
- .3 Rental costs of machinery and equipment, exclusive of hand tools, whether rented from the Contractor or others;
- .4 Costs of premiums for all bonds and insurance, permit fees, and sales, use or similar taxes related to the Work; and
- .5 Additional costs of supervision and field office personnel directly attributable to the change.

§ 7.3.8 The amount of credit to be allowed by the Contractor to the Owner for a deletion or change that results in a net decrease in the Contract Sum shall be actual net cost as confirmed by the Architect. When both additions and credits covering related Work or substitutions are involved in a change, the allowance for overhead and profit shall be figured on the basis of net increase, if any, with respect to that change.

§ 7.3.9 Pending final determination of the total cost of a Construction Change Directive to the Owner, the Contractor may request payment for Work completed under the Construction Change Directive in Applications for Payment. The Architect will make an interim determination for purposes of monthly certification for payment for those costs and certify for payment the amount that the Architect determines, in the Architect's professional judgment, to be reasonably justified. The Architect's interim determination of cost shall adjust the Contract Sum on the same basis as a Change Order, subject to the right of either party to disagree and assert a Claim in accordance with Article 15.

§ 7.3.10 When the Owner and Contractor agree with a determination made by the Architect concerning the adjustments in the Contract Sum and Contract Time, or otherwise reach agreement upon the adjustments, such agreement shall be effective immediately and the Architect will prepare a Change Order. Change Orders may be issued for all or any part of a Construction Change Directive.

#### § 7.4 MINOR CHANGES IN THE WORK

The Architect has authority to order minor changes in the Work not involving adjustment in the Contract Sum or extension of the Contract Time and not inconsistent with the intent of the Contract Documents. Such changes will be effected by written order signed by the Architect and shall be binding on the Owner and Contractor.



**ARTICLE 8 TIME****§ 8.1 DEFINITIONS**

§ 8.1.1 Unless otherwise provided, Contract Time is the period of time, including authorized adjustments, allotted in the Contract Documents for Substantial Completion of the Work.

§ 8.1.2 The date of commencement of the Work is the date established in the Agreement.

§ 8.1.3 The date of Substantial Completion is the date certified by the Architect in accordance with Section 9.8.

§ 8.1.4 The term "day" as used in the Contract Documents shall mean calendar day unless otherwise specifically defined.

**§ 8.2 PROGRESS AND COMPLETION**

§ 8.2.1 Time limits stated in the Contract Documents are of the essence of the Contract. By executing the Agreement the Contractor confirms that the Contract Time is a reasonable period for performing the Work.

§ 8.2.2 The Contractor shall not knowingly, except by agreement or instruction of the Owner in writing, prematurely commence operations on the site or elsewhere prior to the effective date of insurance required by Article 11 to be furnished by the Contractor and Owner. The date of commencement of the Work shall not be changed by the effective date of such insurance.

§ 8.2.3 The Contractor shall proceed expeditiously with adequate forces and shall achieve Substantial Completion within the Contract Time.

**§ 8.3 DELAYS AND EXTENSIONS OF TIME**

§ 8.3.1 If the Contractor is delayed at any time in the commencement or progress of the Work by an act or neglect of the Owner or Architect, or of an employee of either, or of a separate contractor employed by the Owner; or by changes ordered in the Work; or by labor disputes, fire, unusual delay in deliveries, unavoidable casualties or other causes beyond the Contractor's control; or by delay authorized by the Owner pending mediation and arbitration; or by other causes that the Architect determines may justify delay, then the Contract Time shall be extended by Change Order for such reasonable time as the Architect may determine.

§ 8.3.2 Claims relating to time shall be made in accordance with applicable provisions of Article 15.

§ 8.3.3 This Section 8.3 does not preclude recovery of damages for delay by either party under other provisions of the Contract Documents.

**ARTICLE 9 PAYMENTS AND COMPLETION****§ 9.1 CONTRACT SUM**

The Contract Sum is stated in the Agreement and, including authorized adjustments, is the total amount payable by the Owner to the Contractor for performance of the Work under the Contract Documents.

**§ 9.2 SCHEDULE OF VALUES**

Where the Contract is based on a stipulated sum or Guaranteed Maximum Price, the Contractor shall submit to the Architect, before the first Application for Payment, a schedule of values allocating the entire Contract Sum to the various portions of the Work and prepared in such form and supported by such data to substantiate its accuracy as the Architect may require. This schedule, unless objected to by the Architect, shall be used as a basis for reviewing the Contractor's Applications for Payment.

**§ 9.3 APPLICATIONS FOR PAYMENT**

§ 9.3.1 At least ten days before the date established for each progress payment, the Contractor shall submit to the Architect an itemized Application for Payment prepared in accordance with the schedule of values, if required under Section 9.2, for completed portions of the Work. Such application shall be notarized, if required, and supported by such data substantiating the Contractor's right to payment as the Owner or Architect may require, such as copies of requisitions from Subcontractors and material suppliers, and shall reflect retainage if provided for in the Contract Documents.

Init.

§ 9.3.1.1 As provided in Section 7.3.9, such applications may include requests for payment on account of changes in the Work that have been properly authorized by Construction Change Directives, or by interim determinations of the Architect, but not yet included in Change Orders.

§ 9.3.1.2 Applications for Payment shall not include requests for payment for portions of the Work for which the Contractor does not intend to pay a Subcontractor or material supplier, unless such Work has been performed by others whom the Contractor intends to pay.

§ 9.3.2 Unless otherwise provided in the Contract Documents, payments shall be made on account of materials and equipment delivered and suitably stored at the site for subsequent incorporation in the Work. If approved in advance by the Owner, payment may similarly be made for materials and equipment suitably stored off the site at a location agreed upon in writing. Payment for materials and equipment stored on or off the site shall be conditioned upon compliance by the Contractor with procedures satisfactory to the Owner to establish the Owner's title to such materials and equipment or otherwise protect the Owner's interest, and shall include the costs of applicable insurance, storage and transportation to the site for such materials and equipment stored off the site.

§ 9.3.3 The Contractor warrants that title to all Work covered by an Application for Payment will pass to the Owner no later than the time of payment. The Contractor further warrants that upon submittal of an Application for Payment all Work for which Certificates for Payment have been previously issued and payments received from the Owner shall, to the best of the Contractor's knowledge, information and belief, be free and clear of liens, claims, security interests or encumbrances in favor of the Contractor, Subcontractors, material suppliers, or other persons or entities making a claim by reason of having provided labor, materials and equipment relating to the Work.

#### § 9.4 CERTIFICATES FOR PAYMENT

§ 9.4.1 The Architect will, within seven days after receipt of the Contractor's Application for Payment, either issue to the Owner a Certificate for Payment, with a copy to the Contractor, for such amount as the Architect determines is properly due, or notify the Contractor and Owner in writing of the Architect's reasons for withholding certification in whole or in part as provided in Section 9.5.1.

§ 9.4.2 The issuance of a Certificate for Payment will constitute a representation by the Architect to the Owner, based on the Architect's evaluation of the Work and the data comprising the Application for Payment, that, to the best of the Architect's knowledge, information and belief, the Work has progressed to the point indicated and that the quality of the Work is in accordance with the Contract Documents. The foregoing representations are subject to an evaluation of the Work for conformance with the Contract Documents upon Substantial Completion, to results of subsequent tests and inspections, to correction of minor deviations from the Contract Documents prior to completion and to specific qualifications expressed by the Architect. The issuance of a Certificate for Payment will further constitute a representation that the Contractor is entitled to payment in the amount certified. However, the issuance of a Certificate for Payment will not be a representation that the Architect has (1) made exhaustive or continuous on-site inspections to check the quality or quantity of the Work, (2) reviewed construction means, methods, techniques, sequences or procedures, (3) reviewed copies of requisitions received from Subcontractors and material suppliers and other data requested by the Owner to substantiate the Contractor's right to payment, or (4) made examination to ascertain how or for what purpose the Contractor has used money previously paid on account of the Contract Sum.

#### § 9.5 DECISIONS TO WITHHOLD CERTIFICATION

§ 9.5.1 The Architect may withhold a Certificate for Payment in whole or in part, to the extent reasonably necessary to protect the Owner, if in the Architect's opinion the representations to the Owner required by Section 9.4.2 cannot be made. If the Architect is unable to certify payment in the amount of the Application, the Architect will notify the Contractor and Owner as provided in Section 9.4.1. If the Contractor and Architect cannot agree on a revised amount, the Architect will promptly issue a Certificate for Payment for the amount for which the Architect is able to make such representations to the Owner. The Architect may also withhold a Certificate for Payment or, because of subsequently discovered evidence, may nullify the whole or a part of a Certificate for Payment previously issued, to such extent as may be necessary in the Architect's opinion to protect the Owner from loss for which the Contractor is responsible, including loss resulting from acts and omissions described in Section 3.3.2, because of

- .1 defective Work not remedied;
- .2 third party claims filed or reasonable evidence indicating probable filing of such claims unless security acceptable to the Owner is provided by the Contractor;

Init.

- .3 failure of the Contractor to make payments properly to Subcontractors or for labor, materials or equipment;
- .4 reasonable evidence that the Work cannot be completed for the unpaid balance of the Contract Sum;
- .5 damage to the Owner or a separate contractor;
- .6 reasonable evidence that the Work will not be completed within the Contract Time, and that the unpaid balance would not be adequate to cover actual or liquidated damages for the anticipated delay; or
- .7 repeated failure to carry out the Work in accordance with the Contract Documents.

§ 9.5.2 When the above reasons for withholding certification are removed, certification will be made for amounts previously withheld.

§ 9.5.3 If the Architect withholds certification for payment under Section 9.5.1.3, the Owner may, at its sole option, issue joint checks to the Contractor and to any Subcontractor or material or equipment suppliers to whom the Contractor failed to make payment for Work properly performed or material or equipment suitably delivered. If the Owner makes payments by joint check, the Owner shall notify the Architect and the Architect will reflect such payment on the next Certificate for Payment.

#### § 9.6 PROGRESS PAYMENTS

§ 9.6.1 After the Architect has issued a Certificate for Payment, the Owner shall make payment in the manner and within the time provided in the Contract Documents, and shall so notify the Architect.

§ 9.6.2 The Contractor shall pay each Subcontractor no later than seven days after receipt of payment from the Owner the amount to which the Subcontractor is entitled, reflecting percentages actually retained from payments to the Contractor on account of the Subcontractor's portion of the Work. The Contractor shall, by appropriate agreement with each Subcontractor, require each Subcontractor to make payments to Sub-subcontractors in a similar manner.

§ 9.6.3 The Architect will, on request, furnish to a Subcontractor, if practicable, information regarding percentages of completion or amounts applied for by the Contractor and action taken thereon by the Architect and Owner on account of portions of the Work done by such Subcontractor.

§ 9.6.4 The Owner has the right to request written evidence from the Contractor that the Contractor has properly paid Subcontractors and material and equipment suppliers amounts paid by the Owner to the Contractor for subcontracted Work. If the Contractor fails to furnish such evidence within seven days, the Owner shall have the right to contact Subcontractors to ascertain whether they have been properly paid. Neither the Owner nor Architect shall have an obligation to pay or to see to the payment of money to a Subcontractor, except as may otherwise be required by law.

§ 9.6.5 Contractor payments to material and equipment suppliers shall be treated in a manner similar to that provided in Sections 9.6.2, 9.6.3 and 9.6.4.

§ 9.6.6 A Certificate for Payment, a progress payment, or partial or entire use or occupancy of the Project by the Owner shall not constitute acceptance of Work not in accordance with the Contract Documents.

§ 9.6.7 Unless the Contractor provides the Owner with a payment bond in the full penal sum of the Contract Sum, payments received by the Contractor for Work properly performed by Subcontractors and suppliers shall be held by the Contractor for those Subcontractors or suppliers who performed Work or furnished materials, or both, under contract with the Contractor for which payment was made by the Owner. Nothing contained herein shall require money to be placed in a separate account and not commingled with money of the Contractor, shall create any fiduciary liability or tort liability on the part of the Contractor for breach of trust or shall entitle any person or entity to an award of punitive damages against the Contractor for breach of the requirements of this provision.

#### § 9.7 FAILURE OF PAYMENT

If the Architect does not issue a Certificate for Payment, through no fault of the Contractor, within seven days after receipt of the Contractor's Application for Payment, or if the Owner does not pay the Contractor within seven days after the date established in the Contract Documents the amount certified by the Architect or awarded by binding

Init.

dispute resolution, then the Contractor may, upon seven additional days' written notice to the Owner and Architect, stop the Work until payment of the amount owing has been received. The Contract Time shall be extended appropriately and the Contract Sum shall be increased by the amount of the Contractor's reasonable costs of shut-down, delay and start-up, plus interest as provided for in the Contract Documents.

### § 9.8 SUBSTANTIAL COMPLETION

§ 9.8.1 Substantial Completion is the stage in the progress of the Work when the Work or designated portion thereof is sufficiently complete in accordance with the Contract Documents so that the Owner can occupy or utilize the Work for its intended use.

§ 9.8.2 When the Contractor considers that the Work, or a portion thereof which the Owner agrees to accept separately, is substantially complete, the Contractor shall prepare and submit to the Architect a comprehensive list of items to be completed or corrected prior to final payment. Failure to include an item on such list does not alter the responsibility of the Contractor to complete all Work in accordance with the Contract Documents.

§ 9.8.3 Upon receipt of the Contractor's list, the Architect will make an inspection to determine whether the Work or designated portion thereof is substantially complete. If the Architect's inspection discloses any item, whether or not included on the Contractor's list, which is not sufficiently complete in accordance with the Contract Documents so that the Owner can occupy or utilize the Work or designated portion thereof for its intended use, the Contractor shall, before issuance of the Certificate of Substantial Completion, complete or correct such item upon notification by the Architect. In such case, the Contractor shall then submit a request for another inspection by the Architect to determine Substantial Completion.

§ 9.8.4 When the Work or designated portion thereof is substantially complete, the Architect will prepare a Certificate of Substantial Completion that shall establish the date of Substantial Completion, shall establish responsibilities of the Owner and Contractor for security, maintenance, heat, utilities, damage to the Work and insurance, and shall fix the time within which the Contractor shall finish all items on the list accompanying the Certificate. Warranties required by the Contract Documents shall commence on the date of Substantial Completion of the Work or designated portion thereof unless otherwise provided in the Certificate of Substantial Completion.

§ 9.8.5 The Certificate of Substantial Completion shall be submitted to the Owner and Contractor for their written acceptance of responsibilities assigned to them in such Certificate. Upon such acceptance and consent of surety, if any, the Owner shall make payment of retainage applying to such Work or designated portion thereof. Such payment shall be adjusted for Work that is incomplete or not in accordance with the requirements of the Contract Documents.

### § 9.9 PARTIAL OCCUPANCY OR USE

§ 9.9.1 The Owner may occupy or use any completed or partially completed portion of the Work at any stage when such portion is designated by separate agreement with the Contractor, provided such occupancy or use is consented to by the insurer as required under Section 11.3.1.5 and authorized by public authorities having jurisdiction over the Project. Such partial occupancy or use may commence whether or not the portion is substantially complete, provided the Owner and Contractor have accepted in writing the responsibilities assigned to each of them for payments, retainage, if any, security, maintenance, heat, utilities, damage to the Work and insurance, and have agreed in writing concerning the period for correction of the Work and commencement of warranties required by the Contract Documents. When the Contractor considers a portion substantially complete, the Contractor shall prepare and submit a list to the Architect as provided under Section 9.8.2. Consent of the Contractor to partial occupancy or use shall not be unreasonably withheld. The stage of the progress of the Work shall be determined by written agreement between the Owner and Contractor or, if no agreement is reached, by decision of the Architect.

§ 9.9.2 Immediately prior to such partial occupancy or use, the Owner, Contractor and Architect shall jointly inspect the area to be occupied or portion of the Work to be used in order to determine and record the condition of the Work.

§ 9.9.3 Unless otherwise agreed upon, partial occupancy or use of a portion or portions of the Work shall not constitute acceptance of Work not complying with the requirements of the Contract Documents.



## § 9.10 FINAL COMPLETION AND FINAL PAYMENT

§ 9.10.1 Upon receipt of the Contractor's written notice that the Work is ready for final inspection and acceptance and upon receipt of a final Application for Payment, the Architect will promptly make such inspection and, when the Architect finds the Work acceptable under the Contract Documents and the Contract fully performed, the Architect will promptly issue a final Certificate for Payment stating that to the best of the Architect's knowledge, information and belief, and on the basis of the Architect's on-site visits and inspections, the Work has been completed in accordance with terms and conditions of the Contract Documents and that the entire balance found to be due the Contractor and noted in the final Certificate is due and payable. The Architect's final Certificate for Payment will constitute a further representation that conditions listed in Section 9.10.2 as precedent to the Contractor's being entitled to final payment have been fulfilled.

§ 9.10.2 Neither final payment nor any remaining retained percentage shall become due until the Contractor submits to the Architect (1) an affidavit that payrolls, bills for materials and equipment, and other indebtedness connected with the Work for which the Owner or the Owner's property might be responsible or encumbered (less amounts withheld by Owner) have been paid or otherwise satisfied, (2) a certificate evidencing that insurance required by the Contract Documents to remain in force after final payment is currently in effect and will not be canceled or allowed to expire until at least 30 days' prior written notice has been given to the Owner, (3) a written statement that the Contractor knows of no substantial reason that the insurance will not be renewable to cover the period required by the Contract Documents, (4) consent of surety, if any, to final payment and (5), if required by the Owner, other data establishing payment or satisfaction of obligations, such as receipts, releases and waivers of liens, claims, security interests or encumbrances arising out of the Contract, to the extent and in such form as may be designated by the Owner. If a Subcontractor refuses to furnish a release or waiver required by the Owner, the Contractor may furnish a bond satisfactory to the Owner to indemnify the Owner against such lien. If such lien remains unsatisfied after payments are made, the Contractor shall refund to the Owner all money that the Owner may be compelled to pay in discharging such lien, including all costs and reasonable attorneys' fees.

§ 9.10.3 If, after Substantial Completion of the Work, final completion thereof is materially delayed through no fault of the Contractor or by issuance of Change Orders affecting final completion, and the Architect so confirms, the Owner shall, upon application by the Contractor and certification by the Architect, and without terminating the Contract, make payment of the balance due for that portion of the Work fully completed and accepted. If the remaining balance for Work not fully completed or corrected is less than retainage stipulated in the Contract Documents, and if bonds have been furnished, the written consent of surety to payment of the balance due for that portion of the Work fully completed and accepted shall be submitted by the Contractor to the Architect prior to certification of such payment. Such payment shall be made under terms and conditions governing final payment, except that it shall not constitute a waiver of claims.

§ 9.10.4 The making of final payment shall constitute a waiver of Claims by the Owner except those arising from

- .1 liens, Claims, security interests or encumbrances arising out of the Contract and unsettled;
- .2 failure of the Work to comply with the requirements of the Contract Documents; or
- .3 terms of special warranties required by the Contract Documents.

§ 9.10.5 Acceptance of final payment by the Contractor, a Subcontractor or material supplier shall constitute a waiver of claims by that payee except those previously made in writing and identified by that payee as unsettled at the time of final Application for Payment.

## ARTICLE 10 PROTECTION OF PERSONS AND PROPERTY

### § 10.1 SAFETY PRECAUTIONS AND PROGRAMS

The Contractor shall be responsible for initiating, maintaining and supervising all safety precautions and programs in connection with the performance of the Contract.

### § 10.2 SAFETY OF PERSONS AND PROPERTY

§ 10.2.1 The Contractor shall take reasonable precautions for safety of, and shall provide reasonable protection to prevent damage, injury or loss to

- .1 employees on the Work and other persons who may be affected thereby;
- .2 the Work and materials and equipment to be incorporated therein, whether in storage on or off the site, under care, custody or control of the Contractor or the Contractor's Subcontractors or Sub-subcontractors; and

- 3 other property at the site or adjacent thereto, such as trees, shrubs, lawns, walks, pavements, roadways, structures and utilities not designated for removal, relocation or replacement in the course of construction.

§ 10.2.2 The Contractor shall comply with and give notices required by applicable laws, statutes, ordinances, codes, rules and regulations, and lawful orders of public authorities bearing on safety of persons or property or their protection from damage, injury or loss.

§ 10.2.3 The Contractor shall erect and maintain, as required by existing conditions and performance of the Contract, reasonable safeguards for safety and protection, including posting danger signs and other warnings against hazards, promulgating safety regulations and notifying owners and users of adjacent sites and utilities.

§ 10.2.4 When use or storage of explosives or other hazardous materials or equipment or unusual methods are necessary for execution of the Work, the Contractor shall exercise utmost care and carry on such activities under supervision of properly qualified personnel.

§ 10.2.5 The Contractor shall promptly remedy damage and loss (other than damage or loss insured under property insurance required by the Contract Documents) to property referred to in Sections 10.2.1.2 and 10.2.1.3 caused in whole or in part by the Contractor, a Subcontractor, a Sub-subcontractor, or anyone directly or indirectly employed by any of them, or by anyone for whose acts they may be liable and for which the Contractor is responsible under Sections 10.2.1.2 and 10.2.1.3, except damage or loss attributable to acts or omissions of the Owner or Architect or anyone directly or indirectly employed by either of them, or by anyone for whose acts either of them may be liable, and not attributable to the fault or negligence of the Contractor. The foregoing obligations of the Contractor are in addition to the Contractor's obligations under Section 3.18.

§ 10.2.6 The Contractor shall designate a responsible member of the Contractor's organization at the site whose duty shall be the prevention of accidents. This person shall be the Contractor's superintendent unless otherwise designated by the Contractor in writing to the Owner and Architect.

§ 10.2.7 The Contractor shall not permit any part of the construction or site to be loaded so as to cause damage or create an unsafe condition.

#### § 10.2.8 INJURY OR DAMAGE TO PERSON OR PROPERTY

If either party suffers injury or damage to person or property because of an act or omission of the other party, or of others for whose acts such party is legally responsible, written notice of such injury or damage, whether or not insured, shall be given to the other party within a reasonable time not exceeding 21 days after discovery. The notice shall provide sufficient detail to enable the other party to investigate the matter.

#### § 10.3 HAZARDOUS MATERIALS

§ 10.3.1 The Contractor is responsible for compliance with any requirements included in the Contract Documents regarding hazardous materials. If the Contractor encounters a hazardous material or substance not addressed in the Contract Documents and if reasonable precautions will be inadequate to prevent foreseeable bodily injury or death to persons resulting from a material or substance, including but not limited to asbestos or polychlorinated biphenyl (PCB), encountered on the site by the Contractor, the Contractor shall, upon recognizing the condition, immediately stop Work in the affected area and report the condition to the Owner and Architect in writing.

§ 10.3.2 Upon receipt of the Contractor's written notice, the Owner shall obtain the services of a licensed laboratory to verify the presence or absence of the material or substance reported by the Contractor and, in the event such material or substance is found to be present, to cause it to be rendered harmless. Unless otherwise required by the Contract Documents, the Owner shall furnish in writing to the Contractor and Architect the names and qualifications of persons or entities who are to perform tests verifying the presence or absence of such material or substance or who are to perform the task of removal or safe containment of such material or substance. The Contractor and the Architect will promptly reply to the Owner in writing stating whether or not either has reasonable objection to the persons or entities proposed by the Owner. If either the Contractor or Architect has an objection to a person or entity proposed by the Owner, the Owner shall propose another to whom the Contractor and the Architect have no reasonable objection. When the material or substance has been rendered harmless, Work in the affected area shall resume upon written agreement of the Owner and Contractor. By Change Order, the Contract Time shall be

Init.

extended appropriately and the Contract Sum shall be increased in the amount of the Contractor's reasonable additional costs of shut-down, delay and start-up.

§ 10.3.3 To the fullest extent permitted by law, the Owner shall indemnify and hold harmless the Contractor, Subcontractors, Architect, Architect's consultants and agents and employees of any of them from and against claims, damages, losses and expenses, including but not limited to attorneys' fees, arising out of or resulting from performance of the Work in the affected area if in fact the material or substance presents the risk of bodily injury or death as described in Section 10.3.1 and has not been rendered harmless, provided that such claim, damage, loss or expense is attributable to bodily injury, sickness, disease or death, or to injury to or destruction of tangible property (other than the Work itself), except to the extent that such damage, loss or expense is due to the fault or negligence of the party seeking indemnity.

§ 10.3.4 The Owner shall not be responsible under this Section 10.3 for materials or substances the Contractor brings to the site unless such materials or substances are required by the Contract Documents. The Owner shall be responsible for materials or substances required by the Contract Documents, except to the extent of the Contractor's fault or negligence in the use and handling of such materials or substances.

§ 10.3.5 The Contractor shall indemnify the Owner for the cost and expense the Owner incurs (1) for remediation of a material or substance the Contractor brings to the site and negligently handles, or (2) where the Contractor fails to perform its obligations under Section 10.3.1, except to the extent that the cost and expense are due to the Owner's fault or negligence.

§ 10.3.6 If, without negligence on the part of the Contractor, the Contractor is held liable by a government agency for the cost of remediation of a hazardous material or substance solely by reason of performing Work as required by the Contract Documents, the Owner shall indemnify the Contractor for all cost and expense thereby incurred.

#### § 10.4 EMERGENCIES

In an emergency affecting safety of persons or property, the Contractor shall act, at the Contractor's discretion, to prevent threatened damage, injury or loss. Additional compensation or extension of time claimed by the Contractor on account of an emergency shall be determined as provided in Article 15 and Article 7.

### ARTICLE 11 INSURANCE AND BONDS

#### § 11.1 CONTRACTOR'S LIABILITY INSURANCE

§ 11.1.1 The Contractor shall purchase from and maintain in a company or companies lawfully authorized to do business in the jurisdiction in which the Project is located such insurance as will protect the Contractor from claims set forth below which may arise out of or result from the Contractor's operations and completed operations under the Contract and for which the Contractor may be legally liable, whether such operations be by the Contractor or by a Subcontractor or by anyone directly or indirectly employed by any of them, or by anyone for whose acts any of them may be liable:

- .1 Claims under workers' compensation, disability benefit and other similar employee benefit acts that are applicable to the Work to be performed;
- .2 Claims for damages because of bodily injury, occupational sickness or disease, or death of the Contractor's employees;
- .3 Claims for damages because of bodily injury, sickness or disease, or death of any person other than the Contractor's employees;
- .4 Claims for damages insured by usual personal injury liability coverage;
- .5 Claims for damages, other than to the Work itself, because of injury to or destruction of tangible property, including loss of use resulting therefrom;
- .6 Claims for damages because of bodily injury, death of a person or property damage arising out of ownership, maintenance or use of a motor vehicle;
- .7 Claims for bodily injury or property damage arising out of completed operations; and
- .8 Claims involving contractual liability insurance applicable to the Contractor's obligations under Section 3.18.

§ 11.1.2 The insurance required by Section 11.1.1 shall be written for not less than limits of liability specified in the Contract Documents or required by law, whichever coverage is greater. Coverages, whether written on an occurrence or claims-made basis, shall be maintained without interruption from the date of commencement of the

Init.

Work until the date of final payment and termination of any coverage required to be maintained after final payment, and, with respect to the Contractor's completed operations coverage, until the expiration of the period for correction of Work or for such other period for maintenance of completed operations coverage as specified in the Contract Documents.

§ 11.1.3 Certificates of insurance acceptable to the Owner shall be filed with the Owner prior to commencement of the Work and thereafter upon renewal or replacement of each required policy of insurance. These certificates and the insurance policies required by this Section 11.1 shall contain a provision that coverages afforded under the policies will not be canceled or allowed to expire until at least 30 days' prior written notice has been given to the Owner. An additional certificate evidencing continuation of liability coverage, including coverage for completed operations, shall be submitted with the final Application for Payment as required by Section 9.10.2 and thereafter upon renewal or replacement of such coverage until the expiration of the time required by Section 11.1.2. Information concerning reduction of coverage on account of revised limits or claims paid under the General Aggregate, or both, shall be furnished by the Contractor with reasonable promptness.

§ 11.1.4 The Contractor shall cause the commercial liability coverage required by the Contract Documents to include (1) the Owner, the Architect and the Architect's consultants as additional insureds for claims caused in whole or in part by the Contractor's negligent acts or omissions during the Contractor's operations; and (2) the Owner as an additional insured for claims caused in whole or in part by the Contractor's negligent acts or omissions during the Contractor's completed operations.

#### § 11.2 OWNER'S LIABILITY INSURANCE

The Owner shall be responsible for purchasing and maintaining the Owner's usual liability insurance.

#### § 11.3 PROPERTY INSURANCE

§ 11.3.1 Unless otherwise provided, the Owner shall purchase and maintain, in a company or companies lawfully authorized to do business in the jurisdiction in which the Project is located, property insurance written on a builder's risk "all-risk" or equivalent policy form in the amount of the initial Contract Sum, plus value of subsequent Contract Modifications and cost of materials supplied or installed by others, comprising total value for the entire Project at the site on a replacement cost basis without optional deductibles. Such property insurance shall be maintained, unless otherwise provided in the Contract Documents or otherwise agreed in writing by all persons and entities who are beneficiaries of such insurance, until final payment has been made as provided in Section 9.10 or until no person or entity other than the Owner has an insurable interest in the property required by this Section 11.3 to be covered, whichever is later. This insurance shall include interests of the Owner, the Contractor, Subcontractors and Sub-subcontractors in the Project.

§ 11.3.1.1 Property insurance shall be on an "all-risk" or equivalent policy form and shall include, without limitation, insurance against the perils of fire (with extended coverage) and physical loss or damage including, without duplication of coverage, theft, vandalism, malicious mischief, collapse, earthquake, flood, windstorm, falsework, testing and startup, temporary buildings and debris removal including demolition occasioned by enforcement of any applicable legal requirements, and shall cover reasonable compensation for Architect's and Contractor's services and expenses required as a result of such insured loss.

§ 11.3.1.2 If the Owner does not intend to purchase such property insurance required by the Contract and with all of the coverages in the amount described above, the Owner shall so inform the Contractor in writing prior to commencement of the Work. The Contractor may then effect insurance that will protect the interests of the Contractor, Subcontractors and Sub-subcontractors in the Work, and by appropriate Change Order the cost thereof shall be charged to the Owner. If the Contractor is damaged by the failure or neglect of the Owner to purchase or maintain insurance as described above, without so notifying the Contractor in writing, then the Owner shall bear all reasonable costs properly attributable thereto.

§ 11.3.1.3 If the property insurance requires deductibles, the Owner shall pay costs not covered because of such deductibles.

§ 11.3.1.4 This property insurance shall cover portions of the Work stored off the site, and also portions of the Work in transit.

Init.



§ 11.3.1.5 Partial occupancy or use in accordance with Section 9.9 shall not commence until the insurance company or companies providing property insurance have consented to such partial occupancy or use by endorsement or otherwise. The Owner and the Contractor shall take reasonable steps to obtain consent of the insurance company or companies and shall, without mutual written consent, take no action with respect to partial occupancy or use that would cause cancellation, lapse or reduction of insurance.

#### § 11.3.2 BOILER AND MACHINERY INSURANCE

The Owner shall purchase and maintain boiler and machinery insurance required by the Contract Documents or by law, which shall specifically cover such insured objects during installation and until final acceptance by the Owner; this insurance shall include interests of the Owner, Contractor, Subcontractors and Sub-subcontractors in the Work, and the Owner and Contractor shall be named insureds.

#### § 11.3.3 LOSS OF USE INSURANCE

The Owner, at the Owner's option, may purchase and maintain such insurance as will insure the Owner against loss of use of the Owner's property due to fire or other hazards, however caused. The Owner waives all rights of action against the Contractor for loss of use of the Owner's property, including consequential losses due to fire or other hazards however caused.

§ 11.3.4 If the Contractor requests in writing that insurance for risks other than those described herein or other special causes of loss be included in the property insurance policy, the Owner shall, if possible, include such insurance, and the cost thereof shall be charged to the Contractor by appropriate Change Order.

§ 11.3.5 If during the Project construction period the Owner insures properties, real or personal or both, at or adjacent to the site by property insurance under policies separate from those insuring the Project, or if after final payment property insurance is to be provided on the completed Project through a policy or policies other than those insuring the Project during the construction period, the Owner shall waive all rights in accordance with the terms of Section 11.3.7 for damages caused by fire or other causes of loss covered by this separate property insurance. All separate policies shall provide this waiver of subrogation by endorsement or otherwise.

§ 11.3.6 Before an exposure to loss may occur, the Owner shall file with the Contractor a copy of each policy that includes insurance coverages required by this Section 11.3. Each policy shall contain all generally applicable conditions, definitions, exclusions and endorsements related to this Project. Each policy shall contain a provision that the policy will not be canceled or allowed to expire, and that its limits will not be reduced, until at least 30 days' prior written notice has been given to the Contractor.

#### § 11.3.7 WAIVERS OF SUBROGATION

The Owner and Contractor waive all rights against (1) each other and any of their subcontractors, sub-subcontractors, agents and employees, each of the other, and (2) the Architect, Architect's consultants, separate contractors described in Article 6, if any, and any of their subcontractors, sub-subcontractors, agents and employees, for damages caused by fire or other causes of loss to the extent covered by property insurance obtained pursuant to this Section 11.3 or other property insurance applicable to the Work, except such rights as they have to proceeds of such insurance held by the Owner as fiduciary. The Owner or Contractor, as appropriate, shall require of the Architect, Architect's consultants, separate contractors described in Article 6, if any, and the subcontractors, sub-subcontractors, agents and employees of any of them, by appropriate agreements, written where legally required for validity, similar waivers each in favor of other parties enumerated herein. The policies shall provide such waivers of subrogation by endorsement or otherwise. A waiver of subrogation shall be effective as to a person or entity even though that person or entity would otherwise have a duty of indemnification, contractual or otherwise, did not pay the insurance premium directly or indirectly, and whether or not the person or entity had an insurable interest in the property damaged.

§ 11.3.8 A loss insured under the Owner's property insurance shall be adjusted by the Owner as fiduciary and made payable to the Owner as fiduciary for the insureds, as their interests may appear, subject to requirements of any applicable mortgagee clause and of Section 11.3.10. The Contractor shall pay Subcontractors their just shares of insurance proceeds received by the Contractor, and by appropriate agreements, written where legally required for validity, shall require Subcontractors to make payments to their Sub-subcontractors in similar manner.

§ 11.3.9 If required in writing by a party in interest, the Owner as fiduciary shall, upon occurrence of an insured loss, give bond for proper performance of the Owner's duties. The cost of required bonds shall be charged against proceeds received as fiduciary. The Owner shall deposit in a separate account proceeds so received, which the Owner shall distribute in accordance with such agreement as the parties in interest may reach, or as determined in accordance with the method of binding dispute resolution selected in the Agreement between the Owner and Contractor. If after such loss no other special agreement is made and unless the Owner terminates the Contract for convenience, replacement of damaged property shall be performed by the Contractor after notification of a Change in the Work in accordance with Article 7.

§ 11.3.10 The Owner as fiduciary shall have power to adjust and settle a loss with insurers unless one of the parties in interest shall object in writing within five days after occurrence of loss to the Owner's exercise of this power; if such objection is made, the dispute shall be resolved in the manner selected by the Owner and Contractor as the method of binding dispute resolution in the Agreement. If the Owner and Contractor have selected arbitration as the method of binding dispute resolution, the Owner as fiduciary shall make settlement with insurers or, in the case of a dispute over distribution of insurance proceeds, in accordance with the directions of the arbitrators.

#### § 11.4 PERFORMANCE BOND AND PAYMENT BOND

§ 11.4.1 The Owner shall have the right to require the Contractor to furnish bonds covering faithful performance of the Contract and payment of obligations arising thereunder as stipulated in bidding requirements or specifically required in the Contract Documents on the date of execution of the Contract.

§ 11.4.2 Upon the request of any person or entity appearing to be a potential beneficiary of bonds covering payment of obligations arising under the Contract, the Contractor shall promptly furnish a copy of the bonds or shall authorize a copy to be furnished.

### ARTICLE 12 UNCOVERING AND CORRECTION OF WORK

#### § 12.1 UNCOVERING OF WORK

§ 12.1.1 If a portion of the Work is covered contrary to the Architect's request or to requirements specifically expressed in the Contract Documents, it must, if requested in writing by the Architect, be uncovered for the Architect's examination and be replaced at the Contractor's expense without change in the Contract Time.

§ 12.1.2 If a portion of the Work has been covered that the Architect has not specifically requested to examine prior to its being covered, the Architect may request to see such Work and it shall be uncovered by the Contractor. If such Work is in accordance with the Contract Documents, costs of uncovering and replacement shall, by appropriate Change Order, be at the Owner's expense. If such Work is not in accordance with the Contract Documents, such costs and the cost of correction shall be at the Contractor's expense unless the condition was caused by the Owner or a separate contractor in which event the Owner shall be responsible for payment of such costs.

#### § 12.2 CORRECTION OF WORK

##### § 12.2.1 BEFORE OR AFTER SUBSTANTIAL COMPLETION

The Contractor shall promptly correct Work rejected by the Architect or failing to conform to the requirements of the Contract Documents, whether discovered before or after Substantial Completion and whether or not fabricated, installed or completed. Costs of correcting such rejected Work, including additional testing and inspections, the cost of uncovering and replacement, and compensation for the Architect's services and expenses made necessary thereby, shall be at the Contractor's expense.

##### § 12.2.2 AFTER SUBSTANTIAL COMPLETION

§ 12.2.2.1 In addition to the Contractor's obligations under Section 3.5, if, within one year after the date of Substantial Completion of the Work or designated portion thereof or after the date for commencement of warranties established under Section 9.9.1, or by terms of an applicable special warranty required by the Contract Documents, any of the Work is found to be not in accordance with the requirements of the Contract Documents, the Contractor shall correct it promptly after receipt of written notice from the Owner to do so unless the Owner has previously given the Contractor a written acceptance of such condition. The Owner shall give such notice promptly after discovery of the condition. During the one-year period for correction of Work, if the Owner fails to notify the Contractor and give the Contractor an opportunity to make the correction, the Owner waives the rights to require correction by the Contractor and to make a claim for breach of warranty. If the Contractor fails to correct

Init.

nonconforming Work within a reasonable time during that period after receipt of notice from the Owner or Architect, the Owner may correct it in accordance with Section 2.4.

§ 12.2.2.2 The one-year period for correction of Work shall be extended with respect to portions of Work first performed after Substantial Completion by the period of time between Substantial Completion and the actual completion of that portion of the Work.

§ 12.2.2.3 The one-year period for correction of Work shall not be extended by corrective Work performed by the Contractor pursuant to this Section 12.2.

§ 12.2.3 The Contractor shall remove from the site portions of the Work that are not in accordance with the requirements of the Contract Documents and are neither corrected by the Contractor nor accepted by the Owner.

§ 12.2.4 The Contractor shall bear the cost of correcting destroyed or damaged construction, whether completed or partially completed, of the Owner or separate contractors caused by the Contractor's correction or removal of Work that is not in accordance with the requirements of the Contract Documents.

§ 12.2.5 Nothing contained in this Section 12.2 shall be construed to establish a period of limitation with respect to other obligations the Contractor has under the Contract Documents. Establishment of the one-year period for correction of Work as described in Section 12.2.2 relates only to the specific obligation of the Contractor to correct the Work, and has no relationship to the time within which the obligation to comply with the Contract Documents may be sought to be enforced, nor to the time within which proceedings may be commenced to establish the Contractor's liability with respect to the Contractor's obligations other than specifically to correct the Work.

### § 12.3 ACCEPTANCE OF NONCONFORMING WORK

If the Owner prefers to accept Work that is not in accordance with the requirements of the Contract Documents, the Owner may do so instead of requiring its removal and correction, in which case the Contract Sum will be reduced as appropriate and equitable. Such adjustment shall be effected whether or not final payment has been made.

## ARTICLE 13 MISCELLANEOUS PROVISIONS

### § 13.1 GOVERNING LAW

The Contract shall be governed by the law of the place where the Project is located except that, if the parties have selected arbitration as the method of binding dispute resolution, the Federal Arbitration Act shall govern Section 15.4.

### § 13.2 SUCCESSORS AND ASSIGNS

§ 13.2.1 The Owner and Contractor respectively bind themselves, their partners, successors, assigns and legal representatives to covenants, agreements and obligations contained in the Contract Documents. Except as provided in Section 13.2.2, neither party to the Contract shall assign the Contract as a whole without written consent of the other. If either party attempts to make such an assignment without such consent, that party shall nevertheless remain legally responsible for all obligations under the Contract.

§ 13.2.2 The Owner may, without consent of the Contractor, assign the Contract to a lender providing construction financing for the Project, if the lender assumes the Owner's rights and obligations under the Contract Documents. The Contractor shall execute all consents reasonably required to facilitate such assignment.

### § 13.3 WRITTEN NOTICE

Written notice shall be deemed to have been duly served if delivered in person to the individual, to a member of the firm or entity, or to an officer of the corporation for which it was intended; or if delivered at, or sent by registered or certified mail or by courier service providing proof of delivery to, the last business address known to the party giving notice.

### § 13.4 RIGHTS AND REMEDIES

§ 13.4.1 Duties and obligations imposed by the Contract Documents and rights and remedies available thereunder shall be in addition to and not a limitation of duties, obligations, rights and remedies otherwise imposed or available by law.

Init.

§ 13.4.2 No action or failure to act by the Owner, Architect or Contractor shall constitute a waiver of a right or duty afforded them under the Contract, nor shall such action or failure to act constitute approval of or acquiescence in a breach there under, except as may be specifically agreed in writing.

### § 13.5 TESTS AND INSPECTIONS

§ 13.5.1 Tests, inspections and approvals of portions of the Work shall be made as required by the Contract Documents and by applicable laws, statutes, ordinances, codes, rules and regulations or lawful orders of public authorities. Unless otherwise provided, the Contractor shall make arrangements for such tests, inspections and approvals with an independent testing laboratory or entity acceptable to the Owner, or with the appropriate public authority, and shall bear all related costs of tests, inspections and approvals. The Contractor shall give the Architect timely notice of when and where tests and inspections are to be made so that the Architect may be present for such procedures. The Owner shall bear costs of (1) tests, inspections or approvals that do not become requirements until after bids are received or negotiations concluded, and (2) tests, inspections or approvals where building codes or applicable laws or regulations prohibit the Owner from delegating their cost to the Contractor.

§ 13.5.2 If the Architect, Owner or public authorities having jurisdiction determine that portions of the Work require additional testing, inspection or approval not included under Section 13.5.1, the Architect will, upon written authorization from the Owner, instruct the Contractor to make arrangements for such additional testing, inspection or approval by an entity acceptable to the Owner, and the Contractor shall give timely notice to the Architect of when and where tests and inspections are to be made so that the Architect may be present for such procedures. Such costs, except as provided in Section 13.5.3, shall be at the Owner's expense.

§ 13.5.3 If such procedures for testing, inspection or approval under Sections 13.5.1 and 13.5.2 reveal failure of the portions of the Work to comply with requirements established by the Contract Documents, all costs made necessary by such failure including those of repeated procedures and compensation for the Architect's services and expenses shall be at the Contractor's expense.

§ 13.5.4 Required certificates of testing, inspection or approval shall, unless otherwise required by the Contract Documents, be secured by the Contractor and promptly delivered to the Architect.

§ 13.5.5 If the Architect is to observe tests, inspections or approvals required by the Contract Documents, the Architect will do so promptly and, where practicable, at the normal place of testing.

§ 13.5.6 Tests or inspections conducted pursuant to the Contract Documents shall be made promptly to avoid unreasonable delay in the Work.

### § 13.6 INTEREST

Payments due and unpaid under the Contract Documents shall bear interest from the date payment is due at such rate as the parties may agree upon in writing or, in the absence thereof, at the legal rate prevailing from time to time at the place where the Project is located.

### § 13.7 TIME LIMITS ON CLAIMS

The Owner and Contractor shall commence all claims and causes of action, whether in contract, tort, breach of warranty or otherwise, against the other arising out of or related to the Contract in accordance with the requirements of the final dispute resolution method selected in the Agreement within the time period specified by applicable law, but in any case not more than 10 years after the date of Substantial Completion of the Work. The Owner and Contractor waive all claims and causes of action not commenced in accordance with this Section 13.7.

## ARTICLE 14 TERMINATION OR SUSPENSION OF THE CONTRACT

### § 14.1 TERMINATION BY THE CONTRACTOR

§ 14.1.1 The Contractor may terminate the Contract if the Work is stopped for a period of 30 consecutive days through no act or fault of the Contractor or a Subcontractor, Sub-subcontractor or their agents or employees or any other persons or entities performing portions of the Work under direct or indirect contract with the Contractor, for any of the following reasons:

- .1 Issuance of an order of a court or other public authority having jurisdiction that requires all Work to be stopped;

Init.



- .2 An act of government, such as a declaration of national emergency that requires all Work to be stopped;
- .3 Because the Architect has not issued a Certificate for Payment and has not notified the Contractor of the reason for withholding certification as provided in Section 9.4.1, or because the Owner has not made payment on a Certificate for Payment within the time stated in the Contract Documents; or
- .4 The Owner has failed to furnish to the Contractor promptly, upon the Contractor's request, reasonable evidence as required by Section 2.2.1.

§ 14.1.2 The Contractor may terminate the Contract if, through no act or fault of the Contractor or a Subcontractor, Sub-subcontractor or their agents or employees or any other persons or entities performing portions of the Work under direct or indirect contract with the Contractor, repeated suspensions, delays or interruptions of the entire Work by the Owner as described in Section 14.3 constitute in the aggregate more than 100 percent of the total number of days scheduled for completion, or 120 days in any 365-day period, whichever is less.

§ 14.1.3 If one of the reasons described in Section 14.1.1 or 14.1.2 exists, the Contractor may, upon seven days' written notice to the Owner and Architect, terminate the Contract and recover from the Owner payment for Work executed, including reasonable overhead and profit, costs incurred by reason of such termination, and damages.

§ 14.1.4 If the Work is stopped for a period of 60 consecutive days through no act or fault of the Contractor or a Subcontractor or their agents or employees or any other persons performing portions of the Work under contract with the Contractor because the Owner has repeatedly failed to fulfill the Owner's obligations under the Contract Documents with respect to matters important to the progress of the Work, the Contractor may, upon seven additional days' written notice to the Owner and the Architect, terminate the Contract and recover from the Owner as provided in Section 14.1.3.

#### § 14.2 TERMINATION BY THE OWNER FOR CAUSE

§ 14.2.1 The Owner may terminate the Contract if the Contractor

- .1 repeatedly refuses or fails to supply enough properly skilled workers or proper materials;
- .2 fails to make payment to Subcontractors for materials or labor in accordance with the respective agreements between the Contractor and the Subcontractors;
- .3 repeatedly disregards applicable laws, statutes, ordinances, codes, rules and regulations, or lawful orders of a public authority; or
- .4 otherwise is guilty of substantial breach of a provision of the Contract Documents.

§ 14.2.2 When any of the above reasons exist, the Owner, upon certification by the Initial Decision Maker that sufficient cause exists to justify such action, may without prejudice to any other rights or remedies of the Owner and after giving the Contractor and the Contractor's surety, if any, seven days' written notice, terminate employment of the Contractor and may, subject to any prior rights of the surety:

- .1 Exclude the Contractor from the site and take possession of all materials, equipment, tools, and construction equipment and machinery thereon owned by the Contractor;
- .2 Accept assignment of subcontracts pursuant to Section 5.4; and
- .3 Finish the Work by whatever reasonable method the Owner may deem expedient. Upon written request of the Contractor, the Owner shall furnish to the Contractor a detailed accounting of the costs incurred by the Owner in finishing the Work.

§ 14.2.3 When the Owner terminates the Contract for one of the reasons stated in Section 14.2.1, the Contractor shall not be entitled to receive further payment until the Work is finished.

§ 14.2.4 If the unpaid balance of the Contract Sum exceeds costs of finishing the Work, including compensation for the Architect's services and expenses made necessary thereby, and other damages incurred by the Owner and not expressly waived, such excess shall be paid to the Contractor. If such costs and damages exceed the unpaid balance, the Contractor shall pay the difference to the Owner. The amount to be paid to the Contractor or Owner, as the case may be, shall be certified by the Initial Decision Maker, upon application, and this obligation for payment shall survive termination of the Contract.

**§ 14.3 SUSPENSION BY THE OWNER FOR CONVENIENCE**

**§ 14.3.1** The Owner may, without cause, order the Contractor in writing to suspend, delay or interrupt the Work in whole or in part for such period of time as the Owner may determine.

**§ 14.3.2** The Contract Sum and Contract Time shall be adjusted for increases in the cost and time caused by suspension, delay or interruption as described in Section 14.3.1. Adjustment of the Contract Sum shall include profit. No adjustment shall be made to the extent

- .1 that performance is, was or would have been so suspended, delayed or interrupted by another cause for which the Contractor is responsible; or
- .2 that an equitable adjustment is made or denied under another provision of the Contract.

**§ 14.4 TERMINATION BY THE OWNER FOR CONVENIENCE**

**§ 14.4.1** The Owner may, at any time, terminate the Contract for the Owner's convenience and without cause.

**§ 14.4.2** Upon receipt of written notice from the Owner of such termination for the Owner's convenience, the Contractor shall

- .1 cease operations as directed by the Owner in the notice;
- .2 take actions necessary, or that the Owner may direct, for the protection and preservation of the Work; and
- .3 except for Work directed to be performed prior to the effective date of termination stated in the notice, terminate all existing subcontracts and purchase orders and enter into no further subcontracts and purchase orders.

**§ 14.4.3** In case of such termination for the Owner's convenience, the Contractor shall be entitled to receive payment for Work executed, and costs incurred by reason of such termination, along with reasonable overhead and profit on the Work not executed.

**ARTICLE 15 CLAIMS AND DISPUTES****§ 15.1 CLAIMS****§ 15.1.1 DEFINITION**

A Claim is a demand or assertion by one of the parties seeking, as a matter of right, payment of money, or other relief with respect to the terms of the Contract. The term "Claim" also includes other disputes and matters in question between the Owner and Contractor arising out of or relating to the Contract. The responsibility to substantiate Claims shall rest with the party making the Claim.

**§ 15.1.2 NOTICE OF CLAIMS**

Claims by either the Owner or Contractor must be initiated by written notice to the other party and to the Initial Decision Maker with a copy sent to the Architect, if the Architect is not serving as the Initial Decision Maker. Claims by either party must be initiated within 21 days after occurrence of the event giving rise to such Claim or within 21 days after the claimant first recognizes the condition giving rise to the Claim, whichever is later.

**§ 15.1.3 CONTINUING CONTRACT PERFORMANCE**

Pending final resolution of a Claim, except as otherwise agreed in writing or as provided in Section 9.7 and Article 14, the Contractor shall proceed diligently with performance of the Contract and the Owner shall continue to make payments in accordance with the Contract Documents. The Architect will prepare Change Orders and issue Certificates for Payment in accordance with the decisions of the Initial Decision Maker.

**§ 15.1.4 CLAIMS FOR ADDITIONAL COST**

If the Contractor wishes to make a Claim for an increase in the Contract Sum, written notice as provided herein shall be given before proceeding to execute the Work. Prior notice is not required for Claims relating to an emergency endangering life or property arising under Section 10.4.

**§ 15.1.5 CLAIMS FOR ADDITIONAL TIME**

**§ 15.1.5.1** If the Contractor wishes to make a Claim for an increase in the Contract Time, written notice as provided herein shall be given. The Contractor's Claim shall include an estimate of cost and of probable effect of delay on progress of the Work. In the case of a continuing delay, only one Claim is necessary.

Init.

§ 15.1.5.2 If adverse weather conditions are the basis for a Claim for additional time, such Claim shall be documented by data substantiating that weather conditions were abnormal for the period of time, could not have been reasonably anticipated and had an adverse effect on the scheduled construction.

#### § 15.1.6 CLAIMS FOR CONSEQUENTIAL DAMAGES

The Contractor and Owner waive Claims against each other for consequential damages arising out of or relating to this Contract. This mutual waiver includes

- .1 damages incurred by the Owner for rental expenses, for losses of use, income, profit, financing, business and reputation, and for loss of management or employee productivity or of the services of such persons; and
- .2 damages incurred by the Contractor for principal office expenses including the compensation of personnel stationed there, for losses of financing, business and reputation, and for loss of profit except anticipated profit arising directly from the Work.

This mutual waiver is applicable, without limitation, to all consequential damages due to either party's termination in accordance with Article 14. Nothing contained in this Section 15.1.6 shall be deemed to preclude an award of liquidated damages, when applicable, in accordance with the requirements of the Contract Documents.

#### § 15.2 INITIAL DECISION

§ 15.2.1 Claims, excluding those arising under Sections 10.3, 10.4, 11.3.9, and 11.3.10, shall be referred to the Initial Decision Maker for initial decision. The Architect will serve as the Initial Decision Maker, unless otherwise indicated in the Agreement. Except for those Claims excluded by this Section 15.2.1, an initial decision shall be required as a condition precedent to mediation of any Claim arising prior to the date final payment is due, unless 30 days have passed after the Claim has been referred to the Initial Decision Maker with no decision having been rendered. Unless the Initial Decision Maker and all affected parties agree, the Initial Decision Maker will not decide disputes between the Contractor and persons or entities other than the Owner.

§ 15.2.2 The Initial Decision Maker will review Claims and within ten days of the receipt of a Claim take one or more of the following actions: (1) request additional supporting data from the claimant or a response with supporting data from the other party, (2) reject the Claim in whole or in part, (3) approve the Claim, (4) suggest a compromise, or (5) advise the parties that the Initial Decision Maker is unable to resolve the Claim if the Initial Decision Maker lacks sufficient information to evaluate the merits of the Claim or if the Initial Decision Maker concludes that, in the Initial Decision Maker's sole discretion, it would be inappropriate for the Initial Decision Maker to resolve the Claim.

§ 15.2.3 In evaluating Claims, the Initial Decision Maker may, but shall not be obligated to, consult with or seek information from either party or from persons with special knowledge or expertise who may assist the Initial Decision Maker in rendering a decision. The Initial Decision Maker may request the Owner to authorize retention of such persons at the Owner's expense.

§ 15.2.4 If the Initial Decision Maker requests a party to provide a response to a Claim or to furnish additional supporting data, such party shall respond, within ten days after receipt of such request, and shall either (1) provide a response on the requested supporting data, (2) advise the Initial Decision Maker when the response or supporting data will be furnished or (3) advise the Initial Decision Maker that no supporting data will be furnished. Upon receipt of the response or supporting data, if any, the Initial Decision Maker will either reject or approve the Claim in whole or in part.

§ 15.2.5 The Initial Decision Maker will render an initial decision approving or rejecting the Claim, or indicating that the Initial Decision Maker is unable to resolve the Claim. This initial decision shall (1) be in writing; (2) state the reasons therefor; and (3) notify the parties and the Architect, if the Architect is not serving as the Initial Decision Maker, of any change in the Contract Sum or Contract Time or both. The initial decision shall be final and binding on the parties but subject to mediation and, if the parties fail to resolve their dispute through mediation, to binding dispute resolution.

§ 15.2.6 Either party may file for mediation of an initial decision at any time, subject to the terms of Section 15.2.6.1.

Init.

§ 15.2.6.1 Either party may, within 30 days from the date of an initial decision, demand in writing that the other party file for mediation within 60 days of the initial decision. If such a demand is made and the party receiving the demand fails to file for mediation within the time required, then both parties waive their rights to mediate or pursue binding dispute resolution proceedings with respect to the initial decision.

§ 15.2.7 In the event of a Claim against the Contractor, the Owner may, but is not obligated to, notify the surety, if any, of the nature and amount of the Claim. If the Claim relates to a possibility of a Contractor's default, the Owner may, but is not obligated to, notify the surety and request the surety's assistance in resolving the controversy.

§ 15.2.8 If a Claim relates to or is the subject of a mechanic's lien, the party asserting such Claim may proceed in accordance with applicable law to comply with the lien notice or filing deadlines.

### § 15.3 MEDIATION

§ 15.3.1 Claims, disputes, or other matters in controversy arising out of or related to the Contract except those waived as provided for in Sections 9.10.4, 9.10.5, and 15.1.6 shall be subject to mediation as a condition precedent to binding dispute resolution.

§ 15.3.2 The parties shall endeavor to resolve their Claims by mediation which, unless the parties mutually agree otherwise, shall be administered by the American Arbitration Association in accordance with its Construction Industry Mediation Procedures in effect on the date of the Agreement. A request for mediation shall be made in writing, delivered to the other party to the Contract, and filed with the person or entity administering the mediation. The request may be made concurrently with the filing of binding dispute resolution proceedings but, in such event, mediation shall proceed in advance of binding dispute resolution proceedings, which shall be stayed pending mediation for a period of 60 days from the date of filing, unless stayed for a longer period by agreement of the parties or court order. If an arbitration is stayed pursuant to this Section 15.3.2, the parties may nonetheless proceed to the selection of the arbitrator(s) and agree upon a schedule for later proceedings.

§ 15.3.3 The parties shall share the mediator's fee and any filing fees equally. The mediation shall be held in the place where the Project is located, unless another location is mutually agreed upon. Agreements reached in mediation shall be enforceable as settlement agreements in any court having jurisdiction thereof.

### § 15.4 ARBITRATION

§ 15.4.1 If the parties have selected arbitration as the method for binding dispute resolution in the Agreement, any Claim subject to, but not resolved by, mediation shall be subject to arbitration which, unless the parties mutually agree otherwise, shall be administered by the American Arbitration Association in accordance with its Construction Industry Arbitration Rules in effect on the date of the Agreement. A demand for arbitration shall be made in writing, delivered to the other party to the Contract, and filed with the person or entity administering the arbitration. The party filing a notice of demand for arbitration must assert in the demand all Claims then known to that party on which arbitration is permitted to be demanded.

§ 15.4.1.1 A demand for arbitration shall be made no earlier than concurrently with the filing of a request for mediation, but in no event shall it be made after the date when the institution of legal or equitable proceedings based on the Claim would be barred by the applicable statute of limitations. For statute of limitations purposes, receipt of a written demand for arbitration by the person or entity administering the arbitration shall constitute the institution of legal or equitable proceedings based on the Claim.

§ 15.4.2 The award rendered by the arbitrator or arbitrators shall be final, and judgment may be entered upon it in accordance with applicable law in any court having jurisdiction thereof.

§ 15.4.3 The foregoing agreement to arbitrate and other agreements to arbitrate with an additional person or entity duly consented to by parties to the Agreement shall be specifically enforceable under applicable law in any court having jurisdiction thereof.

### § 15.4.4 CONSOLIDATION OR JOINDER

§ 15.4.4.1 Either party, at its sole discretion, may consolidate an arbitration conducted under this Agreement with any other arbitration to which it is a party provided that (1) the arbitration agreement governing the other arbitration

permits consolidation, (2) the arbitrations to be consolidated substantially involve common questions of law or fact, and (3) the arbitrations employ materially similar procedural rules and methods for selecting arbitrator(s).

§ 15.4.4.2 Either party, at its sole discretion, may include by joinder persons or entities substantially involved in a common question of law or fact whose presence is required if complete relief is to be accorded in arbitration, provided that the party sought to be joined consents in writing to such joinder. Consent to arbitration involving an additional person or entity shall not constitute consent to arbitration of any claim, dispute or other matter in question not described in the written consent.

§ 15.4.4.3 The Owner and Contractor grant to any person or entity made a party to an arbitration conducted under this Section 15.4, whether by joinder or consolidation, the same rights of joinder and consolidation as the Owner and Contractor under this Agreement.